



RAISING CANE'S TRAFFIC STUDY
Costa Mesa, California

October 30, 2023

Prepared for:
City of Costa Mesa

Prepared by:
Stantec Consulting Services Inc.

Project Number:
2042657200

The conclusions in the Report titled Raising Cane's Traffic Study are Stantec's professional opinion, as of the time of the Report, and concerning the scope described in the Report. The opinions in the document are based on conditions and information existing at the time the scope of work was conducted and do not take into account any subsequent changes. The Report relates solely to the specific project for which Stantec was retained and the stated purpose for which the Report was prepared. The Report is not to be used or relied on for any variation or extension of the project, or for any other project or purpose, and any unauthorized use or reliance is at the recipient's own risk.

Stantec has assumed all information received from City of Costa Mesa (the "Client") and third parties in the preparation of the Report to be correct. While Stantec has exercised a customary level of judgment or due diligence in the use of such information, Stantec assumes no responsibility for the consequences of any error or omission contained therein.

This Report is intended solely for use by the Client in accordance with Stantec's contract with the Client. While the Report may be provided by the Client to applicable authorities having jurisdiction and to other third parties in connection with the project, Stantec disclaims any legal duty based upon warranty, reliance or any other theory to any third party, and will not be liable to such third party for any damages or losses of any kind that may result.

Prepared by:  _____
Signature

Trip Generation Case Study
Cathy Lawrence, TE
Transportation Engineer

Prepared by:  _____
Signature

Traffic Analysis & Final Report
Sandhya Perumalla, ENV SP
Senior Transportation Planner

Reviewed by:  _____
Signature

Daryl Zerfass, PE, PTP
Principal, Transportation Planning and Traffic
Engineering

Table of Contents

1	INTRODUCTION.....	1
1.1	Project Description	1
1.2	Approach.....	1
1.3	Project Analysis Methodology	4
2	TRAFFIC ANALYSIS.....	5
2.1	Trip Generation Case Study.....	5
2.2	Study Area	8
2.3	Project Trip Distribution	9
2.4	Opening Year (2024) Cumulative Conditions Analysis.....	21
2.5	Site Access and Circulation Analysis	28
3	PARKING ANALYSIS.....	30
4	DRIVE-THROUGH QUEUE ANALYSIS.....	31
5	CONCLUSION.....	35

LIST OF TABLES

Table 1	Intersection Level of Service Ranges (HCM Delay)	4
Table 2	Intersection Performance Criteria	5
Table 3	Trip Generation Summary based on ITE & Case Study Trip Rates – Weekday.....	6
Table 4	Trip Generation Summary based on ITE & Case Study Trip Rates – Saturday.....	6
Table 5	Trip Generation Summary based on Case Studies of Local Raising Cane’s – Weekday	7
Table 6	Trip Generation Summary based on Case Studies of Local Raising Cane’s – Saturday	8
Table 7	Intersection LOS Summary – Existing Conditions	9
Table 8	Intersection LOS Summary – Opening Year (2024) Cumulative Conditions	21
Table 9	Site Access Driveway LOS Summary – Opening Year (2024) Cumulative Conditions with Project.....	28
Table 10	Case Studies Parking Summary	30
Table 11	Required Parking Summary using Case Studies Parking Rate.....	31
Table 12	Case Studies Drive-Through Queue Summary	31
Table 13	Case Study Drive-Through Queue Summary – Costa Mesa Location	32

LIST OF FIGURES

Figure 1	Project Location Map and Study Area Intersections.....	2
Figure 2	Project Site Plan	3
Figure 3	Existing Intersection Lane Geometry.....	10
Figure 4	Existing Mid-day Peak Hour Volumes – Weekday	11
Figure 5	Existing PM Peak Hour Volumes – Weekday	12
Figure 6	Existing Mid-Day Peak Hour Volumes – Saturday	13
Figure 7	Project Trip Distribution.....	14
Figure 8	Net Project Trips – Mid-Day Peak Hour – Weekday.....	15
Figure 9	Net Project Trips – PM Peak Hour – Weekday	16
Figure 10	Net Project Trips – Mid-Day Peak Hour – Saturday	17
Figure 11	Pass-By Project Trips – Mid-Day Peak Hour – Weekday	18
Figure 12	Pass-By Project Trips – PM Peak Hour – Weekday.....	19
Figure 13	Pass-By Project Trips – Mid-Day Peak Hour – Saturday.....	20
Figure 14	Opening Year (2024) Cumulative Conditions No Project - Mid-Day Peak Hour Volumes – Weekday	22
Figure 15	Opening Year (2024) Cumulative Conditions No Project - PM Peak Hour Volumes - Weekday	23



Figure 16 Opening Year (2024) Cumulative Conditions No Project - Mid-Day Peak Hour Volumes – Saturday.....	24
Figure 17 Opening Year (2024) Cumulative Conditions with-Project - Mid-Day Peak Hour Volumes – Weekday.....	25
Figure 18 Opening Year (2024) Cumulative Conditions with-Project - PM Peak Hour Volumes - Weekday.....	26
Figure 19 Opening Year (2024) Cumulative Conditions with-Project - Mid-Day Peak Hour Volumes – Saturday.....	27
Figure 20 Project Driveway Peak Hour Volumes and Lane Configurations	29
Figure 21 Weekday Mid-Day Queue Data at the Raising Cane’s Case Study Locations	33
Figure 22 Weekday PM Queue Data at the Raising Cane’s Case Study Locations.....	33
Figure 23 Weekend Mid-Day Queue Data at the Raising Cane’s Case Study Locations.....	34
Figure 24 Weekend PM Queue Data at the Raising Cane’s Case Study Locations.....	34

LIST OF APPENDICES

APPENDIX A	DRIVEWAY ENTER AND EXIT TRAFFIC VOLUME DATA SHEETS.....	A.1
APPENDIX B	TRAFFIC COUNT DATA SHEETS	B.1
APPENDIX C	LOS WORKSHEETS	C.1
APPENDIX D	PARKING AND QUEUING SURVEY DATA SHEETS	D.1



1 Introduction

Stantec Consulting Services Inc. (Stantec) has prepared a traffic analysis for a proposed Raising Cane's restaurant (Project) in the City of Costa Mesa, California. The Project consists of a fast-food restaurant with a drive-through on a site previously occupied by commercial retail uses. The purpose of this report is to document the data and findings of the traffic analysis, which includes traffic operational analysis, parking analysis and drive-through queue analysis.

1.1 Project Description

The Project site is located at 1595 Newport Boulevard, just south of East 16th Street. The proposed Raising Cane's building gross square footage is approximately 3,000 square feet. Primary access to the Project site is via the Old Newport Boulevard frontage road, on the west side of Newport Boulevard. See Figure 1 for the Project Location Map. The proposed Project would replace an existing 25,159 square-foot commercial retail building (currently unoccupied furniture store) with a stand-alone fast-food restaurant with a drive-through. See Figure 2 for the Project Site Plan.

1.2 Approach

This traffic study includes a trip generation analysis, a parking analysis, and a drive-through queue analysis based on a scope of work determined by the City of Costa Mesa. The trip generation and queuing analyses utilize data collected at three similar Raising Cane's case study sites in the surrounding areas. The case study trip rates have been compared to trip rates from standardized Institute of transportation Engineers (ITE) trip generation estimates for a similar type of fast-food drive-through use. The trip generation estimates derived from the case studies were approved by the City as the basis for this traffic study.



The Raising Cane's sites used as case study locations are in the cities of Costa Mesa, Laguna Hills, and Orange. A professional traffic data collection firm was used to count the number of vehicles entering and exiting each site, count parking utilization, and tabulate drive-through queue lengths at each case study location for use in this study. Data was collected at each case study site during the mid-day (11 AM - 1 PM) and evening (5 - 7 PM) peak periods for a typical weekday and typical Saturday. Intersection traffic count data for seven key intersections near the Project site were also collected for the same mid-day and evening weekday, and mid-day Saturday time periods.

In accordance with City traffic study guidelines and in consultation with City staff, seven intersections in the immediate vicinity of the Project were selected for intersection operational analysis, as shown in the previously referenced Figure 1. The analysis includes evaluation of the proposed Project during the weekday and Saturday mid-day peak hours and the weekday PM peak hour under the following scenarios:

- Existing Conditions
- Opening Year (2024) Cumulative Conditions without Project
- Opening Year (2024) Cumulative Conditions with Project



Legend

-  Project site
-  Study intersection

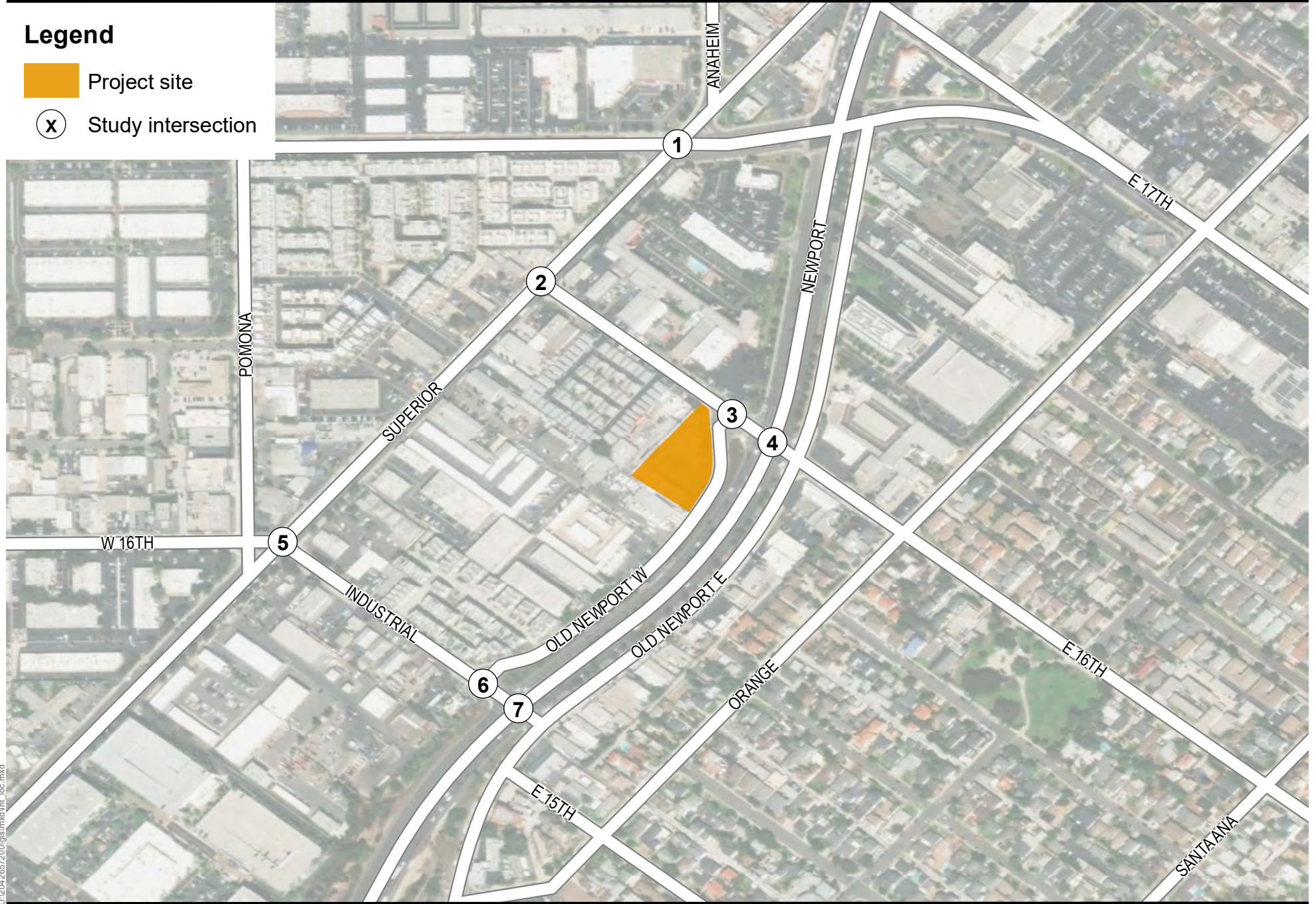

U:\2042657200\gis\mxd\int_loc.mxd



Figure 1
Project Location Map and Study Area Intersections

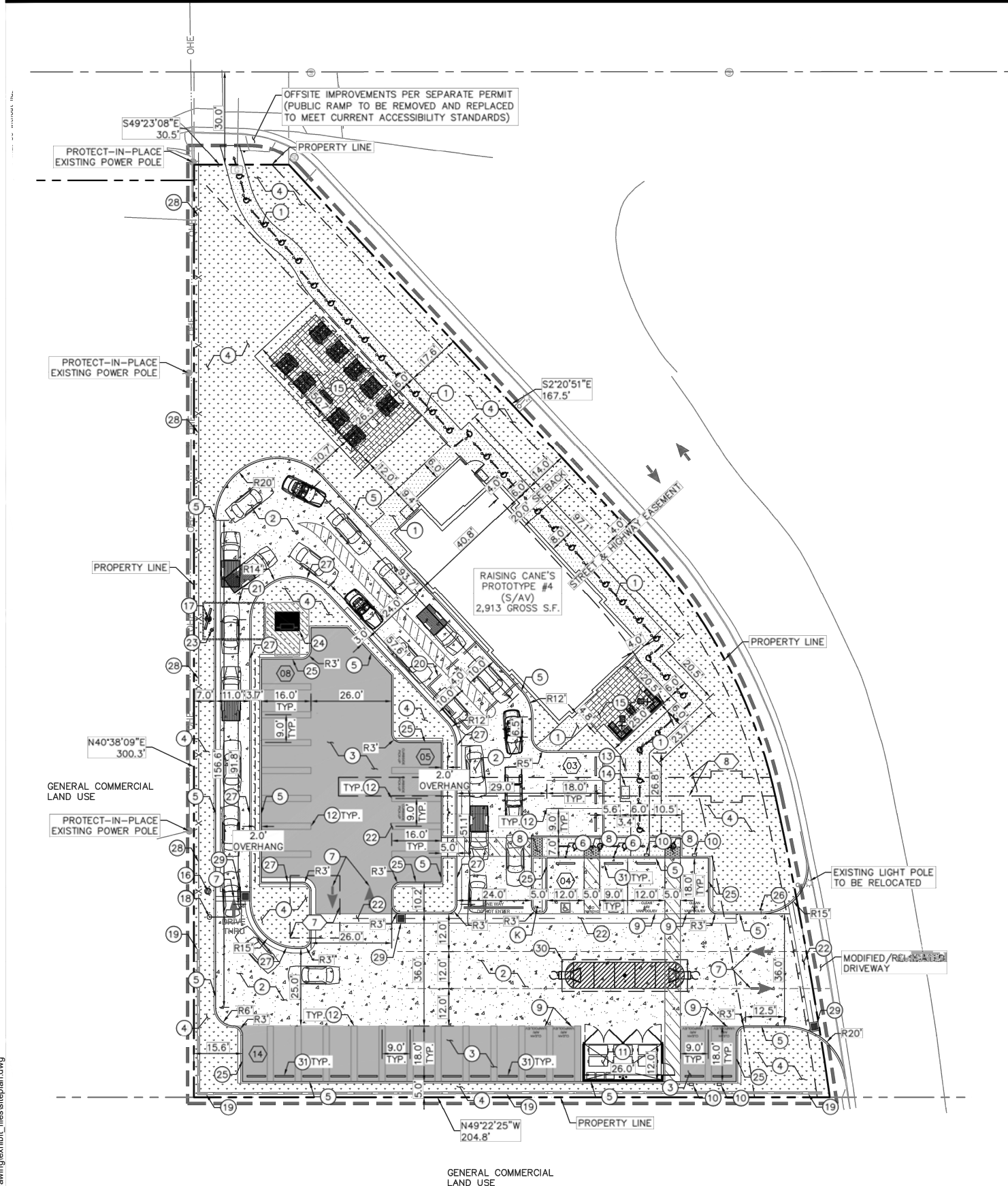

Source: Kimley Horn

Figure 2
Project Site Plan

U:\20-42857200\drawing\exhibit_files\siteplan.dwg



Existing traffic count data was collected in early February 2023 for the study area intersections to represent existing traffic conditions. Opening Year (2024) cumulative conditions represent traffic for the Project's anticipated opening year of 2024. The year-2024 background traffic is estimated by applying an ambient growth rate of one percent per year, added to the existing traffic volumes. In consultation and approved by City staff, a growth rate of one percent per year was calculated based on traffic forecasts obtained from the Orange County Transportation Analysis Model (OCTAM), which includes traffic growth projections generated by cumulative development projects. Project generated traffic is then incrementally added to the 2024 baseline volumes to represent Opening Year (2024) Cumulative Conditions with Project.

1.3 Project Analysis Methodology

To evaluate the potential effect of Project traffic on the surrounding circulation system, a level of service (LOS) analysis utilizing a defined performance criterion determines if a project would cause an undesirable condition at any of the study area intersections during the mid-day or PM peak hours.

For this analysis, the methodology outlined in the Highway Capacity Manual (HCM) Sixth Edition is used, which produces estimates of average vehicle delay as a function of intersection capacity and the volume of traffic passing through the intersection. From this, a corresponding LOS is defined. Traffic LOS is designated "A" through "F" with LOS A representing free flow conditions and LOS F representing severe traffic congestion. The vehicle delay ranges that correspond to LOS A through F, as specified in the HCM, are summarized in Table 1.

Table 1 Intersection Level of Service Ranges (HCM Delay)

LOS	Signal Control Delay	Stop Control Delay
A	0.00 – 10.0 seconds	0.00 – 10.0 seconds
B	10.1 – 20.0 seconds	10.1 – 15.0 seconds
C	20.1 – 35.0 seconds	15.1 – 25.0 seconds
D	35.1 – 55.0 seconds	25.1 – 35.0 seconds
E	55.1 – 80.0 seconds	35.1 – 50.0 seconds
F	Above 80.0 seconds	Above 50.0 seconds

Source: HCM Sixth Edition

Certain LOS values are deemed undesirable by the City. The performance criteria and thresholds used in this analysis are summarized in Table 2 as established by the City of Costa Mesa. Synchro software was used to calculate the intersection delay and LOS.



Table 2 Intersection Performance Criteria

<p>Delay Methodology</p> <p>Calculation Methodology Level of service based on “average vehicle delay” calculated as follows:</p> <ul style="list-style-type: none"> - Synchro/HCM delay-based intersection methodology for traffic signals - HCM Sixth Edition delay-based intersection methodology for stop sign control <p>Performance Standard Level of service D defined as follows:</p> <ul style="list-style-type: none"> - stopped delay to not exceed 55 seconds for signalized intersections - stopped delay to not exceed 35 seconds for stop sign control
<p>Thresholds</p> <p>Would the Project:</p> <ul style="list-style-type: none"> • Worsen an intersection maintained by the City from LOS D or better to LOS E or F
<p>Abbreviations: LOS – Level of Service</p>

2 Traffic Analysis

For comparison purposes, the proposed Project’s anticipated trip generation estimates were prepared using standardized Institute of Transportation Engineers (ITE) 11th Edition trip generation rates for the Fast-Food Restaurant with Drive-Through Window (934) category and compared to the measured case study trip rate.

2.1 Trip Generation Case Study

The number of vehicles entering and exiting the three case study sites during mid-day and evening peak periods on a typical weekday and on a Saturday were collected during the following time periods:

- Thursday from 11:00 AM - 7:00 PM
- Saturday from 11:00 AM - 7:00 PM

Data was collected at the three case study locations listed below. See Appendix A for the driveway entering and exiting traffic volumes data worksheets.

- 1) 3150 Harbor Blvd, Costa Mesa
- 2) 23971 El Toro Road, Laguna Hills
- 3) 2249 N. Tustin Street, Orange



**Raising Cane's Traffic Study
2 Traffic Analysis
October 2023**

The case study trips collected at the three locations mentioned above were summarized and submitted to the City for their review and approval of the specific trip rates to use in this study. Table 3 summarizes the trip generation based on the ITE trip rates as well as the case study derived trip rates for a weekday. As shown in the table, based on standardized ITE trip rates the proposed Project would generate a total of approximately 152 mid-day peak hour trips and 153 PM peak hour trips on a typical weekday. Based on the case study trip rates, the proposed Project is expected to generate a total of approximately 138 mid-day peak hour trips and 161 PM peak hour trips on a typical weekday.

Table 3 Trip Generation Summary based on ITE & Case Study Trip Rates – Weekday

Trip Rates	Amount	Units	Mid-day Peak Hour			PM Peak Hour		
			In	Out	Total	In	Out	Total
Fast-Food Restaurant with Drive-Through Window (934) ¹	-	TSF	26.30	24.27	50.57	25.98	24.96	50.94
Fast-Food Restaurant with Drive-Through Window (Case-study trip rates)	-	TSF	24.07	22.16	46.23	27.27	26.33	53.60
Trip Generation								
Project (based on ITE trip rate)	3.0	TSF	79	73	152	78	75	153
Project (based on case study trip rate)	3.0	TSF	72	66	138	82	79	161
Trip Rate Source: ¹ For the peak hour of generator, Institute of Transportation Engineers (ITE), 11th Edition, 2021, with ITE code in parentheses TSF- Thousand Square Feet								

Similarly, Table 4 summarizes the trip generation based on the ITE trip rates as well as the case study derived trip rates for a Saturday. Note that ITE trip rates are available only for the peak hour of the generator on a Saturday. As shown in the table, based on standardized ITE trip rates the proposed Project would generate a total of approximately 166 peak hour trips on a Saturday. Based on the case study trip rates, the proposed Project is expected to generate a total of approximately 167 mid-day peak hour trips and 150 PM peak hour trips on a Saturday.

Table 4 Trip Generation Summary based on ITE & Case Study Trip Rates – Saturday

Trip Rates	Amount	Units	Saturday Mid-day Peak Hour			Saturday PM Peak Hour		
			In	Out	Total	In	Out	Total
Fast-Food Restaurant with Drive-Through Window (934) ¹	-	TSF	28.18	27.07	55.25	n/a	n/a	n/a
Fast-Food Restaurant with Drive-Through Window (case-study trip rates)	-	TSF	28.75	26.96	55.71	27.03	23.10	50.13
Trip Generation								
Project (based on ITE trip rate)	3.0	TSF	85	81	166	n/a	n/a	n/a
Project (based on case study trip rate)	3.0	TSF	86	81	167	81	69	150
Trip Rate Source: ¹ For the peak hour of generator, Institute of Transportation Engineers (ITE), 11th Edition, 2021, with ITE code in parentheses TSF- Thousand Square Feet n/a – not available								



Raising Cane's Traffic Study
2 Traffic Analysis
October 2023

City engineers reviewed the case study trip generation data and concurred that the trip rates derived from the case study are the most appropriate for use in this study. For ADT purposes, ITE trip rate was used. Table 5 summarizes the proposed Project trip generation based on the case study trip rates for a weekday. As shown in the table, the proposed Project is expected to generate a total of approximately 138 mid-day peak hour trips and 161 PM peak hour trips. A pass-by trip reduction of 50 percent for the peak hour is applied based on the data for fast-food restaurants with drive-through window provided in the ITE Trip Generation Handbook, Third Edition. Applying the pass-by trip reduction, the net new trips generated by the Project are approximately 69 trips during the mid-day peak hour and 81 trips during the PM peak hour on a typical weekday. The proposed Project is expected to generate 1,402 daily trips. For ADT, a 25 percent pass-by trip reduction was applied based on the direction from the City. Therefore, the net new daily Project trips generated by the Project would be 1,051 trips.

When compared to the prior commercial retail (furniture store) use on-site, the additional trips generated by the Project are approximately 58 during the mid-day peak hour and 68 during the PM peak hour, and 892 daily trips on a typical weekday. Based on the ITE trip rates for the furniture store, the Project generates 13 PM peak hour trips and 159 daily trips. Mid-day peak hour trips are estimated to be 11 trips based on an assumption that the mid-day peak hour trips are 80% of the PM peak hour trips. This information is provided for comparison purposes only since the existing retail use (furniture store) is currently unoccupied.

Table 5 Trip Generation Summary based on Case Studies of Local Raising Cane's – Weekday

Trip Rates	Amount	Units	Mid-day Peak Hour			PM Peak Hour			ADT
			In	Out	Total	In	Out	Total	
Furniture Store (890) ¹	--	TSF	0.20 ³	0.22 ³	0.42 ³	0.24	0.28	0.52	6.30
Fast-Food Restaurant with Drive-Through Window (Case study trip rates except ADT)	--	TSF	24.07	22.16	46.23	27.27	26.33	53.60	467.48
Trip Generation									
Raising Cane's (proposed)	3.0	TSF	72	66	138	82	79	161	1,402
Pass-by/diverted trips ² (50%/25%) ³	--	--	-36	-33	-69	-41	-39	-80	-351
Net New Project Trips	--	--	36	33	69	41	40	81	1,051
Furniture Store (existing)	25.2	TSF	-5 ⁴	-6 ⁴	-11 ⁴	-6	-7	-13	-159
Additional trips compared to existing use (for comparison purposes only)	--	--	31	27	58	35	33	68	892
Trip Rate Source: ¹ Institute of Transportation Engineers (ITE), 11 th Edition, 2021, with ITE code in parentheses ² Pass-by/diverted trip reduction rate for peak hours from ITE Trip Generation Handbook, 3rd Edition ³ Pass-by/diverted trip reduction rate of 50% for peak hour and 25% for ADT based on City's direction ⁴ Mid-day furniture store ITE trip rate not available, assumed equal to 80% of the PM peak hour trip rate. Furniture store trips are shown for comparison purposes only. TSF - Thousand Square Feet n/a - not available									

Similarly, Table 6 shows summary of the proposed Project trip generation based on the case study trip rates for a Saturday. As shown in the table, the proposed Project is expected to generate a total of



Raising Cane's Traffic Study
2 Traffic Analysis
October 2023

approximately 167 peak hour trips. A pass-by trip reduction of 50 percent is applied based on the data for fast-food restaurants with drive-through window provided in the ITE Trip Generation Handbook, Third Edition. Applying the pass-by trip reduction, the net new trips generated by the Project are approximately 83 trips during the mid-day peak hour.

When compared to the prior commercial retail (furniture store) use on-site, the additional trips generated by the Project are approximately 55 during the peak hour on a Saturday. This information is provided for comparison purposes only since the existing retail use (furniture store) is currently unoccupied.

Table 6 Trip Generation Summary based on Case Studies of Local Raising Cane's – Saturday

Trip Rates	Amount	Units	Mid-day Peak Hour		
			In	Out	Total
Furniture Store (890) ¹	--	TSF	0.59	0.51	1.10
Fast-Food Restaurant with Drive-Through Window (Case study trip rates)	--	TSF	28.75	26.96	55.71
Trip Generation					
Raising Cane's (proposed)	3.0	TSF	86	81	167
Pass-by/diverted trips ² (50%)	--	--	-43	-41	-84
Net New Project Trips	--	--	43	40	83
Furniture Store (existing)	25.2	TSF	-15	-13	-28
Additional trips compared to existing use (for comparison purposes only)	--	--	28	27	55
Trip Rate Source: ¹ For the peak hour of generator, Institute of Transportation Engineers (ITE), 11th Edition, 2021, with ITE code in parentheses ² ITE Trip Generation Handbook, 3rd Edition TSF- Thousand Square Feet					

2.2 Study Area

In accordance with City traffic study guidelines and in consultation with City staff, the following seven study intersections in the vicinity of the Project site were selected for analysis:

1. Superior Avenue and 17th Street (Signal)
2. Superior Avenue and E. 16th Street (Side-street Stop)
3. Old Newport Boulevard Frontage Road and E. 16th Street (Side-street Stop)
4. Newport Boulevard and E. 16th Street (Signal)
5. Superior Avenue and W. 16th Street/ Industrial Way (Signal)
6. Old Newport Boulevard Frontage Road and Industrial Way (Side-street Stop)
7. Newport Boulevard and Industrial Way (Signal)



Existing traffic count data was collected in early February 2023 for seven study area intersections during the mid-day (11 AM - 1 PM) and evening (5 - 7 PM) peak periods for a typical weekday and during the mid-day (11 AM - 1 PM) on a typical Saturday. Traffic count data sheets are provided in Appendix B. See Figure 3 for the Project study area intersections and the existing intersection lane geometry, Figure 4 for existing mid-day peak hour volumes, Figure 5 for the existing PM peak hour volumes, and Figure 6 for Saturday mid-day peak hour volumes.

The results of the existing conditions intersection LOS analysis are shown in Table 7. The study area intersections were analyzed using the HCM delay methodology for signalized and unsignalized intersections. Current signal timing data was provided by the City for the analysis. Detailed LOS calculation worksheets are provided in Appendix C. The table shows that each study intersection currently operates at LOS C or better based on the average vehicle delay during both the mid-day and the PM peak hour conditions on a typical weekday, as well as during the Saturday peak hour.

Table 7 Intersection LOS Summary – Existing Conditions

Int #	Intersection Name	Control Type	Weekday				Saturday	
			Mid-Day		PM Peak Hour		Mid-Day	
			Delay	LOS	Delay	LOS	Delay	LOS
1	Superior & 17th	Signal	22.8	C	23.5	C	19.5	B
2	Superior & E 16th	TWSC	15.5	C	16.1	C	13.8	B
3	Old Newport W & E 16th	TWSC	10.1	B	9.4	A	9.6	A
4	Newport & E 16th	Signal	17.6	B	18.0	B	18.9	B
5	Superior & W 16th/Industrial	Signal	26.0	C	28.9	C	25.8	C
6	Old Newport W & Industrial	TWSC	11.3	B	10.4	B	9.9	A
7	Newport & Industrial	Signal	16.0	B	15.0	B	11.1	B

Note:
Based on traffic counts collected in February 2023
LOS - Level of Service
Delay - Average vehicle delay (seconds/vehicle) for movements subject to stopping

2.3 Project Trip Distribution

The Project's anticipated trip distribution percentages were derived based on the Project site's location in relation to the surrounding uses while taking into account the proposed driveway locations, roadway lane geometry, existing traffic flow patterns, and engineering judgement. Overall, approximately 50 percent of the Project trips are expected to be oriented towards the north on Old Newport Boulevard and 50 percent of the Project trips oriented towards the south, with 25 percent continuing on Newport Boulevard and the remaining 25 percent distributed almost equally towards the east and the west. See Figure 7 for the Project trip distribution and Figure 8, Figure 9, and Figure 10 for the weekday mid-day peak hour, weekday PM peak hour, and Saturday mid-day peak hour net Project trips, respectively. The corresponding pass-by Project trip estimates are shown in Figure 11, Figure 12, and Figure 13, respectively.



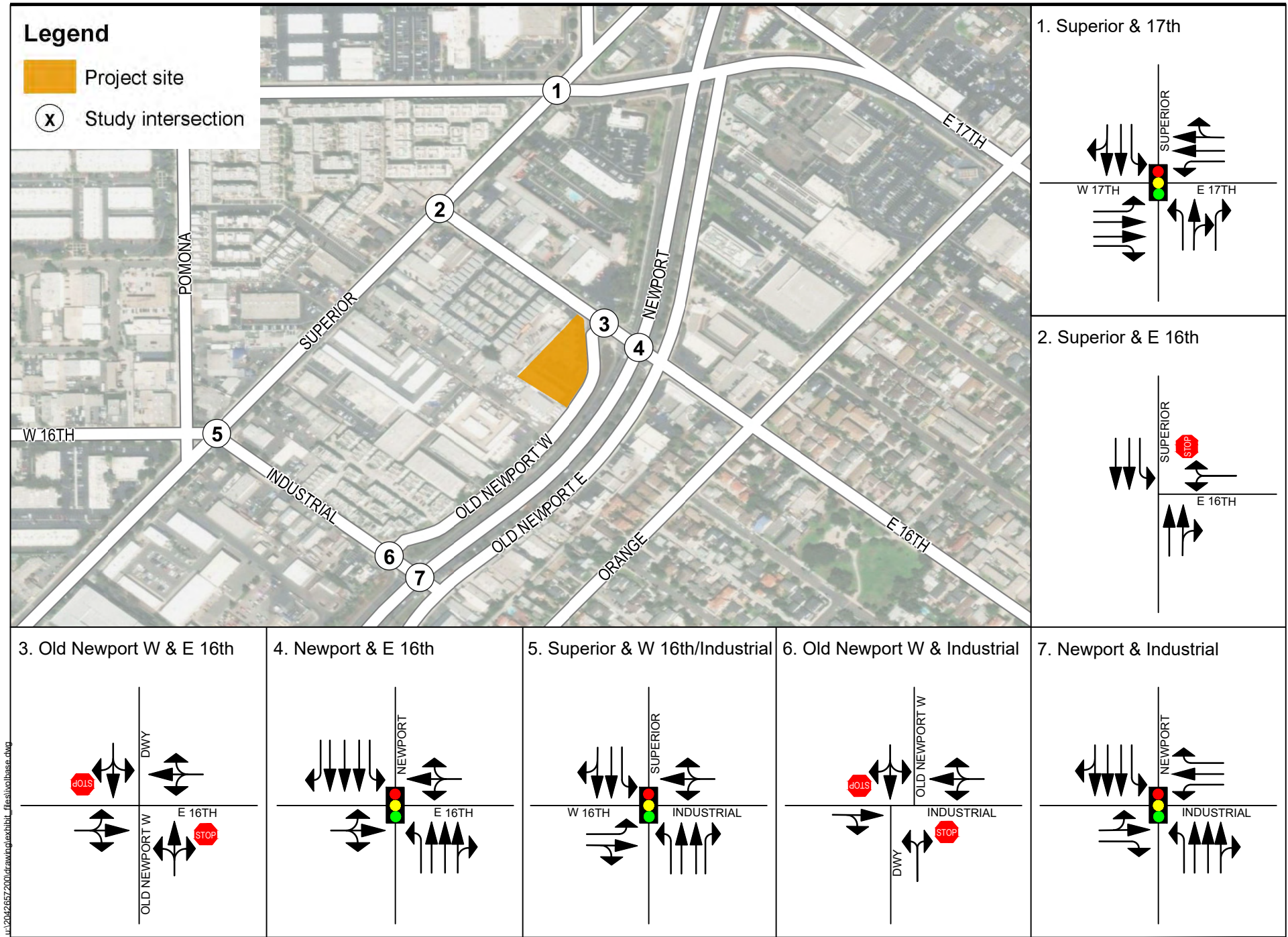

u:\2012\2657200\drawing\exhibit_files\wbase.dwg



Figure 3
Existing Intersection Lane Configurations

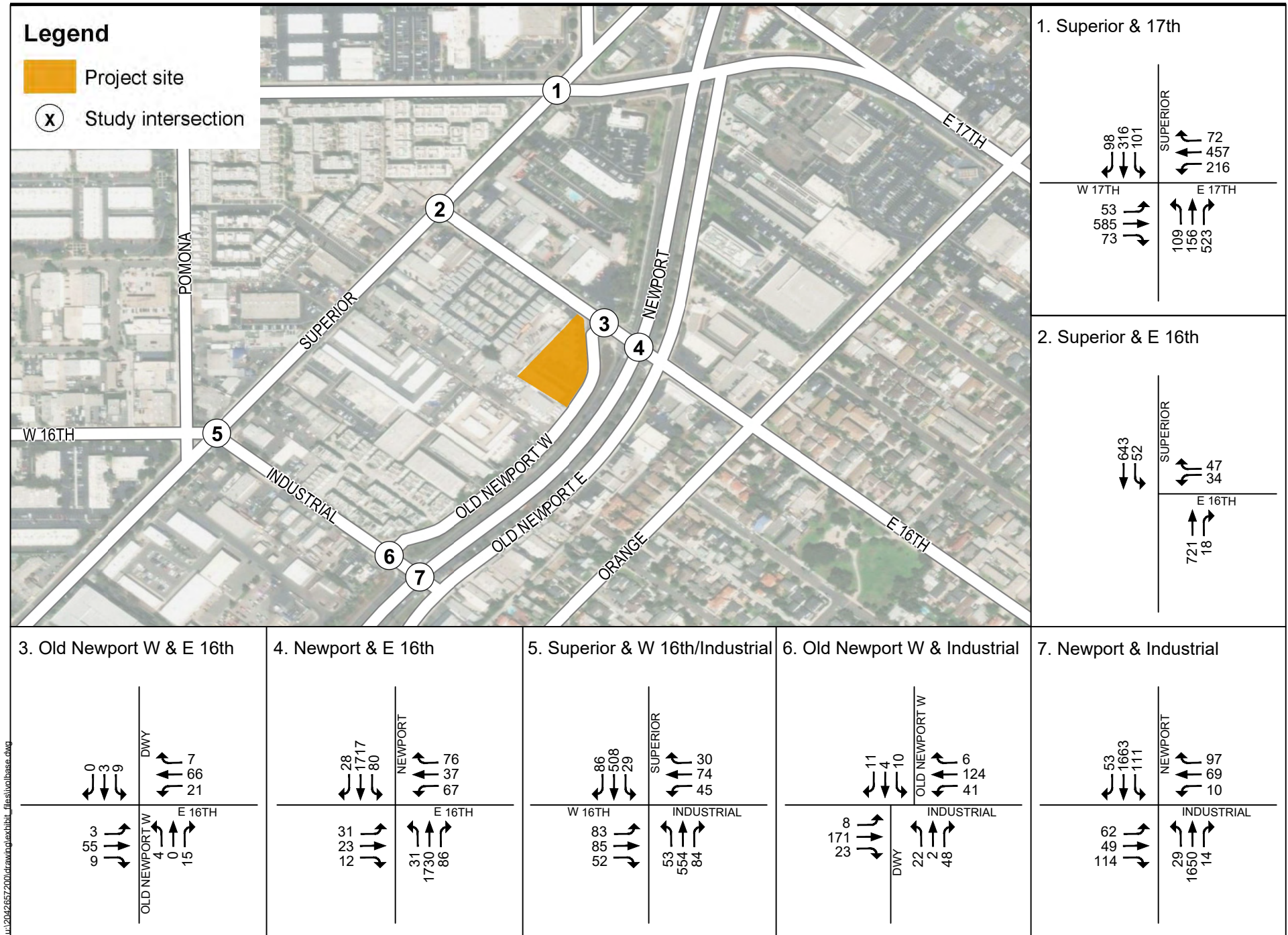

\\120426572001\drawing\exhibit_files\locbase.dwg



Figure 4
Existing Mid-Day Peak Hour Volumes - Weekday

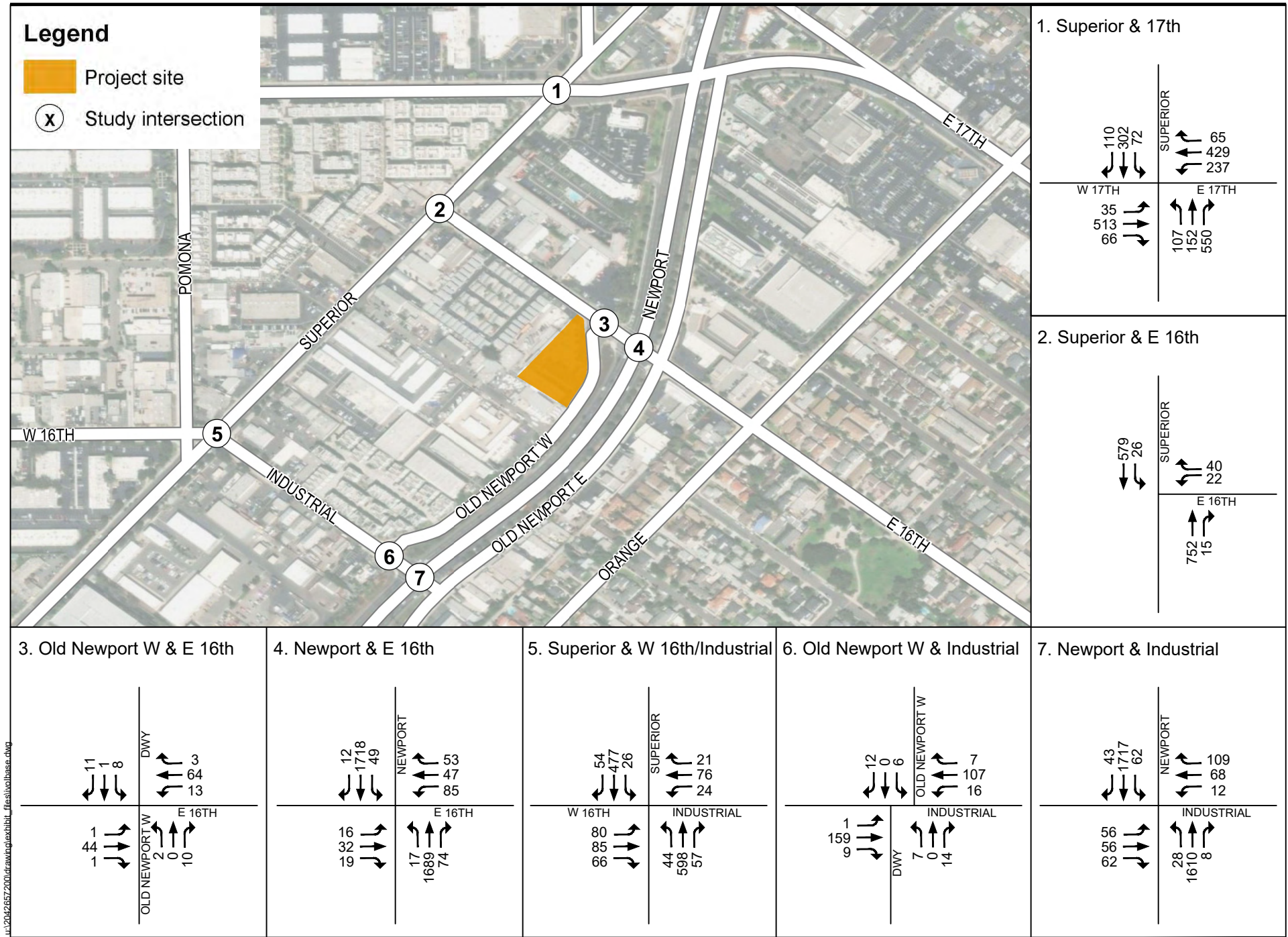

\\120126572001\drawing\exhibit_files\locbase.dwg



Figure 5
Existing PM Peak Hour Volumes - Weekday

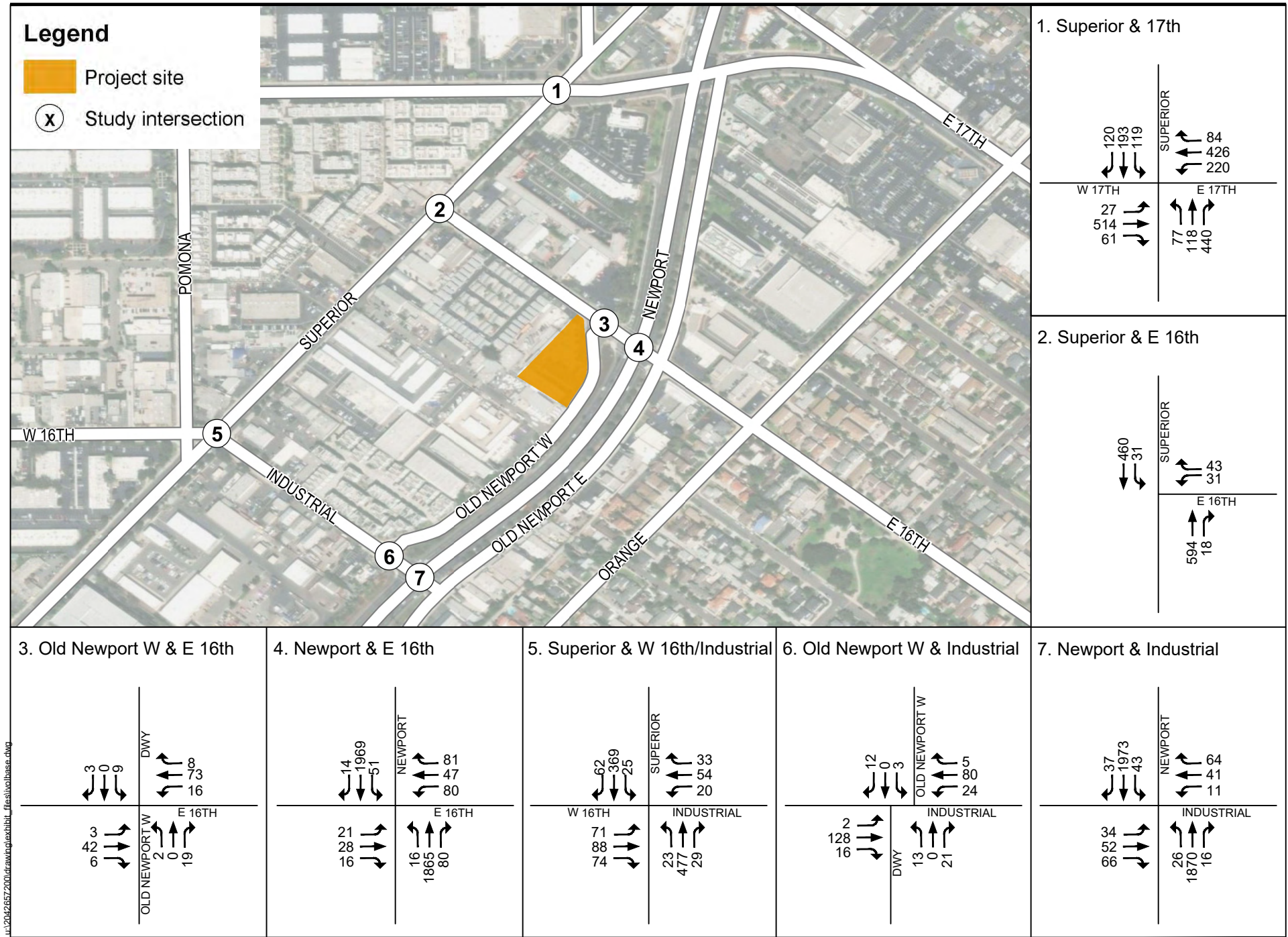

\\12042657200\drawing\exhibit_files\workspace.dwg



Figure 6
Existing Mid-Day Peak Hour Volumes - Saturday

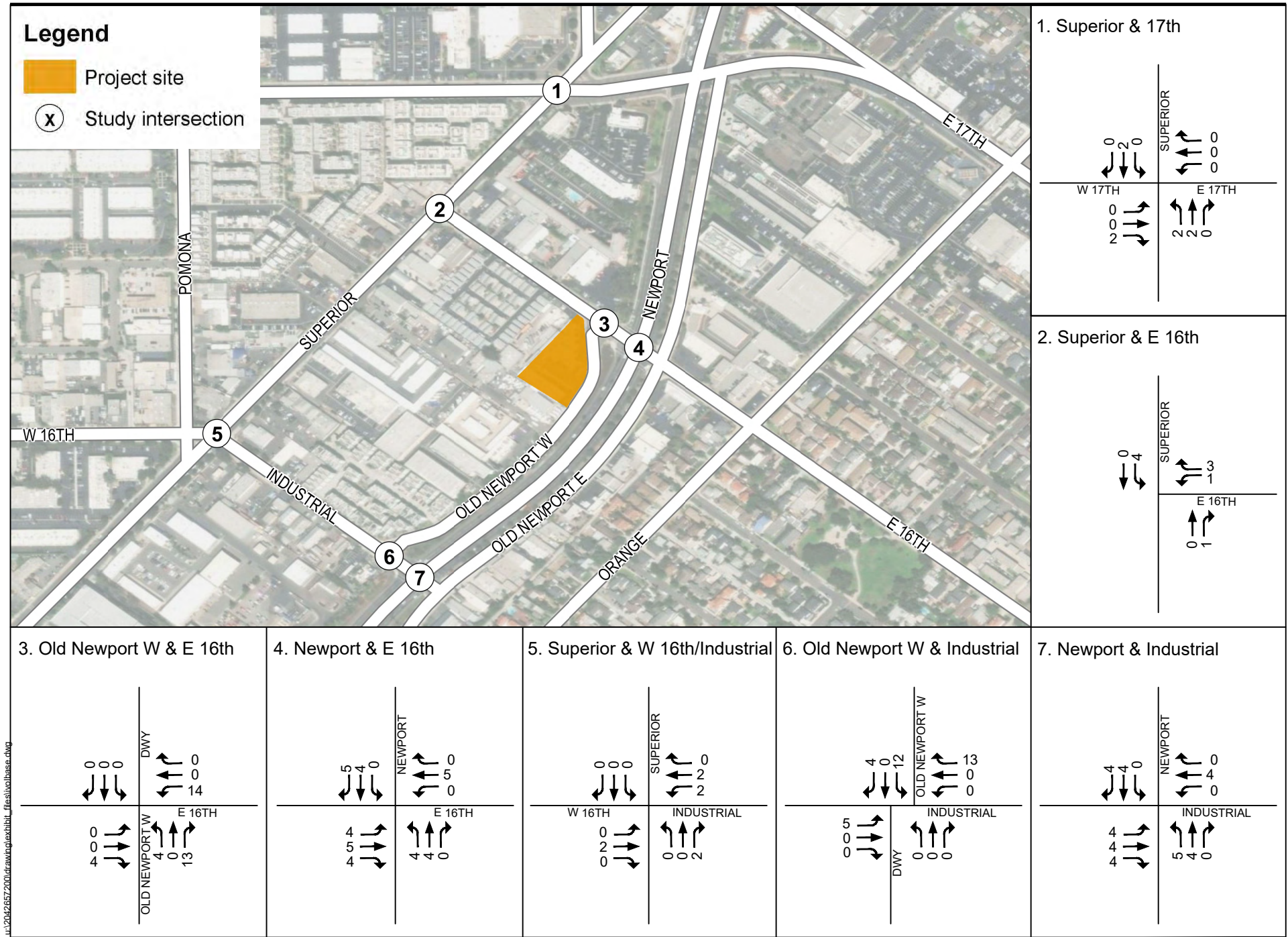

\\120426572001\drawing\exhibit_files\lucibase.dwg



Figure 8
Net Project Trips - Mid-Day Peak Hour - Weekday

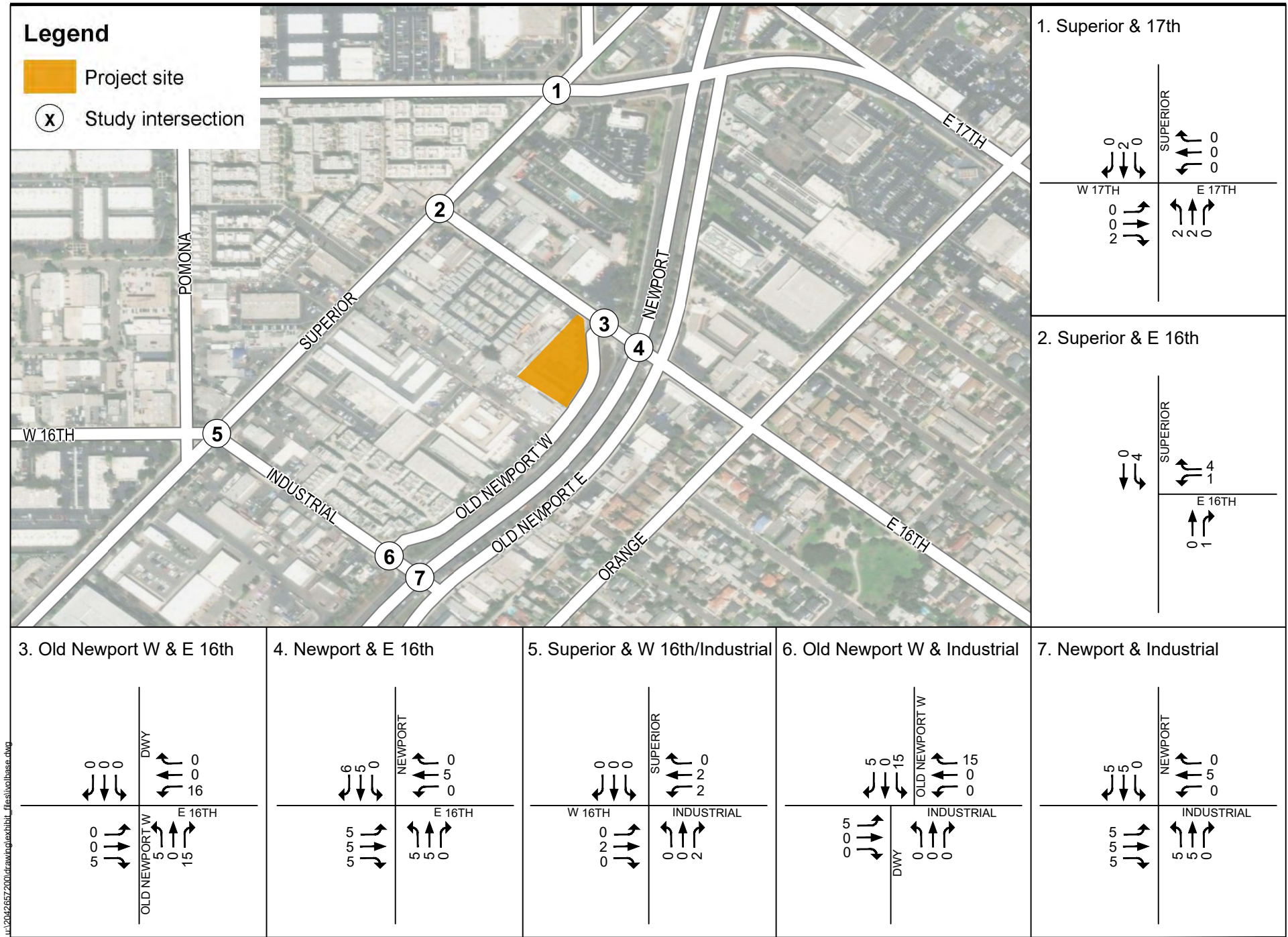

Jul 2012 2:55:20 PM drawing\exhibit_files\subbase.dwg



Figure 9
Net Project Trips - PM Peak Hour - Weekday

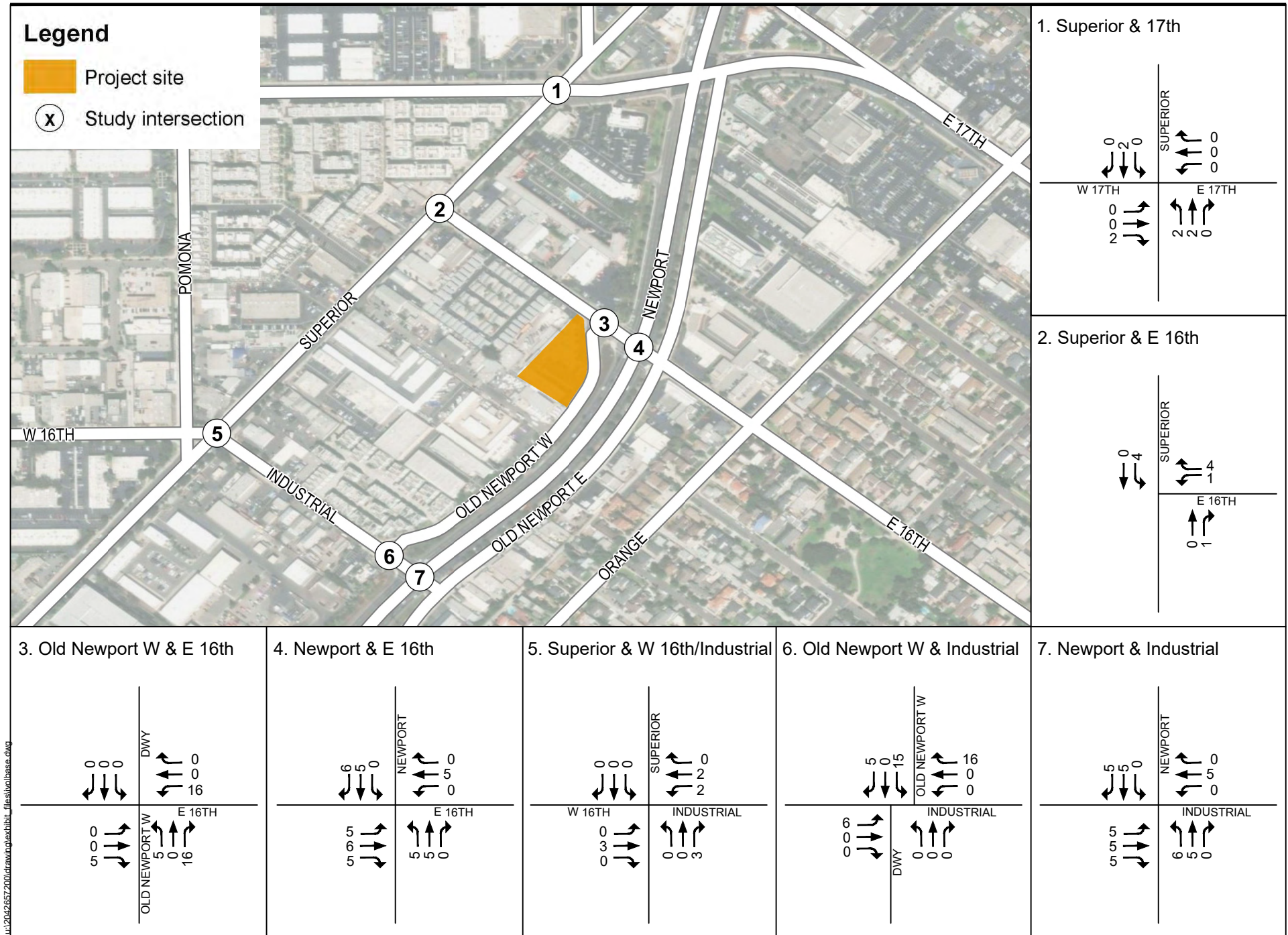
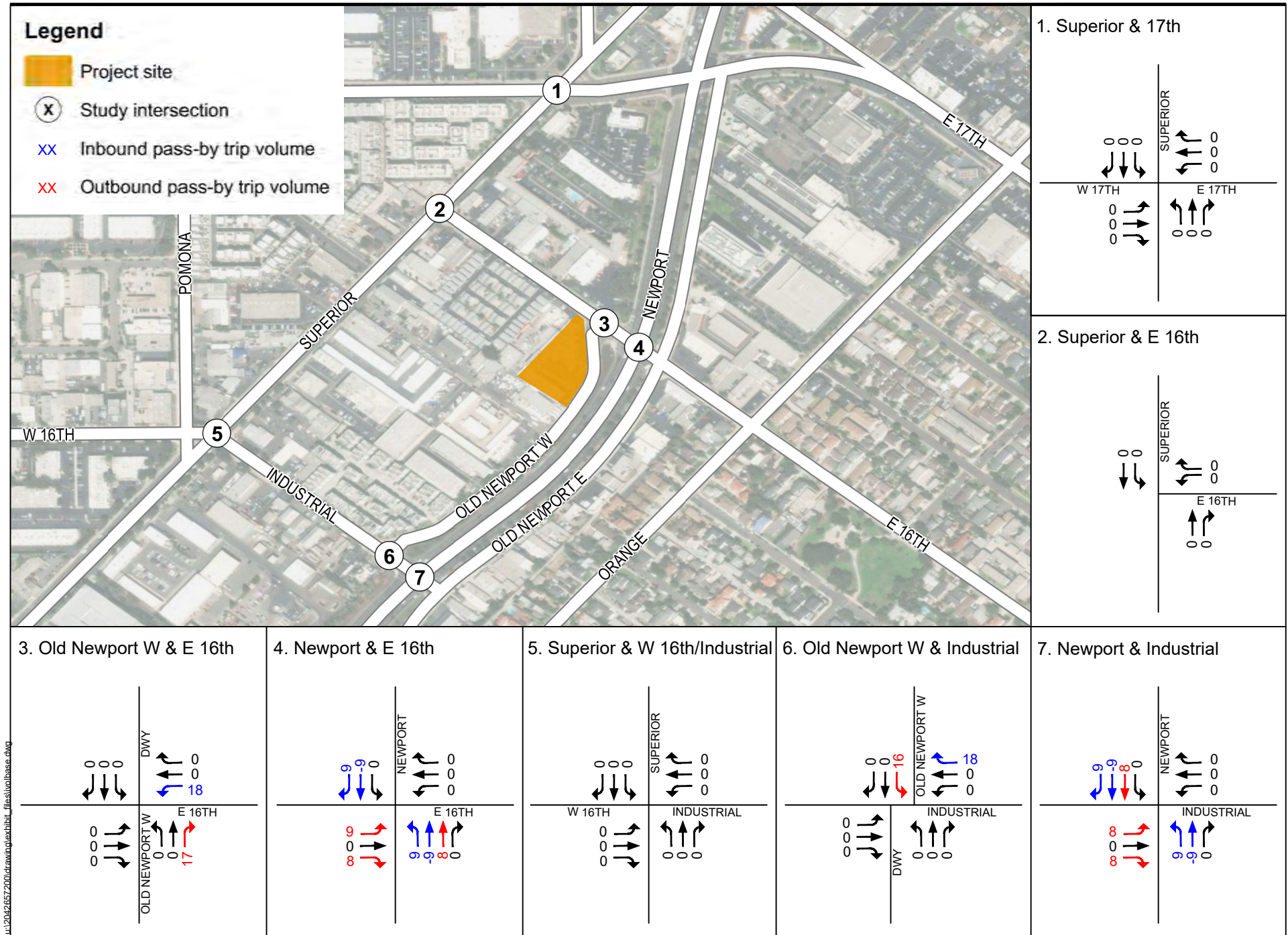

Figure 10

Net Project Trips - Mid-Day Peak Hour - Saturday



\\120126572001\drawing\exhibit_files\wcbase.dwg



Figure 11

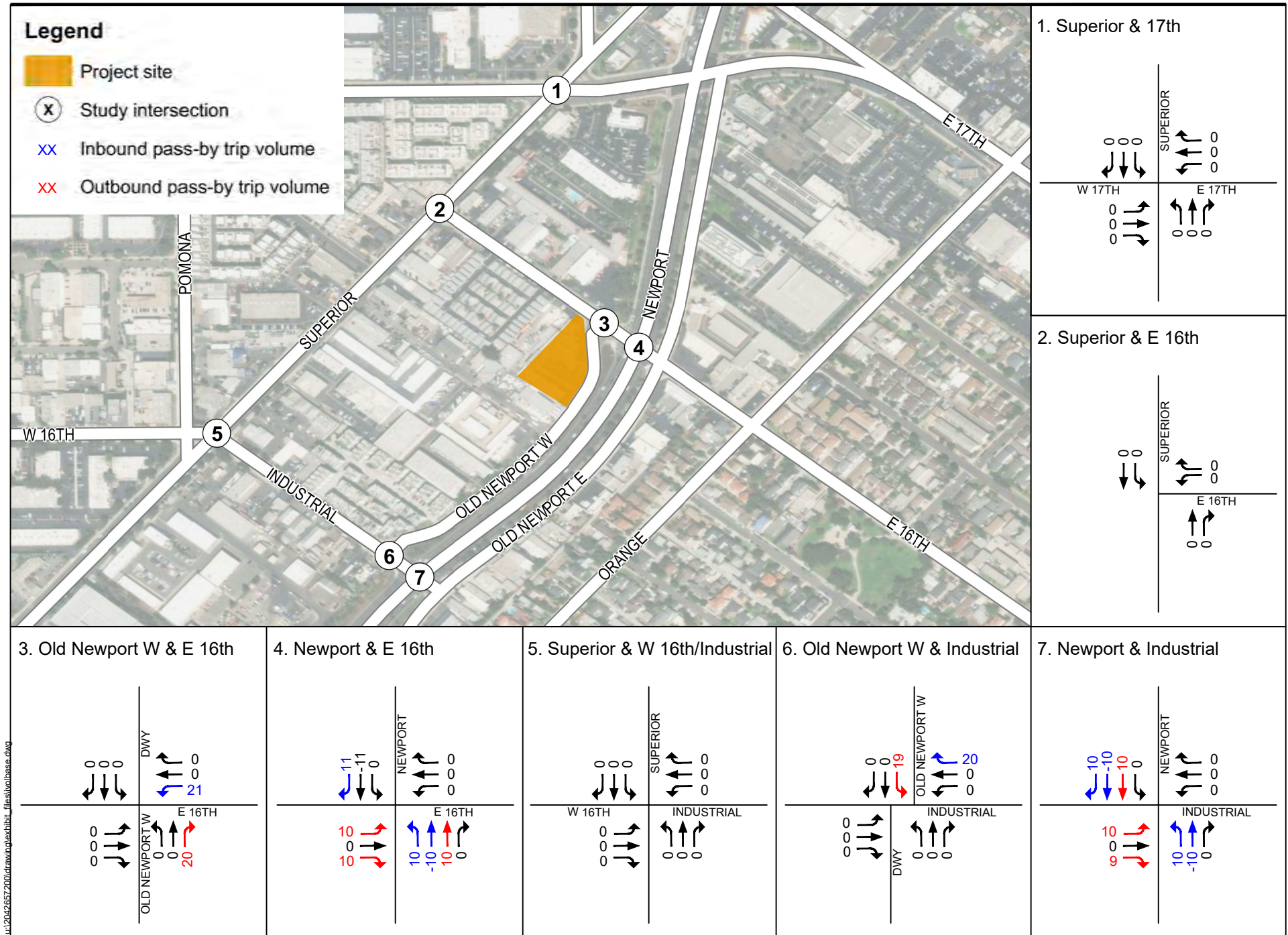

Jul 2019 2:56:22 PM drawing\exhibit_files\wcbase.dwg



Figure 12
Pass-By Project Trips - PM Peak Hour - Weekday

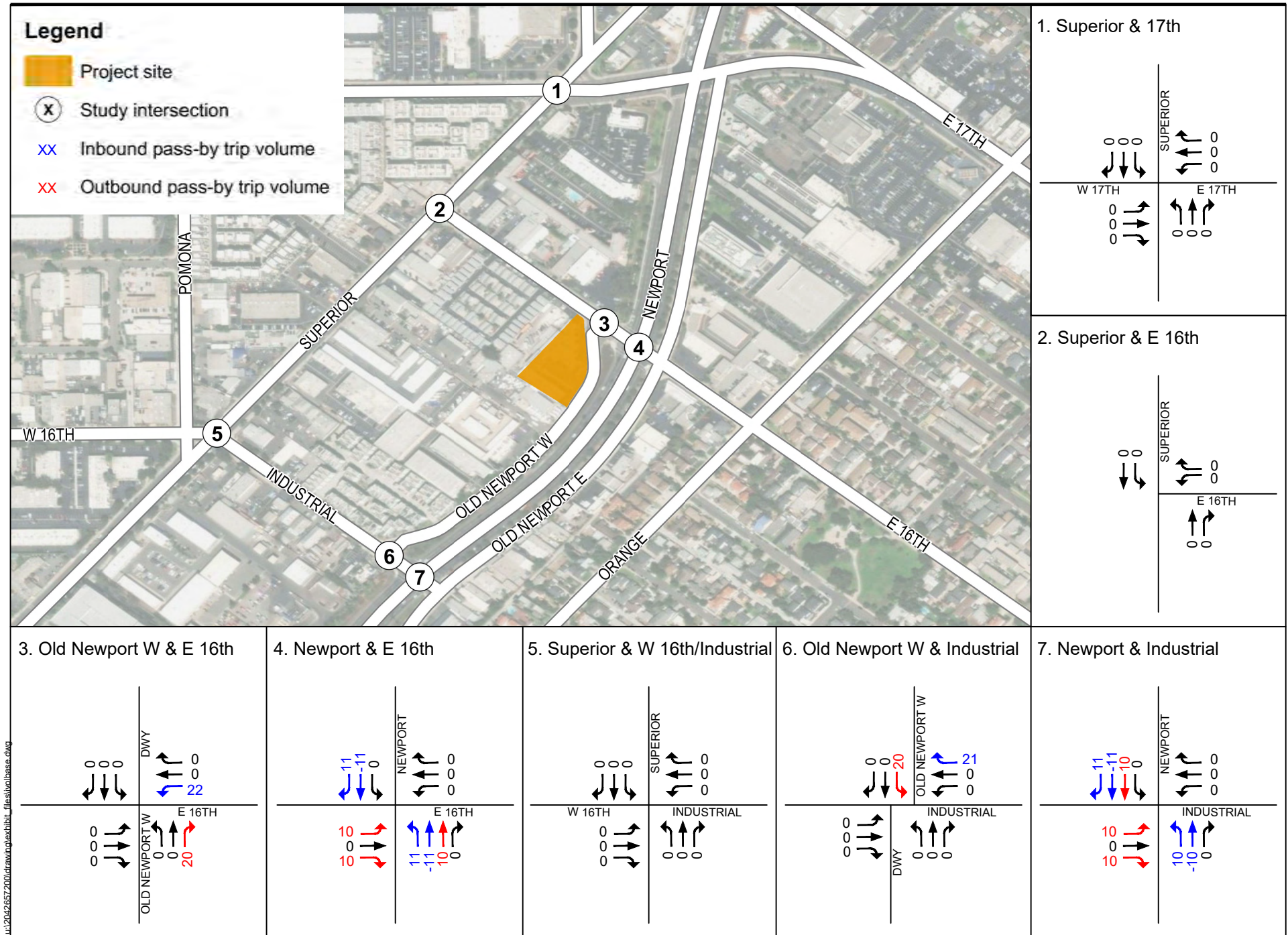

Jul 2019 2:56:22 PM drawing\exhibit_files\subbase.dwg



Figure 13
Pass-By Project Trips - Mid-Day Peak Hour - Saturday

2.4 Opening Year (2024) Cumulative Conditions Analysis

The Project is expected to be built out within a year in 2024. A growth rate of one percent per year was calculated based on traffic forecasts obtained from OCTAM, which includes traffic growth projections generated by cumulative development projects. In consultation and approval from the City staff, a growth rate of one percent per year was used to factor the existing traffic counts to obtain baseline opening day volumes without the Project. The total volume of trips generated by the proposed Project (net new trips plus pass-by adjustments) were added to the Opening Year (2024) cumulative conditions without Project to obtain Opening Year (2024) cumulative conditions with-Project volumes.

Figure 14 and Figure 15 show the Opening Year (2024) cumulative conditions without-Project mid-day peak hour volumes and PM peak hour volumes, respectively for a weekday. Figure 16 shows the Opening Year (2024) cumulative conditions without-Project mid-day peak hour volumes on a Saturday. Figure 17 and Figure 18 show the Opening Year (2024) cumulative conditions with-Project mid-day peak hour volumes and PM peak hour volumes, respectively on a weekday. Figure 19 shows the Opening Year (2024) cumulative conditions with-Project mid-day peak hour volumes on a Saturday.

Peak hour delay values and LOS that correspond with the Opening Year (2024) cumulative conditions without and with Project traffic volumes can be found in Table 8, which provides a comparison between the two scenarios. The signalized and unsignalized study intersections were analyzed based on HCM delay methodology using Synchro software. Current signal timing data was provided by the City for the analysis. Detailed LOS calculation worksheets are provided in Appendix C. The table shows that the study intersections would continue to operate at LOS C or better during the mid-day peak hour and PM peak hour on a typical weekday as well as during the mid-day peak hour on a Saturday.

Table 8 Intersection LOS Summary – Opening Year (2024) Cumulative Conditions

Int #	Intersection Name	Opening Year (2024) Cumulative Conditions without Project						Opening Year (2024) Cumulative Conditions with Project					
		Weekday				Saturday		Weekday				Saturday	
		Mid-Day		PM		Mid-Day		Mid-Day		PM		Mid-day	
		Delay	LOS	Delay	LOS	Delay	LOS	Delay	LOS	Delay	LOS	Delay	LOS
1	Superior & 17th	23.0	C	23.5	C	19.5	B	23.0	C	23.7	C	19.5	B
2	Superior & E 16th	15.6	C	16.2	C	13.9	B	15.8	C	16.4	C	14.0	B
3	Old Newport W & E 16th	10.1	B	9.4	A	9.6	A	11.1	B	10.1	B	10.5	B
4	Newport & E 16th	17.9	B	18.0	B	18.9	B	19.5	B	20.4	C	22.0	C
5	Superior & W 16th/Industrial	26.1	C	28.9	C	25.8	C	26.2	C	29.2	C	26.1	C
6	Old Newport W & Industrial	11.3	B	10.4	B	10.0	B	12.9	B	12.3	B	11.1	B
7	Newport & Industrial	16.2	B	15.0	B	11.1	B	17.9	B	17.8	B	13.3	B
Note: Cumulative background conditions based on traffic counts collected in February 2023 and OCTAM growth projections LOS - Level of Service Delay - Average vehicle delay (seconds/vehicle) for movements subject to stopping													



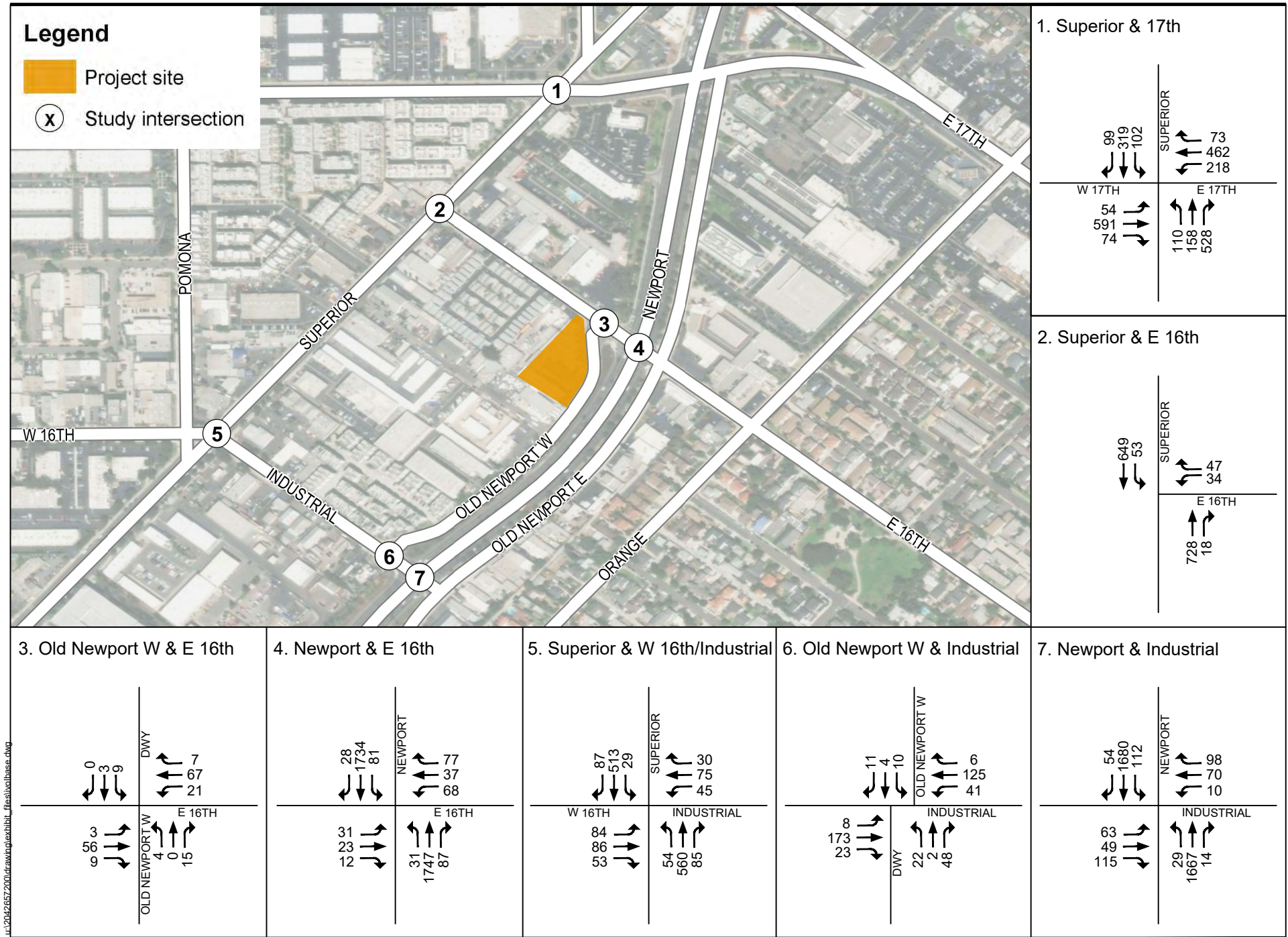

\\120126572001\drawing\exhibit_files\locbase.dwg



Figure 14
Opening Year (2024) Cumulative Conditions No Project - Mid-Day Peak Hour Volumes - Weekday

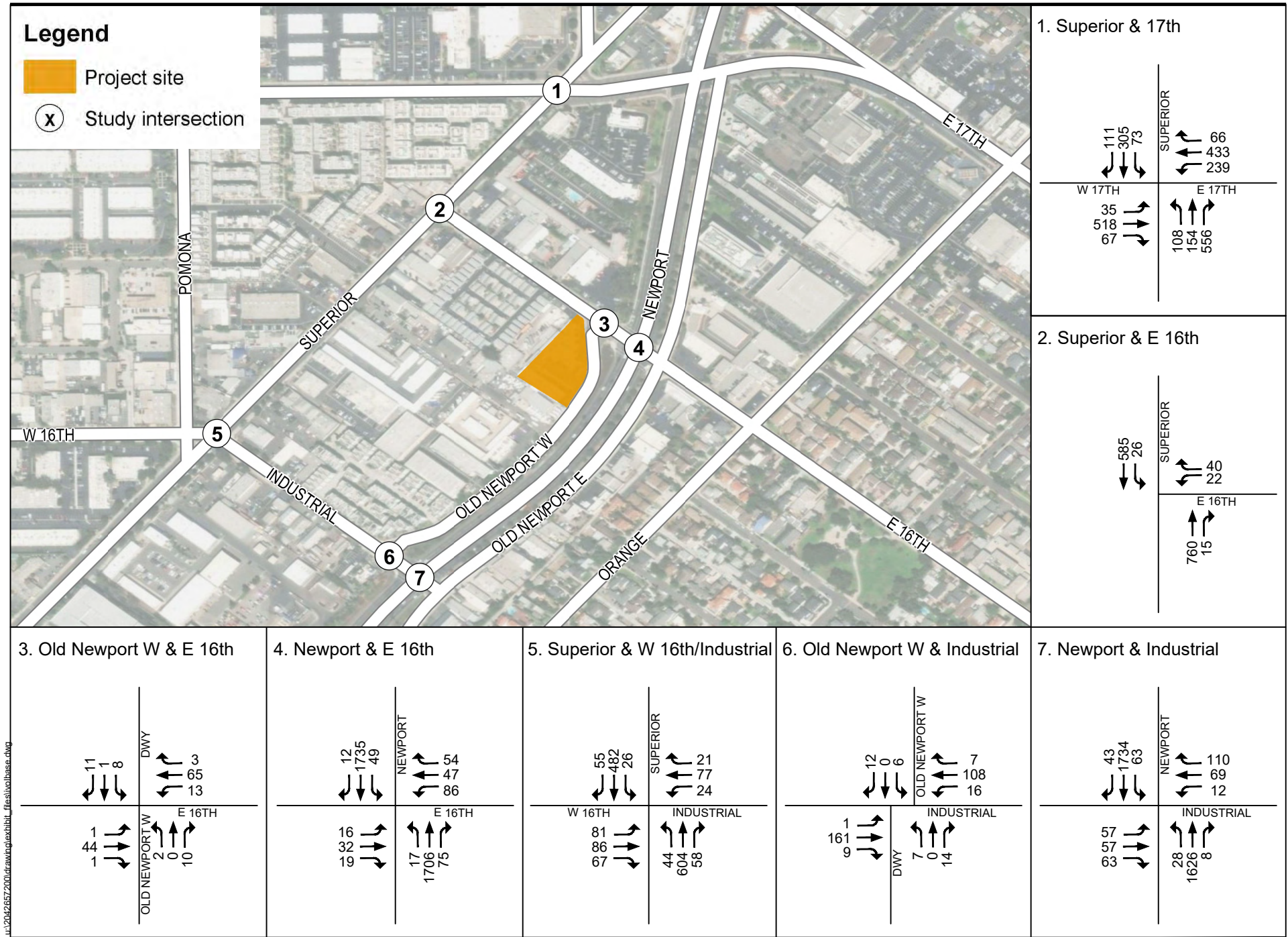

\\112012657200\drawing\exhibit_files\workspace.dwg



Figure 15
Opening Year (2024) Cumulative Conditions No Project - PM Peak Hour Volumes - Weekday

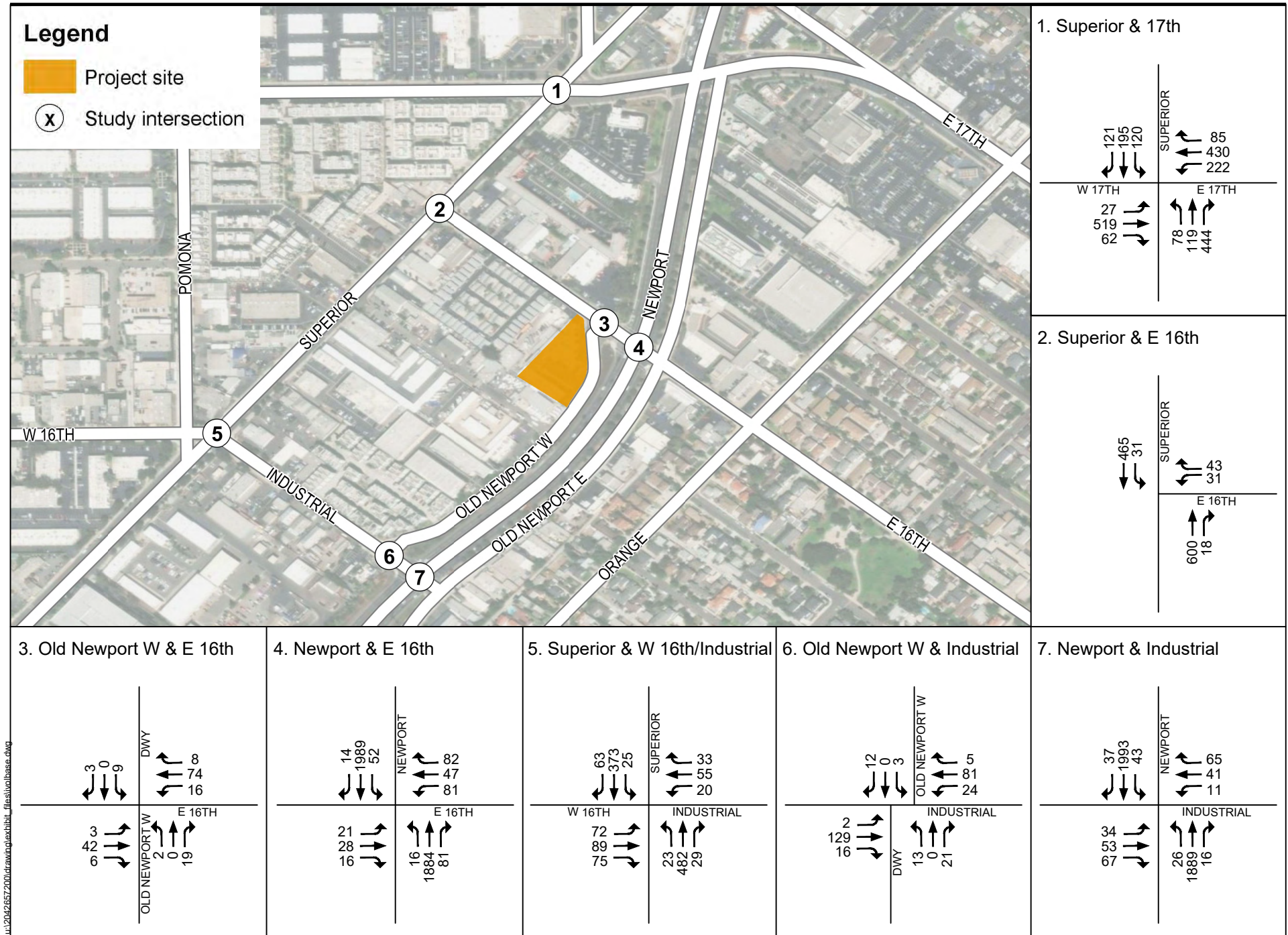

\\120126572001\drawing\exhibit_files\locbase.dwg



Figure 16
Opening Year (2024) Cumulative Conditions No Project - Mid-Day Peak Hour Volumes - Saturday

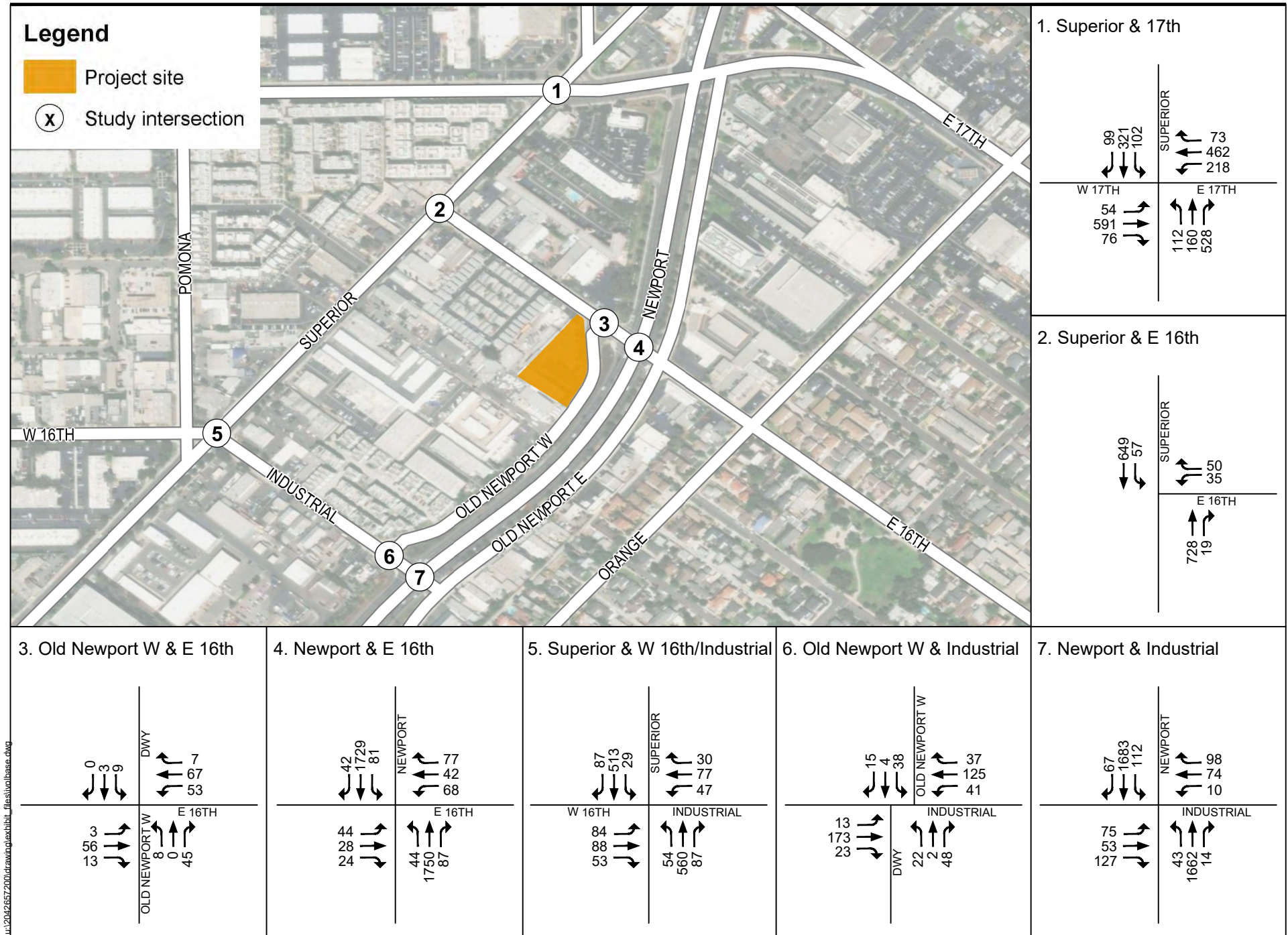

\\u:\2024\2657200\drawing\exhibit_files\locbase.dwg

Figure 17

Opening Year (2024) Cumulative Conditions with-Project - Mid-Day Peak Hour Volumes - Weekday

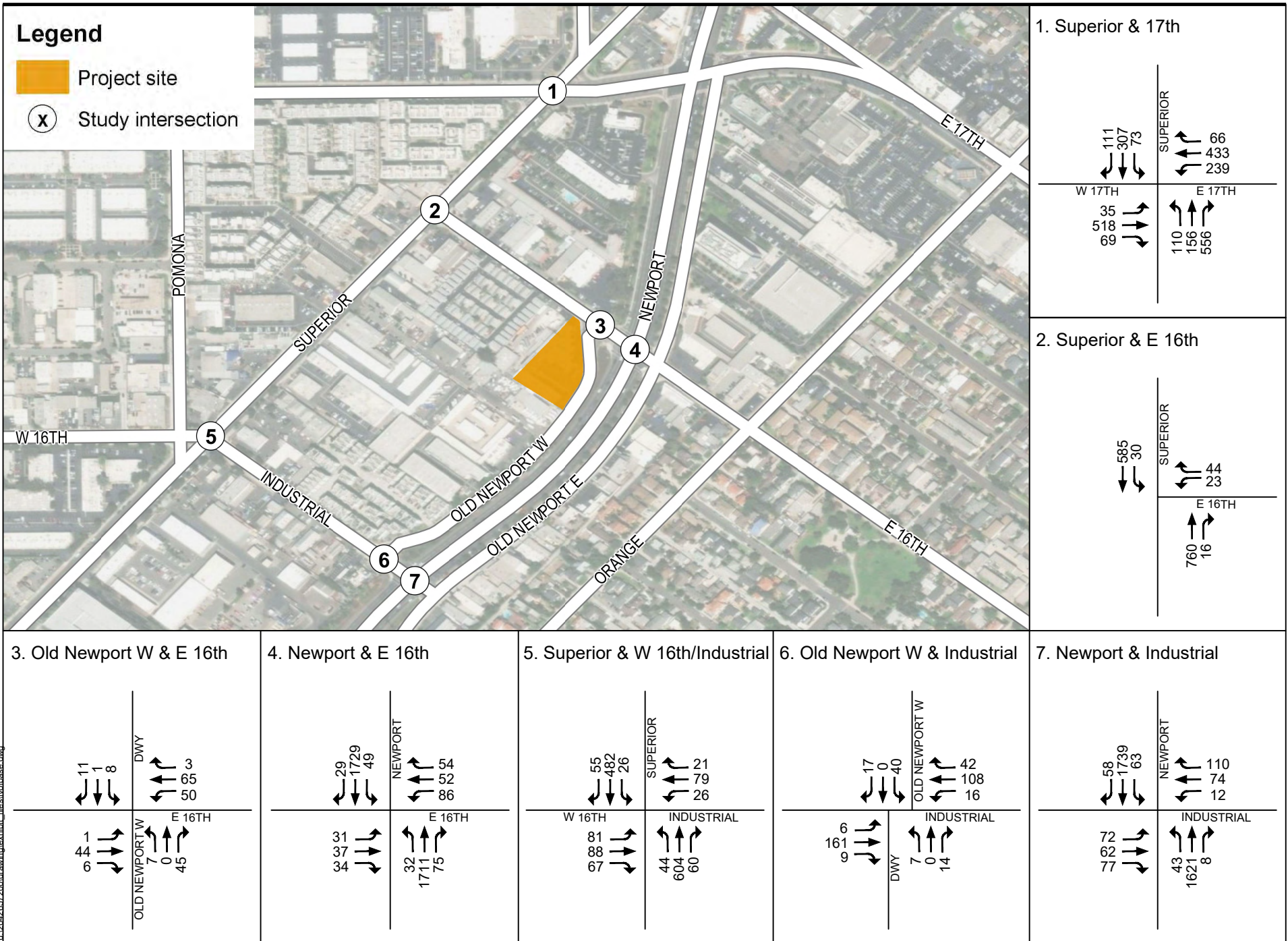
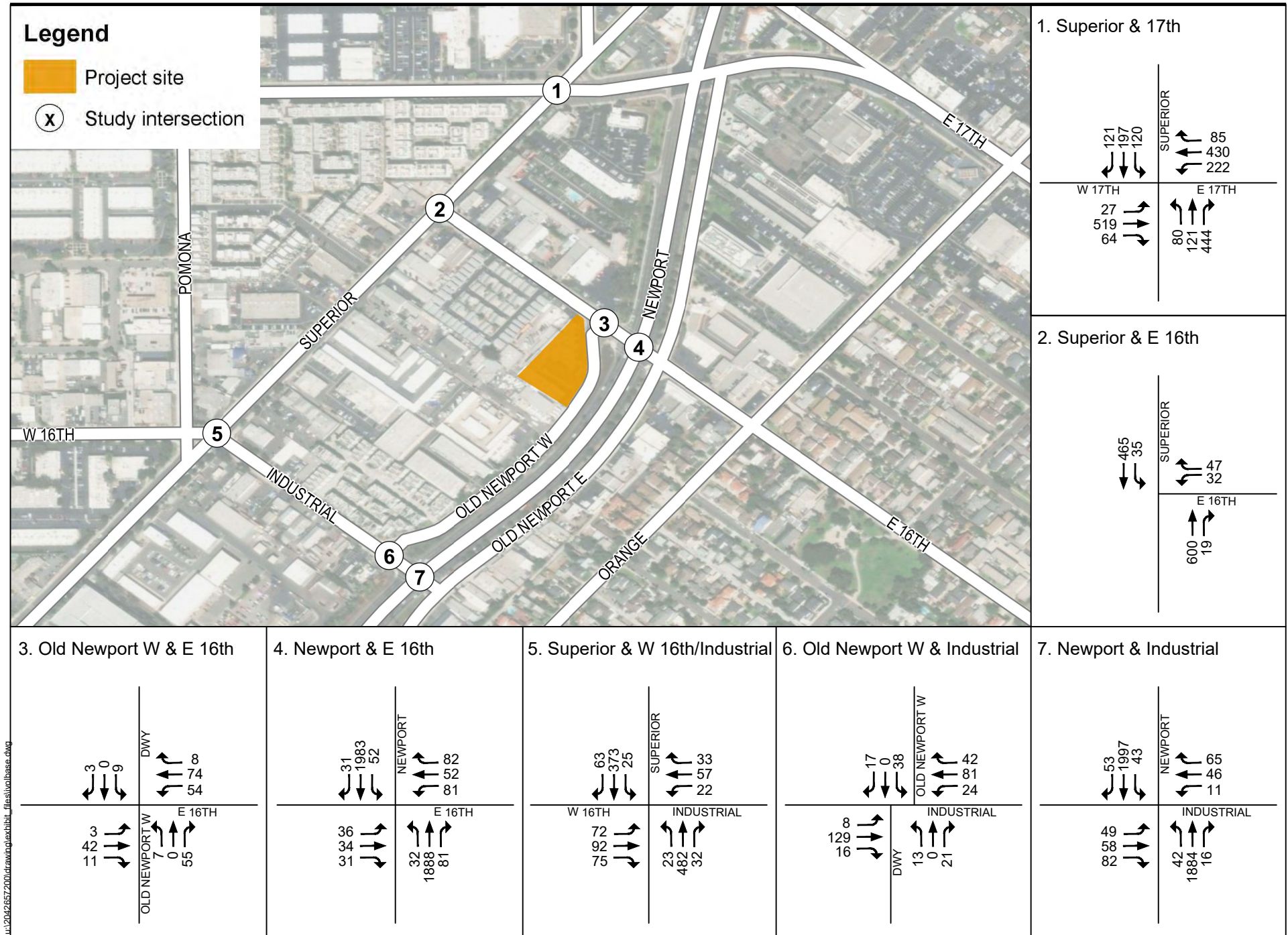

Figure 18

Opening Year (2024) Cumulative Conditions with-Project - PM Peak Hour Volumes - Weekday



\\1120126572001\drawing\exhibit_files\locbase.dwg

Figure 19

Opening Year (2024) Cumulative Conditions with-Project - Mid-Day Peak Hour Volumes - Saturday



2.5 Site Access and Circulation Analysis

Primary access to the Project site would be via one full access driveway on the Old Newport Boulevard frontage road approximately 275 feet south of East 16th Street. A 36' wide driveway is proposed with one inbound lane and one outbound lane. No additional turn-lanes or acceleration/deceleration lanes are proposed or warranted due to the low-speed nature of Old Newport Boulevard. See Figure 20 for the Project driveway peak hour volumes and the proposed lane configuration. LOS analysis for the site access intersection under Opening Year (2024) cumulative conditions is summarized in Table 9. As shown in the table, the site access intersection would operate at LOS A during the weekday mid-day and PM peak hour, as well as during mid-day peak hour on a Saturday.

Table 9 Site Access Driveway LOS Summary – Opening Year (2024) Cumulative Conditions with Project

Location	Weekday				Saturday	
	Mid-Day		PM Peak Hour		Mid-Day	
	Delay	LOS	Delay	LOS	Delay	LOS
Old Newport Blvd & Project Driveway	9.4	A	9.3	A	9.5	A
Note: Cumulative background conditions based on traffic counts collected in February 2023 and OCTAM growth projections. LOS - Level of Service Delay - Delay to driveway exiting vehicles (seconds/vehicle)						

A sidewalk is present on the west side of the Old Newport Boulevard frontage road. There is no sidewalk on the east side of Old Newport Boulevard. There are no designated bicycle facilities in the vicinity of the Project site. The existing accessible curb ramp at the southwest corner of the Old Newport Boulevard/East 16th Street intersection is recommended to be reconstructed to meet current standards for pedestrians crossing Old Newport Boulevard or East 16th Street.

The Orange County Transportation Authority (OCTA) provides local bus service and paratransit services to the area. The Project site is serviced by Route 71 and Route 55 and the nearest bus stop is on Newport Boulevard at the E. 17th Street intersection approximately one-quarter mile north of the Project site.

Pedestrian access to the site would be provided by way of a pathway constructed on-site from the public sidewalk near the Old Newport Boulevard/East 16th Street intersection and extending along the north patio and along the easterly edge of the building to the southerly parking lot. A location for secure bicycle parking on-site is recommended.

On-street parking is allowed on Old Newport Boulevard along the project frontage. On-street parking is not allowed on the northbound side of Old Newport Boulevard opposite of the Project frontage. Sight distance requirements for urban driveways are not based on specific criteria unless signalized per the Caltrans Highway Design Manual (Section 405.1(2)(d)). For the proposed unsignalized driveway, a red curb marking is recommended north and south of the driveway to provide for efficient ingress and egress. Because of the curvature of the roadway, the red curb is recommended for a distance of 100 feet north of the driveway to provide an unobstructed line of sight between the driveway and the start of the road curvature. South of the driveway, red curb is recommended



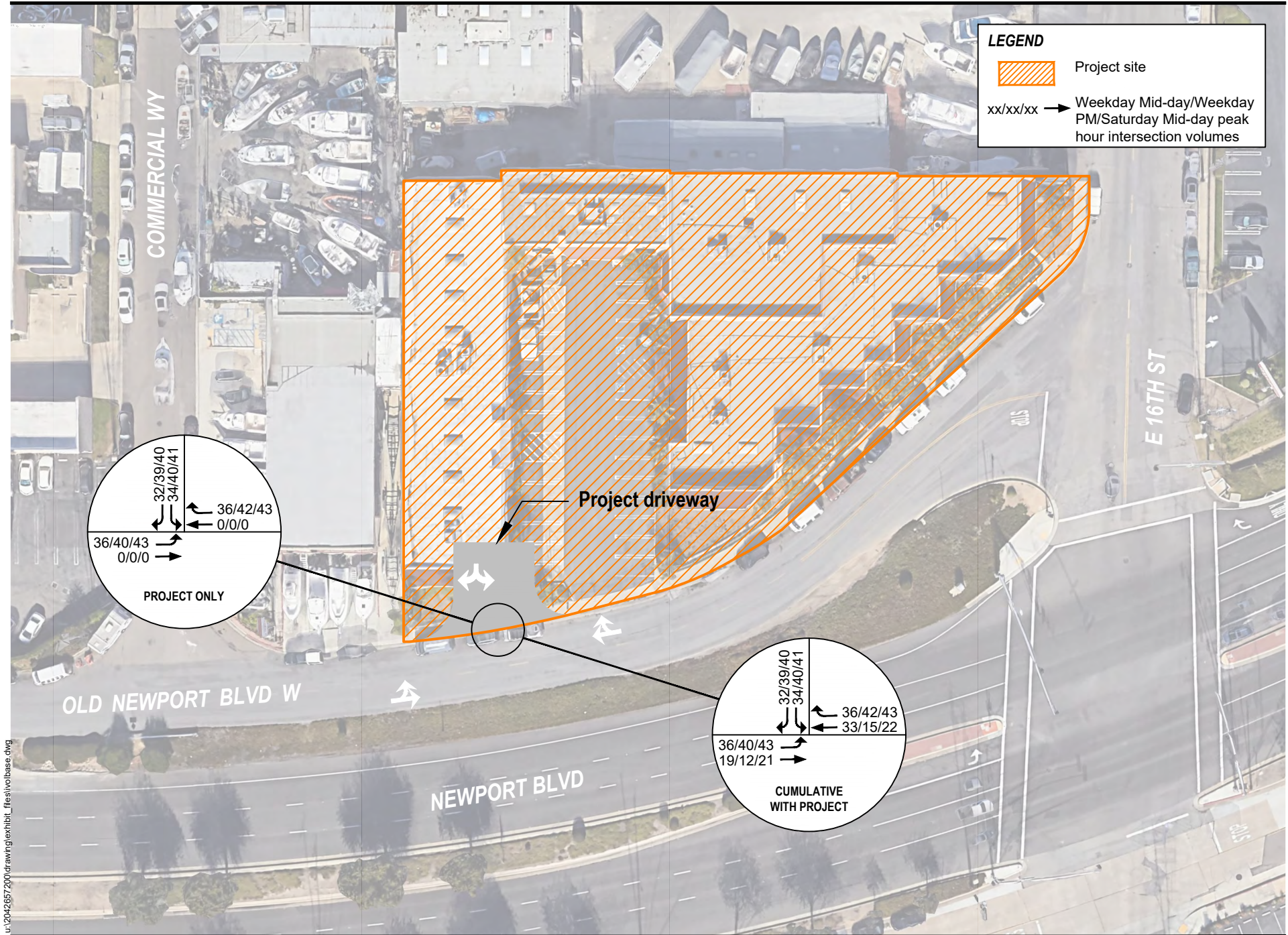

u:\2042657\200\drawing\exhibit_files\vo\base.dwg

Figure 20

-33- Project Driveway Peak Hour Volumes and Lane Configurations

between the driveway and the closest existing driveway at the adjacent parcel (approximately 8 feet). See Section 3 for discussion of on-site parking conditions and Section 4 for analysis of the proposed drive-through lane.

3 Parking Analysis

A parking survey was conducted at the three case study sites to identify the peak parking usage. A professional traffic data collection firm, Transportation Studies Inc. (TSI), was engaged to conduct the parking survey. Parking counts were collected at approximately five-minute intervals over an eight-hour period from 11 AM to 7 PM on a typical weekday (Thursday) and a weekend-day (Saturday) in February 2023. See Appendix D for the parking survey data worksheets. There are a total of 31, 33, and 23 parking spaces at the Costa Mesa, Laguna Hills, and Orange case study sites, respectively.

Based on the data obtained from the three case study site parking surveys and subsequent field reviews, the parking data from the Orange site was determined to be not reflective of actual parking demand since customers appeared to be using parking in the adjacent retail center, and hence is excluded from this study. The parking survey data is summarized in Table 10. During the mid-day peak hour, the average number of vehicles parked on a typical weekday is 19, and on a typical Saturday is 17 vehicles. During the PM peak hour, the average number of vehicles parked on typical weekday is 15, and on a typical Saturday is 17 vehicles. Similarly, the maximum number of vehicles parked on a typical weekday is 29, and on a typical Saturday is 30 vehicles during the mid-day peak hour, whereas during the PM peak hour, the maximum number of vehicles parked on a typical weekday is 27, and on a typical Saturday is 31 vehicles.

Table 10 Case Studies Parking Summary

Location	Mid-Day Peak (11 AM - 3 PM)			PM Peak (3 PM - 7 PM)		
	Average	Max	95th%	Average	Max	95th%
Parked Vehicles - Total Sites						
Thursday	19	29	27	15	27	26
Saturday	17	30	27	17	31	31
Parking Rate per TSF - Total Sites						
Thursday	6.09	10.36	9.80	4.97	9.64	9.39
Saturday	5.46	10.71	9.73	5.46	11.07	11.01

The average and maximum parking rates (per thousand square feet) were derived based on the average and maximum parking demand during a typical weekday and a typical Saturday and the square footage of the case study sites. Based on the consultation with the City staff, this maximum parking rate was utilized to estimate the parking demand for the proposed Project. Table 11 summarizes the required parking during the mid-day and PM peak hour based on the parking rate derived from the case studies. As shown in the table, the proposed Project requires a maximum of 33 parking spaces to meet the expected demand.



Table 11 Required Parking Summary using Case Studies Parking Rate

Proposed Project	Amount	Parking Required	
		Mid-Day Peak	PM Peak
Weekday	3.0 TSF	31	29
Saturday		32	33

Based on the City's parking code, the Project requires 41 parking spaces that includes a 1-space credit for bike racks. However, the Project proposes to provide a total of 34 parking spaces, one additional space than the estimated demand of 33 parking spaces derived from the parking survey data discussed above.

4 Drive-Through Queue Analysis

A queuing analysis of the proposed drive-through has been prepared to establish the typical maximum queue length based on the proposed use. The queuing analysis utilizes data obtained from the three case studies of similar Raising Cane's sites as discussed in the previous sections. Drive-through queue lengths for a typical weekday (Thursday) and a Saturday were collected during the same time periods as the parking counts—five-minute intervals over an eight-hour period from 11 AM to 7 PM in February 2023. See Appendix D for the queuing survey data worksheets.

Table 12 shows the average, maximum and 95th percentile queue summary observed at the three Raising Cane's case study locations. See Figure 22, Figure 23 and Figure 24 for a graphical representation of the queues observed at the three case study locations that show an absolute maximum queue at each of the three case study locations.

Table 12 Case Studies Drive-Through Queue Summary

Location	Mid-Day Peak (11 AM - 3 PM)			PM Peak (3 PM - 7 PM)		
	Average	Max	95th%	Average	Max	95th%
Drive-Through Queues - Total Sites						
Thursday	4	14	9	7	16	13
Saturday	8	17	15	7	15	17
Note: Max represents the average of the three case study sites maximum queue						

As shown in Table 12, on a typical weekday the average drive-through queue length for the case study sites was 4 and 7 vehicles during the mid-day peak and PM peak hour respectively, and the average maximum queue length was 14 and 16 vehicles during the mid-day peak and PM peak hour, respectively. On a Saturday, the average queue length was 8 and 7 vehicles during the mid-day peak and PM peak hour, respectively, and the average maximum queue length was 17 and 15 vehicles during the mid-day peak and PM peak hour, respectively.

Similarly, Table 13 shows the average, maximum and 95th percentile drive-through queue summary observed at the Raising Cane's Costa Mesa case study location. As shown, on a typical weekday the average queue length at the Costa Mesa case study site was 5 and 7 vehicles during the mid-day peak and PM peak hour respectively, and the average maximum queue length was 17 and 18 vehicles during the mid-day peak and PM peak hour, respectively. On a Saturday, the average queue



**Raising Cane's Traffic Study
4 Drive-Through Queue Analysis
October 2023**

length was 10 and 12 vehicles during the mid-day peak and PM peak hour, respectively, and the average maximum queue length was 20 and 21 vehicles during the mid-day peak and PM peak hour, respectively. As shown, the Costa Mesa case study location exhibits slightly longer queue lengths than the average of the three studied locations.

Table 13 Case Study Drive-Through Queue Summary – Costa Mesa Location

Location	Mid-Day Peak (11 AM - 3 PM)			PM Peak (3 PM - 7 PM)		
	Average	Max	95th%	Average	Max	95th%
Thursday	5	17	11	7	18	14
Saturday	10	20	19	12	21	22
Note: Max represents the average of the three case study sites maximum queue						

To be conservative, the Project has been evaluated based on the drive-through queue length data observed at the Costa Mesa case study site. Therefore, the maximum Project drive-through queue during weekday mid-day conditions is assumed to be 17 vehicles, and 18 vehicles during the PM peak hour. Similarly, the maximum queue during Saturday mid-day is assumed to be 20 vehicles and during the PM peak hour is assumed to be 21 vehicles.

Access to the Project site would be via one full access driveway on the Old Newport Boulevard frontage road. The proposed site plan shows a queuing storage capacity of up to 18 vehicles within the two drive-through lanes. The lane that is adjacent to the pickup window is long enough for 14 cars to queue from the start of the drive-through lane to the pickup window and there is additional space for 4 cars in the second lane, for a total queue capacity of 18 cars. Raising Canes would be responsible for managing the drive-through lane to achieve the maximum capacity of 18 cars. Based on the Costa Mesa case study queuing data, which shows maximum queues in the range of 17 to 21 vehicles during weekday and Saturday peak hours, the proposed Project's vehicle maximum queue would exceed the capacity of two proposed drive-through lanes. If the vehicle queue extends longer than the 18-vehicle capacity of the drive-through lane, the queue would block some of the on-site parking spaces. The proposed site plan indicates that approximately 5 additional vehicles could queue on-site before spilling over onto the sidewalk, for a total of 23 vehicles accommodated on-site.



Figure 21 Weekday Mid-Day Queue Data at the Raising Cane's Case Study Locations

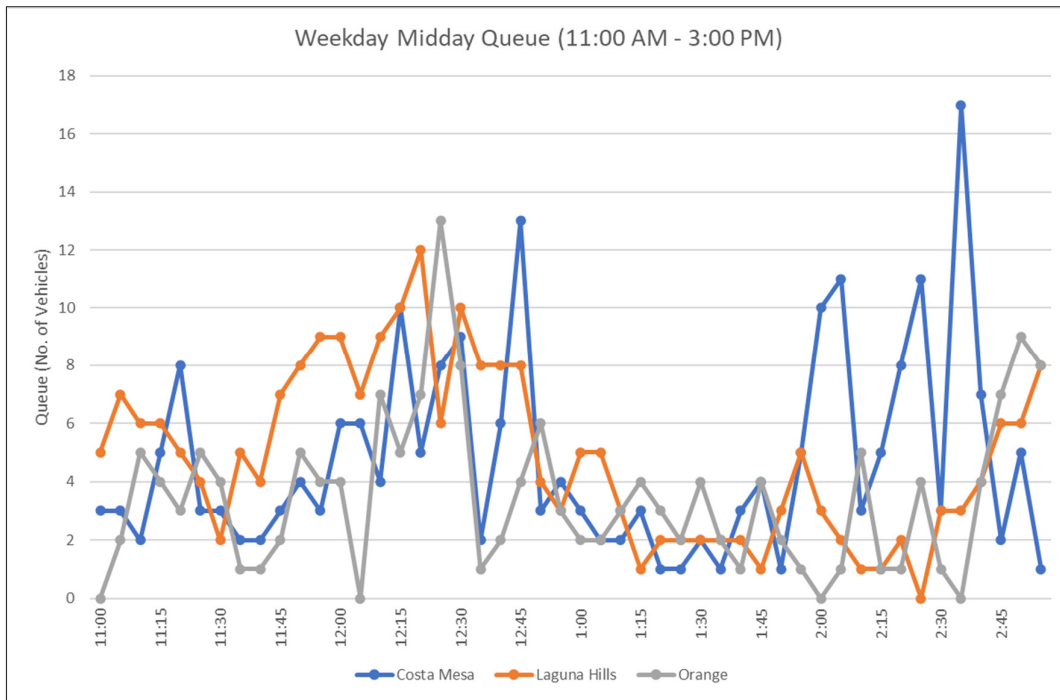

Figure 22 Weekday PM Queue Data at the Raising Cane's Case Study Locations

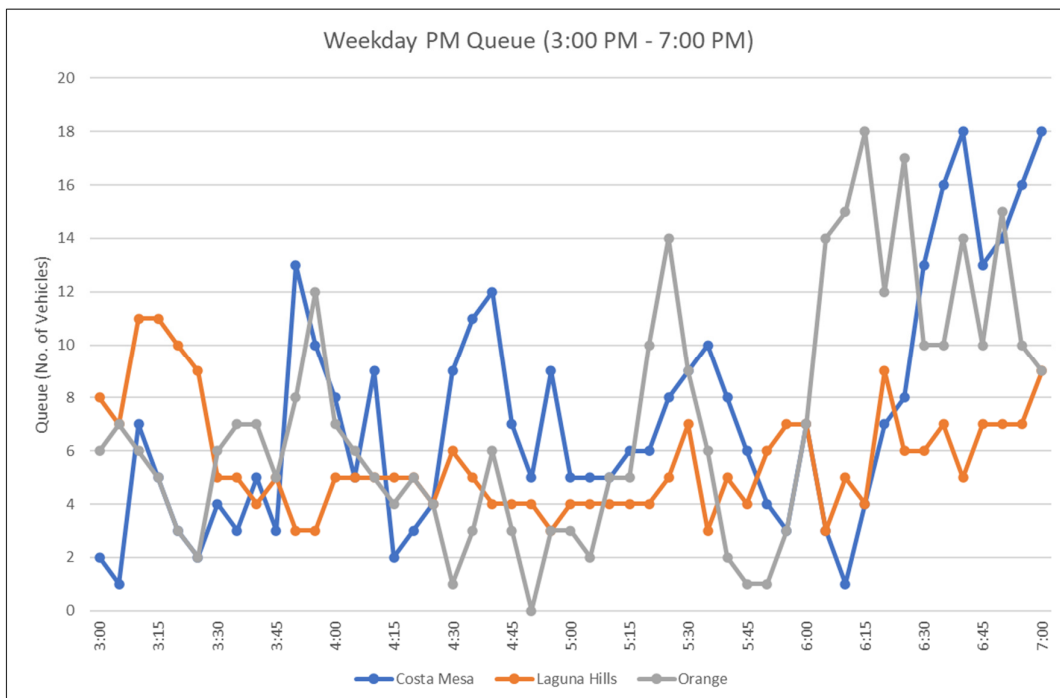

Figure 23 Weekend Mid-Day Queue Data at the Raising Cane's Case Study Locations

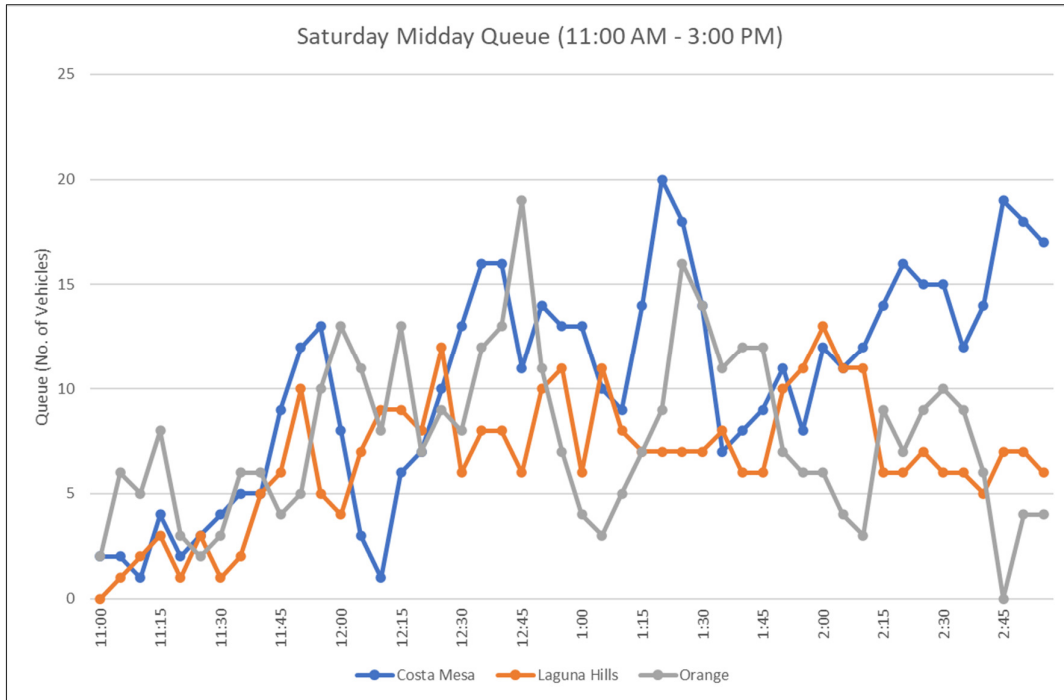
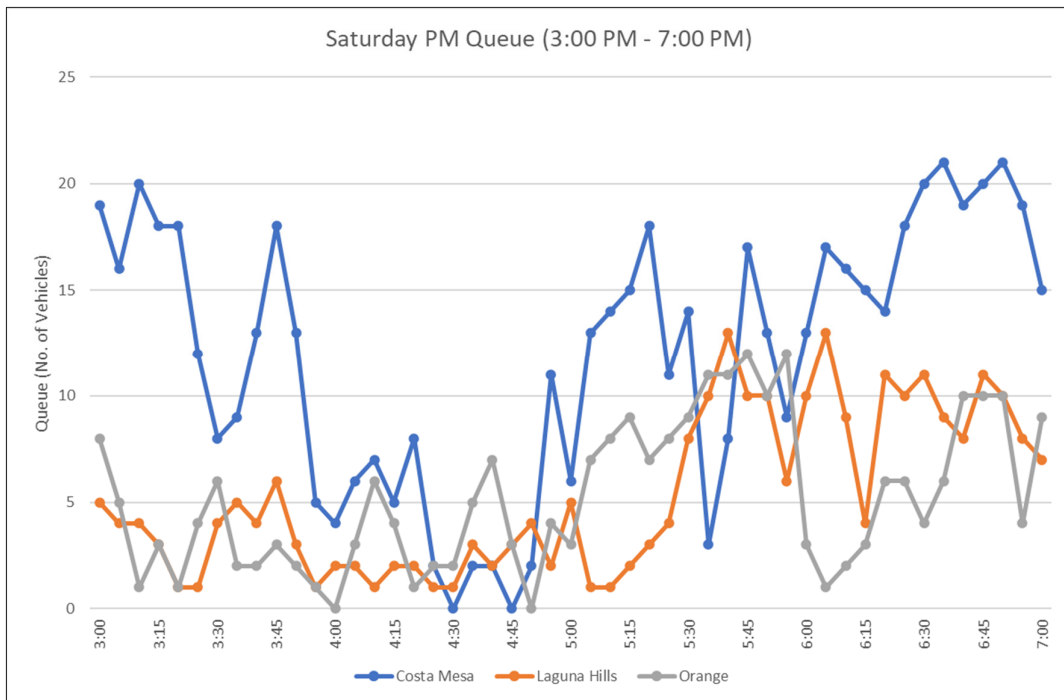

Figure 24 Weekend PM Queue Data at the Raising Cane's Case Study Locations



5 Conclusion

This traffic analysis was prepared to evaluate the Project's effect on traffic conditions in accordance with the City's traffic analysis procedures. The Project was evaluated under opening day conditions with the proposed Project. Based on the results of the LOS analyses and the criteria set forth by the City, the study intersections would not exceed the City's acceptable threshold of LOS D during the weekday mid-day, weekday PM, or Saturday mid-day peak hours. The project's driveway onto the Old Newport Boulevard frontage road would operate at LOS A during each peak hour.

Two ADA compliant ramps at the southwest corner of the Old Newport Boulevard/East 16th Street intersection are recommended and a potential crosswalk may be required to meet current standards for pedestrians crossing Old Newport Boulevard or East 16th Street. For the proposed unsignalized driveway, a red curb marking is recommended north and south of the driveway to provide for efficient ingress and egress. Because of the curvature of the roadway, the red curb is recommended for a distance of 100 feet north of the driveway to provide an unobstructed line of sight between the driveway and the start of the road curvature. South of the driveway, red curb is recommended between the driveway and the closest existing driveway at the adjacent parcel (approximately 8 feet).

A parking analysis was also conducted to determine the maximum parking demand and if the parking provided by the proposed site plan is adequate. The study determined that the proposed parking lot is providing one additional space more than the maximum parking demand determined from the case studies.

A queuing analysis for the proposed drive-through was also conducted to establish the typical maximum queue length based on case study data. The study determined that the proposed drive-through lanes would not accommodate the maximum anticipated queue length determined from the Raising Cane's case study location in Costa Mesa. If the vehicle queue extends longer than the 18-vehicle capacity of the drive-through lane, the queue would block some of the on-site parking spaces. The proposed site plan indicates that approximately 5 additional vehicles could queue on-site before spilling over onto the sidewalk, for a total of 23 vehicles accommodated on-site.



Appendix A DRIVEWAY ENTER AND EXIT TRAFFIC VOLUME DATA SHEETS



TRANSPORTATION STUDIES, INC.

File D2302032
 Location Costa Mesa Raising Cane's Driveway
 Date 02-09-2023
 City: Costa Mesa

	In	Out	Hour Total			
	In	Out	In	Out	Total	
11:00 AM	18	12	70	66	136	
11:15 AM	15	18	79	72	151	
11:30 AM	18	14	89	77	166	
11:45 AM	19	22	100	91	191	Mid-Day Max
12:00 PM	27	18	91	86	177	
12:15 PM	25	23	84	87	171	
12:30 PM	29	28	71	83	154	
12:45 PM	10	17	52	70	122	
1:00 PM	20	19	67	64	131	
1:15 PM	12	19	69	70	139	
1:30 PM	10	15	75	67	142	
1:45 PM	25	11	87	78	165	
2:00 PM	22	25	80	86	166	
2:15 PM	18	16	76	75	151	
2:30 PM	22	26	71	82	153	
2:45 PM	18	19	68	74	142	
3:00 PM	18	14	68	69	137	
3:15 PM	13	23	69	75	144	
3:30 PM	19	18	80	71	151	
3:45 PM	18	14	78	72	150	
4:00 PM	19	20	71	74	145	
4:15 PM	24	19	71	74	145	
4:30 PM	17	19	65	69	134	
4:45 PM	11	16	66	64	130	
5:00 PM	19	20	76	72	148	
5:15 PM	18	14	76	71	147	
5:30 PM	18	14	86	76	162	
5:45 PM	21	24	100	89	189	PM Max
6:00 PM	19	19	101	84	185	
6:15 PM	28	19				
6:30 PM	32	27				
6:45 PM	22	19				
TOTAL	624	601				

TRANSPORTATION STUDIES, INC.

File D2302033
 Location Costa Mesa Raising Cane's Driveway
 Date 02-11-2023
 City: Costa Mesa

	In	Out	Hour Total			
			In	Out	Total	
11:00 AM	18	14	71	57	128	
11:15 AM	16	6	71	60	131	
11:30 AM	18	15	84	73	157	
11:45 AM	19	22	95	86	181	
12:00 PM	18	17	108	96	204	
12:15 PM	29	19	115	102	217	
12:30 PM	29	28	111	108	219	Mid-Day Max
12:45 PM	32	32	102	106	208	
1:00 PM	25	23	91	92	183	
1:15 PM	25	25	91	94	185	
1:30 PM	20	26	83	86	169	
1:45 PM	21	18	97	81	178	
2:00 PM	25	25	95	87	182	
2:15 PM	17	17	88	82	170	
2:30 PM	34	21	83	87	170	
2:45 PM	19	24	70	75	145	
3:00 PM	18	20	70	83	153	
3:15 PM	12	22	81	84	165	
3:30 PM	21	9	86	82	168	
3:45 PM	19	32	76	84	160	
4:00 PM	29	21	82	68	150	
4:15 PM	17	20	73	70	143	
4:30 PM	11	11	78	70	148	
4:45 PM	25	16	90	79	169	
5:00 PM	20	23	99	92	191	
5:15 PM	22	20	112	96	208	
5:30 PM	23	20	124	100	224	
5:45 PM	34	29	126	99	225	PM Max
6:00 PM	33	27	105	92	197	
6:15 PM	34	24				
6:30 PM	25	19				
6:45 PM	13	22				
TOTAL	721	667				

TRANSPORTATION STUDIES, INC.

File D2302034
 Location Laguna Hills Raising Cane's Driveway
 Date 02-09-2023
 City: Laguna Hills

	In	Out	Hour Total			
			In	Out	Total	
11:00 AM	0	7	1	25	26	
11:15 AM	0	7	1	27	28	
11:30 AM	1	4	2	31	33	
11:45 AM	0	7	1	38	39	
12:00 PM	0	9	1	44	45	
12:15 PM	1	11	1	47	48	Mid-Day Max
12:30 PM	0	11	0	45	45	
12:45 PM	0	13	0	39	39	
1:00 PM	0	12	0	33	33	
1:15 PM	0	9	0	29	29	
1:30 PM	0	5	0	21	21	
1:45 PM	0	7	0	19	19	
2:00 PM	0	8	0	19	19	
2:15 PM	0	1	0	21	21	
2:30 PM	0	3	1	28	29	
2:45 PM	0	7	1	35	36	
3:00 PM	0	10	3	33	36	
3:15 PM	1	8	3	38	41	PM Max
3:30 PM	0	10	2	37	39	
3:45 PM	2	5	2	34	36	
4:00 PM	0	15	0	37	37	
4:15 PM	0	7	0	30	30	
4:30 PM	0	7	0	30	30	
4:45 PM	0	8	0	32	32	
5:00 PM	0	8	0	32	32	
5:15 PM	0	7	0	33	33	
5:30 PM	0	9	0	31	31	
5:45 PM	0	8	0	33	33	
6:00 PM	0	9	0	30	30	
6:15 PM	0	5				
6:30 PM	0	11				
6:45 PM	0	5				
TOTAL	5	253				

TRANSPORTATION STUDIES, INC.

File D2302035
 Location Laguna Hills Raising Cane's Driveway
 Date 02-11-2023
 City: Laguna Hills

	In	Out	Hour Total			
			In	Out	Total	
11:00 AM	0	3	0	25	25	
11:15 AM	0	8	0	30	30	
11:30 AM	0	3	0	33	33	
11:45 AM	0	11	0	42	42	
12:00 PM	0	8	0	45	45	
12:15 PM	0	11	0	49	49	
12:30 PM	0	12	0	53	53	Mid-Day Max
12:45 PM	0	14	0	47	47	
1:00 PM	0	12	0	41	41	
1:15 PM	0	15	0	36	36	
1:30 PM	0	6	0	32	32	
1:45 PM	0	8	0	30	30	
2:00 PM	0	7	0	29	29	
2:15 PM	0	11	0	27	27	
2:30 PM	0	4	1	24	25	
2:45 PM	0	7	1	26	27	
3:00 PM	0	5	2	20	22	
3:15 PM	1	8	2	20	22	
3:30 PM	0	6	1	17	18	
3:45 PM	1	1	1	18	19	
4:00 PM	0	5	0	22	22	
4:15 PM	0	5	2	22	24	
4:30 PM	0	7	2	20	22	
4:45 PM	0	5	2	21	23	
5:00 PM	2	5	3	27	30	
5:15 PM	0	3	1	34	35	
5:30 PM	0	8	1	41	42	
5:45 PM	1	11	1	46	47	PM Max
6:00 PM	0	12	0	44	44	
6:15 PM	0	10				
6:30 PM	0	13				
6:45 PM	0	9				
TOTAL	5	253				

TRANSPORTATION STUDIES, INC.

File D2302036
 Location Orange Raising Cane's Driveway
 Date 02-09-2023
 City: Orange

	South Dwy		North Dwy		Hour Total			
	In	Out	In	Out	In	Out	Total	
11:00 AM	7	5	0	6	53	57	110	
11:15 AM	13	4	2	12	69	64	133	
11:30 AM	12	7	0	13	73	71	144	
11:45 AM	19	8	0	14	76	71	147	Mid-Day Max
12:00 PM	22	7	1	12	73	70	143	
12:15 PM	19	6	0	18	67	69	136	
12:30 PM	14	12	1	10	64	66	130	
12:45 PM	14	6	2	14	59	63	122	
1:00 PM	17	12	0	9	50	60	110	
1:15 PM	15	6	1	15	40	55	95	
1:30 PM	9	12	1	7	33	47	80	
1:45 PM	7	8	0	10	43	44	87	
2:00 PM	7	9	0	5	54	53	107	
2:15 PM	9	7	0	7	68	61	129	
2:30 PM	19	3	1	8	71	68	139	
2:45 PM	18	7	0	20	62	76	138	
3:00 PM	19	9	2	13	66	75	141	
3:15 PM	12	8	0	13	55	72	127	
3:30 PM	10	5	1	15	55	68	123	
3:45 PM	20	7	2	19	59	66	125	
4:00 PM	10	6	0	12	53	58	111	
4:15 PM	11	7	1	9	60	60	120	
4:30 PM	15	5	0	13	68	62	130	
4:45 PM	15	7	1	11	63	66	129	
5:00 PM	14	12	3	11	71	68	139	
5:15 PM	19	6	1	12	82	70	152	
5:30 PM	9	9	1	15	80	85	165	
5:45 PM	22	11	2	11	99	94	193	
6:00 PM	28	6	0	16	99	103	202	PM Max
6:15 PM	17	18	1	21				
6:30 PM	29	11	0	23				
6:45 PM	24	15	0	18				
TOTAL	495	261	24	412				

TRANSPORTATION STUDIES, INC.

File D2302037
 Location Orange Raising Cane's Driveway
 Date 02-11-2023
 City: Orange

	South Dwy		North Dwy		Hour Total			
	In	Out	In	Out	In	Out	Total	
11:00 AM	7	6	0	6	62	52	114	
11:15 AM	9	3	0	12	74	64	138	
11:30 AM	15	2	0	10	87	72	159	
11:45 AM	31	4	2	16	99	89	188	Mid-Day Max
12:00 PM	19	11	0	16	81	97	178	
12:15 PM	22	7	0	18	76	95	171	
12:30 PM	27	11	0	22	80	87	167	
12:45 PM	13	3	1	25	74	86	160	
1:00 PM	14	8	1	15	77	78	155	
1:15 PM	26	5	2	11	82	80	162	
1:30 PM	21	9	0	22	74	82	156	
1:45 PM	16	9	2	14	63	75	138	
2:00 PM	19	10	0	16	65	77	142	
2:15 PM	18	6	0	13	60	77	137	
2:30 PM	10	11	0	14	58	74	132	
2:45 PM	18	10	0	15	61	66	127	
3:00 PM	14	12	2	15	59	65	124	
3:15 PM	16	5	1	11	57	57	114	
3:30 PM	13	3	2	10	53	60	113	
3:45 PM	16	13	1	12	56	62	118	
4:00 PM	12	9	1	9	57	61	118	
4:15 PM	12	6	0	13	66	67	133	
4:30 PM	16	5	0	11	66	66	132	
4:45 PM	17	9	1	13	68	68	136	
5:00 PM	21	8	0	16	67	75	142	
5:15 PM	12	7	2	11	57	70	127	
5:30 PM	18	9	0	11	63	73	136	
5:45 PM	16	7	1	21	67	75	142	
6:00 PM	11	7	0	12	72	70	142	PM Max
6:15 PM	18	10	1	12				
6:30 PM	22	5	1	15				
6:45 PM	21	9	0	15				
TOTAL	540	239	21	452				

Appendix B TRAFFIC COUNT DATA SHEETS



City: COSTA MESA
 N-S Direction: SUPERIOR AVENUE
 E-W Direction: W. 17TH STREET

File Name : H2302012
 Site Code : 00000000
 Start Date : 2/2/2023
 Page No : 1

Groups Printed- Turning Movement Count

Start Time	SUPERIOR AVENUE Southbound				W 17TH ST Westbound				SUPERIOR AVENUE Northbound				W 17TH ST Eastbound				Int. Total
	Right	Thru	Left	U Turns	Right	Thru	Left	U Turns	Right	Thru	Left	U Turns	Right	Thru	Left	U Turns	
11:00	30	74	20	0	17	86	58	1	126	40	21	0	14	113	7	0	607
11:15	18	81	23	0	16	105	57	0	141	40	20	0	10	97	13	0	621
11:30	29	96	29	0	9	95	60	0	129	37	16	0	10	121	10	0	641
11:45	24	74	23	0	19	118	43	3	144	34	31	0	16	153	12	0	694
Total	101	325	95	0	61	404	218	4	540	151	88	0	50	484	42	0	2563
12:00	34	68	24	0	20	110	48	0	137	45	27	0	16	147	15	0	691
12:15	23	95	24	0	17	119	65	0	121	39	23	0	18	136	10	0	690
12:30	17	79	30	0	16	110	57	0	121	38	28	0	23	149	16	0	684
12:45	34	110	22	0	11	110	78	2	139	38	16	0	16	107	8	0	691
Total	108	352	100	0	64	449	248	2	518	160	94	0	73	539	49	0	2756
17:00	26	89	20	0	16	112	65	0	168	48	22	0	18	127	8	0	719
17:15	21	86	16	0	18	101	45	0	137	46	33	0	17	109	13	0	642
17:30	34	68	15	0	14	116	52	1	128	28	27	0	22	142	5	0	652
17:45	29	59	21	0	17	100	74	0	117	30	25	0	9	135	9	0	625
Total	110	302	72	0	65	429	236	1	550	152	107	0	66	513	35	0	2638
18:00	27	67	32	0	13	88	64	0	120	33	16	0	13	107	13	0	593
18:15	27	67	20	0	17	83	67	1	113	19	12	0	11	109	4	0	550
18:30	22	47	28	0	13	91	65	1	88	19	17	0	13	115	9	0	528
18:45	24	48	20	0	12	95	52	1	80	20	14	0	13	95	3	0	477
Total	100	229	100	0	55	357	248	3	401	91	59	0	50	426	29	0	2148
Grand Total	419	1208	367	0	245	1639	950	10	2009	554	348	0	239	1962	155	0	10105
Apprch %	21	60.6	18.4	0	8.6	57.6	33.4	0.4	69	19	12	0	10.1	83.3	6.6	0	
Total %	4.1	12	3.6	0	2.4	16.2	9.4	0.1	19.9	5.5	3.4	0	2.4	19.4	1.5	0	

City: COSTA MESA
 N-S Direction: SUPERIOR AVENUE
 E-W Direction: W. 17TH STREET

File Name : H2302012
 Site Code : 00000000
 Start Date : 2/2/2023
 Page No : 2

Start Time	SUPERIOR AVENUE Southbound					W 17TH ST Westbound					SUPERIOR AVENUE Northbound					W 17TH ST Eastbound					Int. Total
	Right	Thru	Left	U Turns	App. Total	Right	Thru	Left	U Turns	App. Total	Right	Thru	Left	U Turns	App. Total	Right	Thru	Left	U Turns	App. Total	
Peak Hour Analysis From 11:00 to 12:45 - Peak 1 of 1																					
Peak Hour for Entire Intersection Begins at 11:45																					
11:45	24	74	23	0	121	19	118	43	3	183	144	34	31	0	209	16	153	12	0	181	694
12:00	34	68	24	0	126	20	110	48	0	178	137	45	27	0	209	16	147	15	0	178	691
12:15	23	95	24	0	142	17	119	65	0	201	121	39	23	0	183	18	136	10	0	164	690
12:30	17	79	30	0	126	16	110	57	0	183	121	38	28	0	187	23	149	16	0	188	684
Total Volume	98	316	101	0	515	72	457	213	3	745	523	156	109	0	788	73	585	53	0	711	2759
% App. Total	19	61.4	19.6	0		9.7	61.3	28.6	0.4		66.4	19.8	13.8	0		10.3	82.3	7.5	0		
PHF	.721	.832	.842	.000	.907	.900	.960	.819	.250	.927	.908	.867	.879	.000	.943	.793	.956	.828	.000	.945	.994

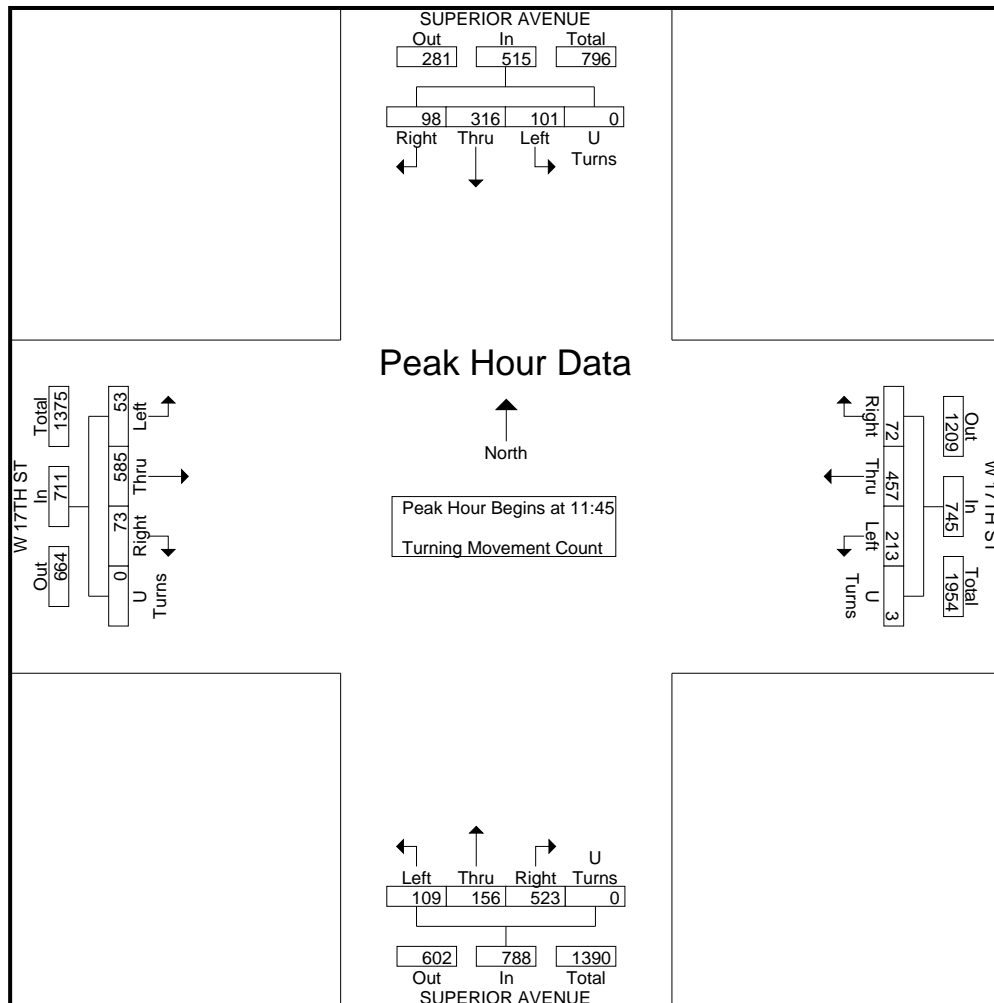

City: COSTA MESA
 N-S Direction: SUPERIOR AVENUE
 E-W Direction: W. 17TH STREET

File Name : H2302012
 Site Code : 00000000
 Start Date : 2/2/2023
 Page No : 3

Start Time	SUPERIOR AVENUE Southbound					W 17TH ST Westbound					SUPERIOR AVENUE Northbound					W 17TH ST Eastbound					Int. Total
	Right	Thru	Left	U Turns	App. Total	Right	Thru	Left	U Turns	App. Total	Right	Thru	Left	U Turns	App. Total	Right	Thru	Left	U Turns	App. Total	
Peak Hour Analysis From 17:00 to 18:45 - Peak 1 of 1																					
Peak Hour for Entire Intersection Begins at 17:00																					
17:00	26	89	20	0	135	16	112	65	0	193	168	48	22	0	238	18	127	8	0	153	719
17:15	21	86	16	0	123	18	101	45	0	164	137	46	33	0	216	17	109	13	0	139	642
17:30	34	68	15	0	117	14	116	52	1	183	128	28	27	0	183	22	142	5	0	169	652
17:45	29	59	21	0	109	17	100	74	0	191	117	30	25	0	172	9	135	9	0	153	625
Total Volume	110	302	72	0	484	65	429	236	1	731	550	152	107	0	809	66	513	35	0	614	2638
% App. Total	22.7	62.4	14.9	0		8.9	58.7	32.3	0.1		68	18.8	13.2	0		10.7	83.6	5.7	0		
PHF	.809	.848	.857	.000	.896	.903	.925	.797	.250	.947	.818	.792	.811	.000	.850	.750	.903	.673	.000	.908	.917

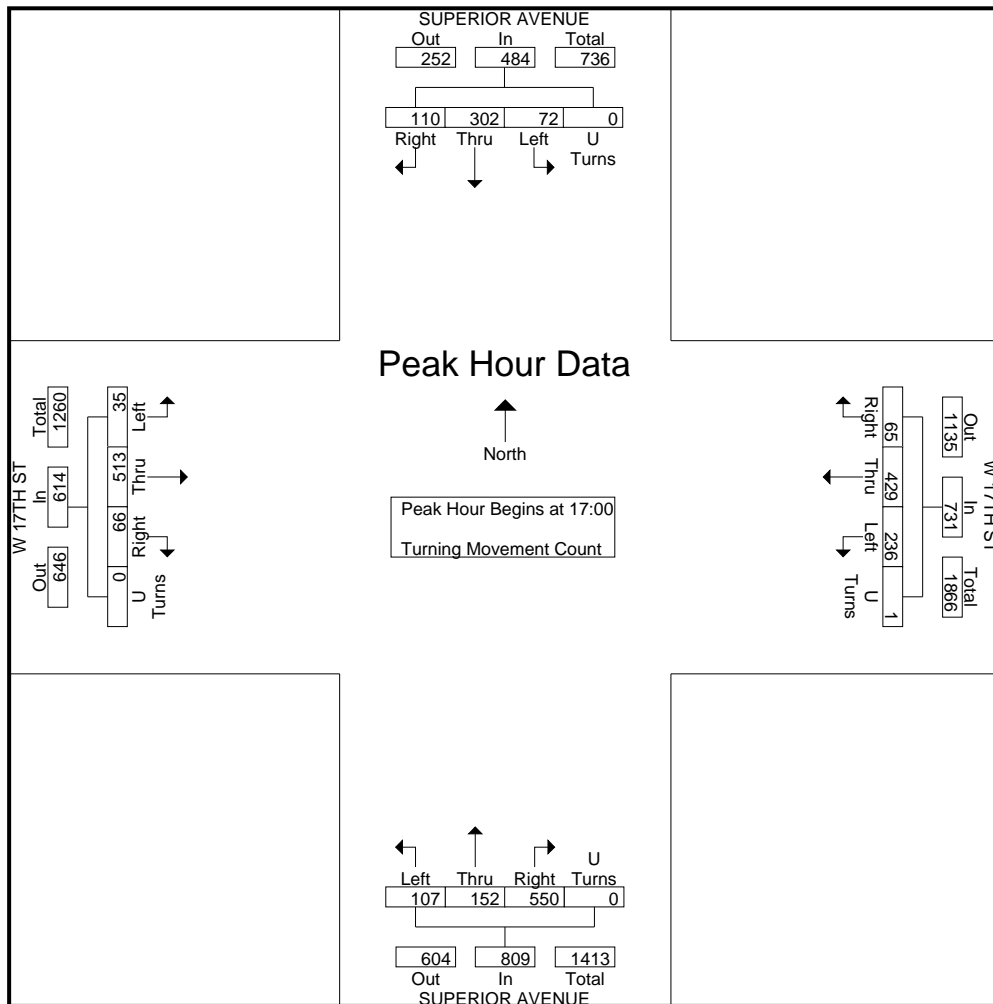

City: COSTA MESA
 N-S Direction: SUPERIOR AVENUE
 E-W Direction: E. 16TH STREET

File Name : H2302010
 Site Code : 00000000
 Start Date : 2/2/2023
 Page No : 1

Groups Printed- Turning Movement Count

Start Time	SUPERIOR AVENUE Southbound				E. 16TH STREET Westbound				SUPERIOR AVENUE Northbound				DEAD END Eastbound				Int. Total	
	Right	Thru	Left	U Turns	Right	Thru	Left	U Turns	Right	Thru	Left	U Turns	Right	Thru	Left	U Turns		
11:00	0	153	5	1	5	0	5	0	3	176	0	0	0	0	0	0	0	348
11:15	0	142	3	0	11	0	7	0	4	197	0	1	0	0	0	0	0	365
11:30	0	159	5	1	7	0	7	0	7	176	0	0	0	0	0	0	0	362
11:45	0	136	12	0	7	0	6	0	6	170	0	0	0	0	0	0	0	337
Total	0	590	25	2	30	0	25	0	20	719	0	1	0	0	0	0	0	1412
12:00	0	121	13	1	9	0	6	0	5	210	0	0	0	0	0	0	0	365
12:15	0	169	13	1	19	0	11	0	2	169	0	0	0	0	0	0	0	384
12:30	0	172	12	1	10	0	9	0	5	180	0	0	0	0	0	0	0	389
12:45	0	181	10	1	9	0	8	0	6	162	0	0	0	0	0	0	0	377
Total	0	643	48	4	47	0	34	0	18	721	0	0	0	0	0	0	0	1515
17:00	0	163	7	0	9	0	7	0	4	237	0	0	0	0	0	0	0	427
17:15	0	134	9	0	12	0	9	0	3	179	0	0	0	0	0	0	0	346
17:30	0	137	6	2	13	0	2	0	3	194	0	0	0	0	0	0	0	357
17:45	0	145	2	0	6	0	4	0	5	142	0	0	0	0	0	0	0	304
Total	0	579	24	2	40	0	22	0	15	752	0	0	0	0	0	0	0	1434
18:00	0	130	7	0	16	0	12	0	2	160	0	0	0	0	0	0	0	327
18:15	0	142	6	0	8	0	5	0	3	120	0	0	0	0	0	0	0	284
18:30	0	102	8	0	4	0	4	0	4	115	0	0	0	0	0	0	0	237
18:45	0	104	7	0	7	0	7	0	8	87	0	0	0	0	0	0	0	220
Total	0	478	28	0	35	0	28	0	17	482	0	0	0	0	0	0	0	1068
Grand Total	0	2290	125	8	152	0	109	0	70	2674	0	1	0	0	0	0	0	5429
Apprch %	0	94.5	5.2	0.3	58.2	0	41.8	0	2.6	97.4	0	0	0	0	0	0	0	
Total %	0	42.2	2.3	0.1	2.8	0	2	0	1.3	49.3	0	0	0	0	0	0	0	

City: COSTA MESA
 N-S Direction: SUPERIOR AVENUE
 E-W Direction: E. 16TH STREET

File Name : H2302010
 Site Code : 00000000
 Start Date : 2/2/2023
 Page No : 2

Start Time	SUPERIOR AVENUE Southbound					E. 16TH STREET Westbound					SUPERIOR AVENUE Northbound					DEAD END Eastbound					Int. Total
	Right	Thru	Left	U Turns	App. Total	Right	Thru	Left	U Turns	App. Total	Right	Thru	Left	U Turns	App. Total	Right	Thru	Left	U Turns	App. Total	
Peak Hour Analysis From 11:00 to 12:45 - Peak 1 of 1																					
Peak Hour for Entire Intersection Begins at 12:00																					
12:00	0	121	13	1	135	9	0	6	0	15	5	210	0	0	215	0	0	0	0	0	365
12:15	0	169	13	1	183	19	0	11	0	30	2	169	0	0	171	0	0	0	0	0	384
12:30	0	172	12	1	185	10	0	9	0	19	5	180	0	0	185	0	0	0	0	0	389
12:45	0	181	10	1	192	9	0	8	0	17	6	162	0	0	168	0	0	0	0	0	377
Total Volume	0	643	48	4	695	47	0	34	0	81	18	721	0	0	739	0	0	0	0	0	1515
% App. Total	0	92.5	6.9	0.6		58	0	42	0		2.4	97.6	0	0		0	0	0	0		
PHF	.000	.888	.923	1.00	.905	.618	.000	.773	.000	.675	.750	.858	.000	.000	.859	.000	.000	.000	.000	.000	.974

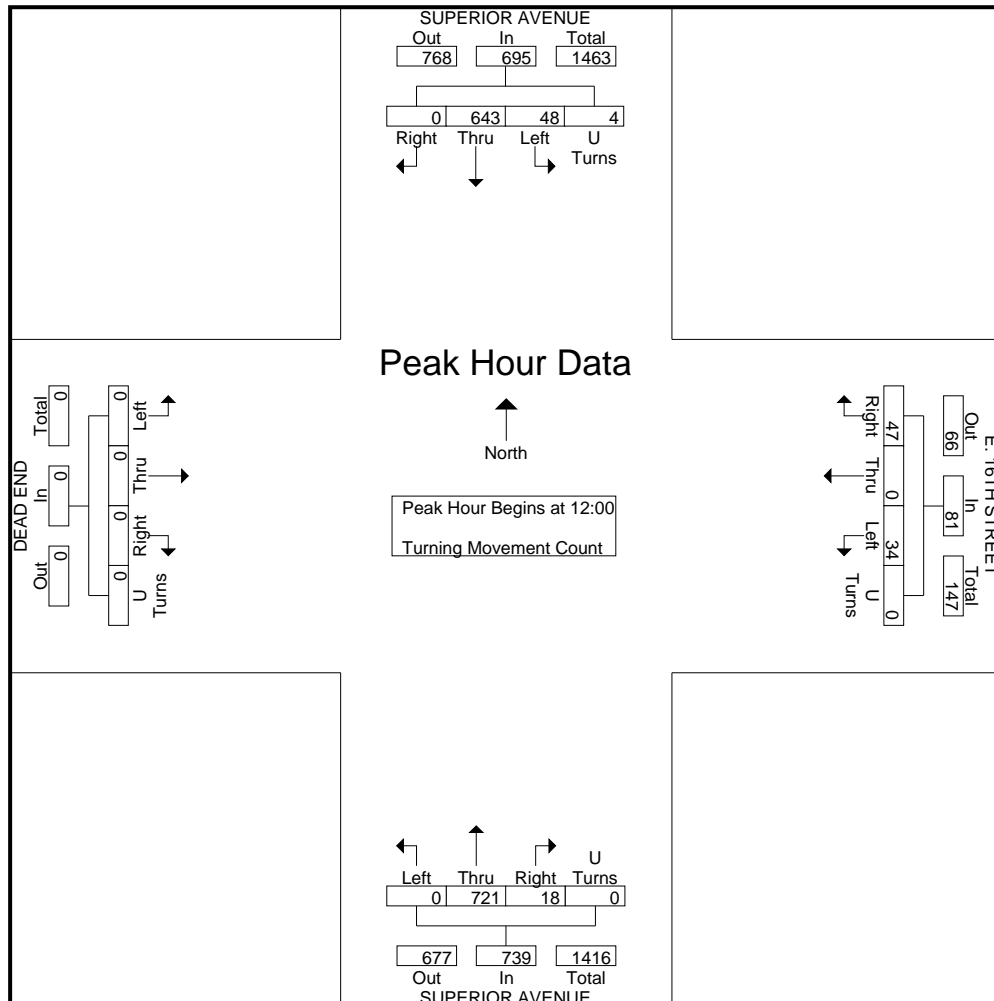

City: COSTA MESA
 N-S Direction: SUPERIOR AVENUE
 E-W Direction: E. 16TH STREET

File Name : H2302010
 Site Code : 00000000
 Start Date : 2/2/2023
 Page No : 3

Start Time	SUPERIOR AVENUE Southbound					E. 16TH STREET Westbound					SUPERIOR AVENUE Northbound					DEAD END Eastbound					Int. Total
	Right	Thru	Left	U Turns	App. Total	Right	Thru	Left	U Turns	App. Total	Right	Thru	Left	U Turns	App. Total	Right	Thru	Left	U Turns	App. Total	
Peak Hour Analysis From 17:00 to 18:45 - Peak 1 of 1																					
Peak Hour for Entire Intersection Begins at 17:00																					
17:00	0	163	7	0	170	9	0	7	0	16	4	237	0	0	241	0	0	0	0	0	427
17:15	0	134	9	0	143	12	0	9	0	21	3	179	0	0	182	0	0	0	0	0	346
17:30	0	137	6	2	145	13	0	2	0	15	3	194	0	0	197	0	0	0	0	0	357
17:45	0	145	2	0	147	6	0	4	0	10	5	142	0	0	147	0	0	0	0	0	304
Total Volume	0	579	24	2	605	40	0	22	0	62	15	752	0	0	767	0	0	0	0	0	1434
% App. Total	0	95.7	4	0.3		64.5	0	35.5	0		2	98	0	0		0	0	0	0	0	
PHF	.000	.888	.667	.250	.890	.769	.000	.611	.000	.738	.750	.793	.000	.000	.796	.000	.000	.000	.000	.000	.840

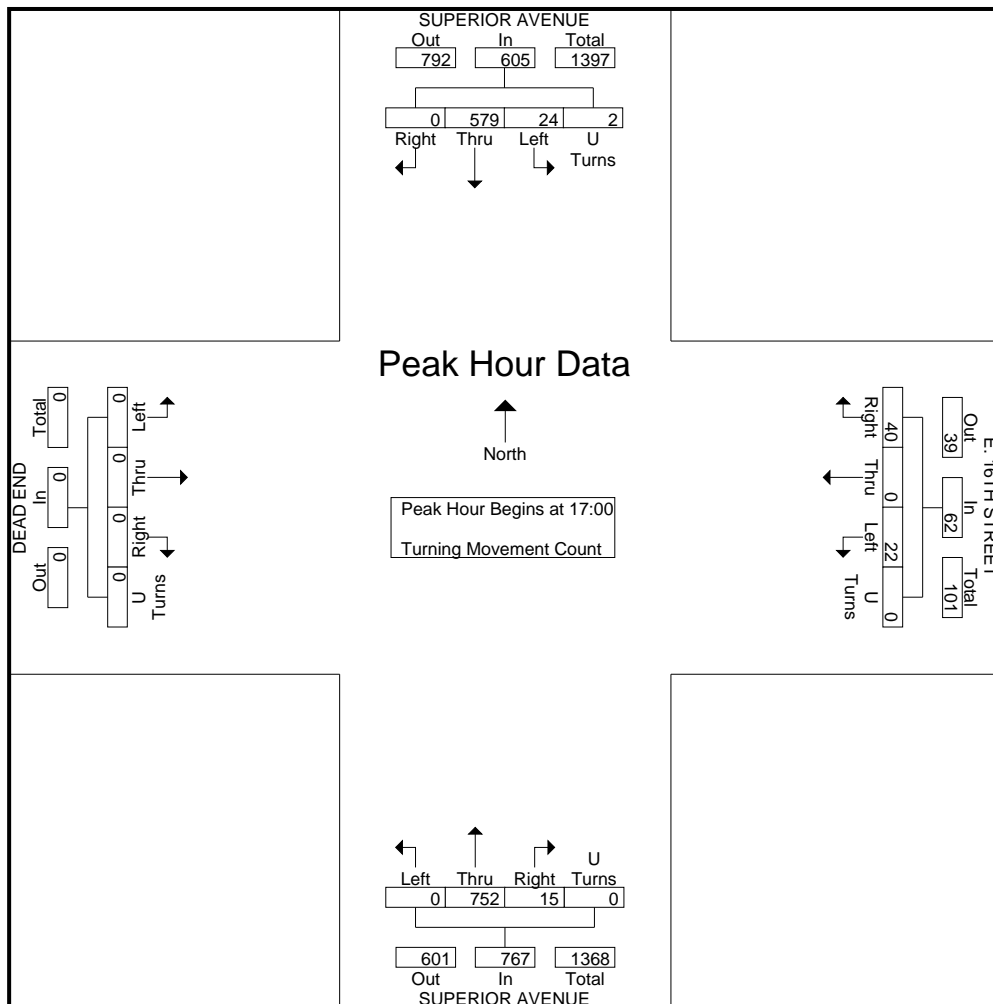

City: COSTA MESA
 N-S Direction: OLD NEWPORT BOULEVARD (W)
 E-W Direction: 16TH STREET

File Name : h2302002
 Site Code : 00000000
 Start Date : 2/2/2023
 Page No : 1

Groups Printed- Turning Movement Count

Start Time	DRIVEWAY Southbound				16TH STREET Westbound				OLD NEWPORT BOUEVARD Northbound				16TH STREET Eastbound				Int. Total
	Right	Thru	Left	U Turns	Right	Thru	Left	U Turns	Right	Thru	Left	U Turns	Right	Thru	Left	U Turns	
11:00	1	0	1	0	1	12	3	0	6	0	0	0	2	7	0	0	33
11:15	2	0	3	0	1	15	6	0	3	0	0	1	0	5	1	0	37
11:30	0	0	3	0	2	15	4	0	1	0	0	0	2	10	1	0	38
11:45	0	0	2	0	2	15	4	0	4	0	0	0	3	17	0	0	47
Total	3	0	9	0	6	57	17	0	14	0	0	1	7	39	2	0	155
12:00	0	2	2	0	2	16	6	1	2	0	1	0	3	15	2	0	52
12:15	0	0	3	0	1	24	6	0	4	0	2	0	1	12	0	0	53
12:30	0	1	2	0	2	11	4	0	5	0	1	0	2	11	1	0	40
12:45	0	1	1	0	4	17	4	0	0	1	0	0	1	12	1	0	42
Total	0	4	8	0	9	68	20	1	11	1	4	0	7	50	4	0	187
17:00	0	0	2	0	1	13	4	1	5	0	0	0	2	14	0	1	43
17:15	1	0	2	0	1	23	6	0	4	0	1	0	0	16	1	0	55
17:30	0	0	2	0	1	13	1	0	2	0	0	0	0	7	0	0	26
17:45	1	0	3	0	0	11	2	1	1	0	1	0	1	8	0	0	29
Total	2	0	9	0	3	60	13	2	12	0	2	0	3	45	1	1	153
18:00	9	1	1	0	1	17	3	0	3	0	0	0	0	13	0	0	48
18:15	1	0	0	0	0	10	1	0	6	0	0	0	1	5	0	0	24
18:30	0	0	0	0	0	13	1	0	2	0	1	0	3	7	0	0	27
18:45	0	0	0	0	0	19	1	0	3	0	1	0	1	6	0	0	31
Total	10	1	1	0	1	59	6	0	14	0	2	0	5	31	0	0	130
Grand Total	15	5	27	0	19	244	56	3	51	1	8	1	22	165	7	1	625
Apprch %	31.9	10.6	57.4	0	5.9	75.8	17.4	0.9	83.6	1.6	13.1	1.6	11.3	84.6	3.6	0.5	
Total %	2.4	0.8	4.3	0	3	39	9	0.5	8.2	0.2	1.3	0.2	3.5	26.4	1.1	0.2	

City: COSTA MESA
 N-S Direction: OLD NEWPORT BOULEVARD (W)
 E-W Direction: 16TH STREET

File Name : h2302002
 Site Code : 00000000
 Start Date : 2/2/2023
 Page No : 2

Start Time	DRIVEWAY Southbound					16TH STREET Westbound					OLD NEWPORT BOUEVARD Northbound					16TH STREET Eastbound					Int. Total
	Right	Thru	Left	U Turns	App. Total	Right	Thru	Left	U Turns	App. Total	Right	Thru	Left	U Turns	App. Total	Right	Thru	Left	U Turns	App. Total	
Peak Hour Analysis From 11:00 to 12:45 - Peak 1 of 1																					
Peak Hour for Entire Intersection Begins at 11:45																					
11:45	0	0	2	0	2	2	15	4	0	21	4	0	0	0	4	3	17	0	0	20	47
12:00	0	2	2	0	4	2	16	6	1	25	2	0	1	0	3	3	15	2	0	20	52
12:15	0	0	3	0	3	1	24	6	0	31	4	0	2	0	6	1	12	0	0	13	53
12:30	0	1	2	0	3	2	11	4	0	17	5	0	1	0	6	2	11	1	0	14	40
Total Volume	0	3	9	0	12	7	66	20	1	94	15	0	4	0	19	9	55	3	0	67	192
% App. Total	0	25	75	0		7.4	70.2	21.3	1.1		78.9	0	21.1	0		13.4	82.1	4.5	0		
PHF	.000	.375	.750	.000	.750	.875	.688	.833	.250	.758	.750	.000	.500	.000	.792	.750	.809	.375	.000	.838	.906

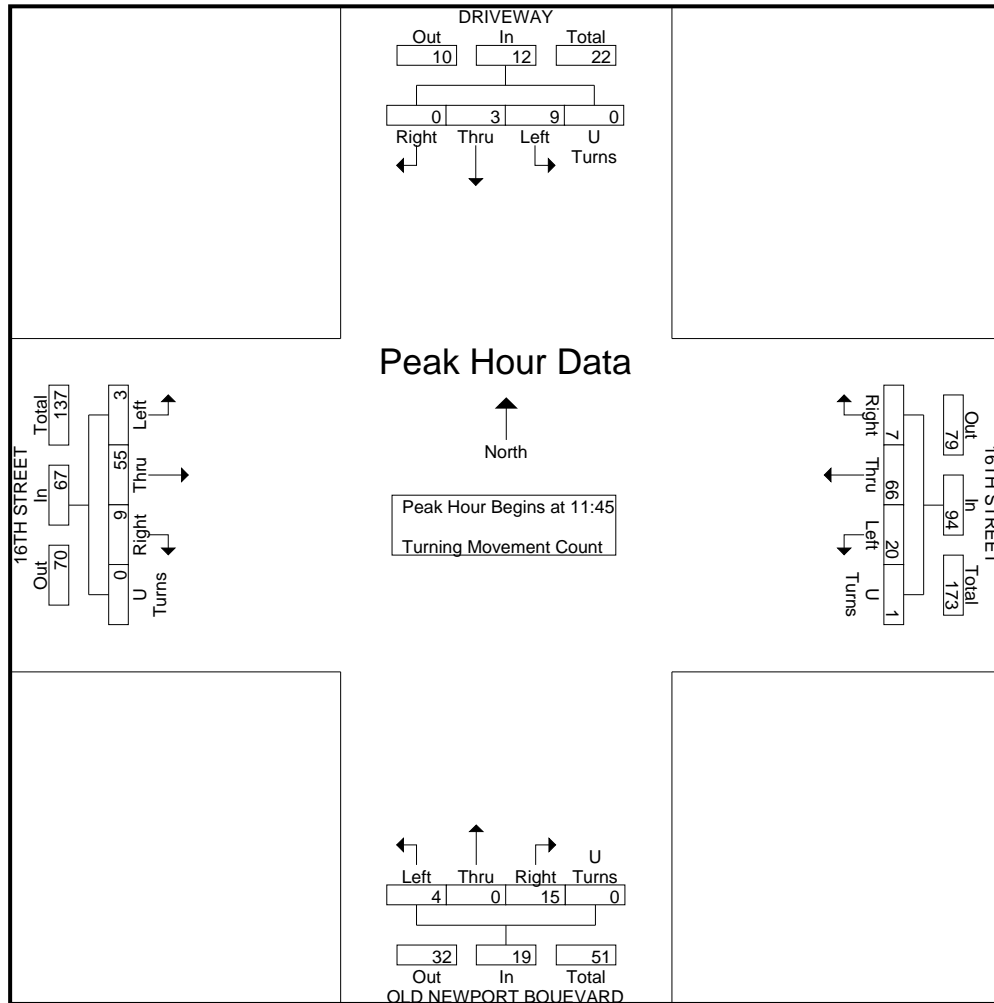

City: COSTA MESA
 N-S Direction: OLD NEWPORT BOULEVARD (W)
 E-W Direction: 16TH STREET

File Name : h2302002
 Site Code : 00000000
 Start Date : 2/2/2023
 Page No : 3

Start Time	DRIVEWAY Southbound					16TH STREET Westbound					OLD NEWPORT BOUEVARD Northbound					16TH STREET Eastbound					Int. Total
	Right	Thru	Left	U Turns	App. Total	Right	Thru	Left	U Turns	App. Total	Right	Thru	Left	U Turns	App. Total	Right	Thru	Left	U Turns	App. Total	
17:15	1	0	2	0	3	1	23	6	0	30	4	0	1	0	5	0	16	1	0	17	55
17:30	0	0	2	0	2	1	13	1	0	15	2	0	0	0	2	0	7	0	0	7	26
17:45	1	0	3	0	4	0	11	2	1	14	1	0	1	0	2	1	8	0	0	9	29
18:00	9	1	1	0	11	1	17	3	0	21	3	0	0	0	3	0	13	0	0	13	48
Total Volume	11	1	8	0	20	3	64	12	1	80	10	0	2	0	12	1	44	1	0	46	158
% App. Total	55	5	40	0		3.8	80	15	1.2		83.3	0	16.7	0		2.2	95.7	2.2	0		
PHF	.306	.250	.667	.000	.455	.750	.696	.500	.250	.667	.625	.000	.500	.000	.600	.250	.688	.250	.000	.676	.718

Peak Hour Analysis From 17:00 to 18:45 - Peak 1 of 1
 Peak Hour for Entire Intersection Begins at 17:15

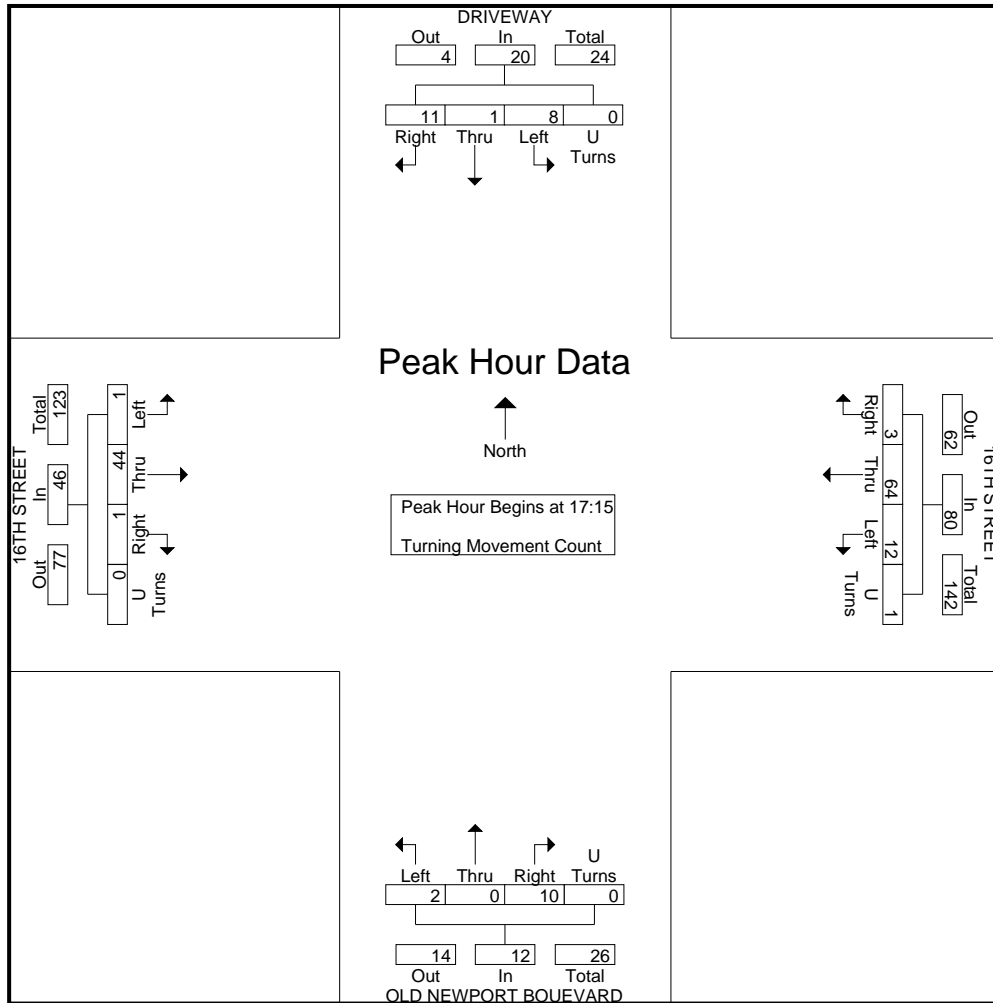

City: COSTA MESA
 N-S Direction: NEWPORT BOULEVARD
 E-W Direction: E. 16TH STREET

File Name : H2302004
 Site Code : 00000000
 Start Date : 2/2/2023
 Page No : 1

Groups Printed- Turning Movement Count

Start Time	NEWPORT BOULEVARD Southbound				E. 16TH STREET Westbound				NEWPORT BOULEVARD Northbound				E. 16TH STREET Eastbound				Int. Total
	Right	Thru	Left	U Turns	Right	Thru	Left	U Turns	Right	Thru	Left	U Turns	Right	Thru	Left	U Turns	
11:00	8	407	15	6	19	11	15	0	17	417	0	2	2	5	5	0	929
11:15	6	424	10	8	21	5	16	0	23	429	9	1	1	3	4	0	960
11:30	5	441	11	9	19	9	14	0	22	458	7	2	2	6	7	0	1012
11:45	6	430	14	7	17	9	14	0	21	411	3	2	7	8	9	0	958
Total	25	1702	50	30	76	34	59	0	83	1715	19	7	12	22	25	0	3859
12:00	11	422	10	11	19	14	23	0	20	432	0	7	2	6	11	0	988
12:15	10	378	10	13	10	10	17	0	15	414	5	3	6	5	7	0	903
12:30	7	430	7	12	16	9	19	0	18	432	2	0	1	7	10	0	970
12:45	9	431	10	12	20	13	24	0	21	438	7	2	3	9	3	0	1002
Total	37	1661	37	48	65	46	83	0	74	1716	14	12	12	27	31	0	3863
17:00	2	471	13	5	13	13	24	0	16	483	3	2	3	10	10	0	1068
17:15	2	389	5	1	16	15	28	0	26	396	5	1	7	9	4	0	904
17:30	4	471	6	4	14	11	16	0	16	401	2	0	4	5	2	0	956
17:45	4	387	12	3	10	8	17	0	16	409	3	1	5	8	0	0	883
Total	12	1718	36	13	53	47	85	0	74	1689	13	4	19	32	16	0	3811
18:00	6	442	9	1	10	9	11	0	11	370	1	0	3	10	4	0	887
18:15	5	443	15	5	15	11	12	0	9	373	0	0	2	6	2	0	898
18:30	7	393	5	0	10	5	9	0	8	352	3	0	1	6	2	0	801
18:45	8	406	13	0	8	10	7	0	8	306	1	0	0	7	2	0	776
Total	26	1684	42	6	43	35	39	0	36	1401	5	0	6	29	10	0	3362
Grand Total	100	6765	165	97	237	162	266	0	267	6521	51	23	49	110	82	0	14895
Apprch %	1.4	94.9	2.3	1.4	35.6	24.4	40	0	3.9	95	0.7	0.3	20.3	45.6	34	0	
Total %	0.7	45.4	1.1	0.7	1.6	1.1	1.8	0	1.8	43.8	0.3	0.2	0.3	0.7	0.6	0	

City: COSTA MESA
 N-S Direction: NEWPORT BOULEVARD
 E-W Direction: E. 16TH STREET

File Name : H2302004
 Site Code : 00000000
 Start Date : 2/2/2023
 Page No : 2

Start Time	NEWPORT BOULEVARD Southbound					E. 16TH STREET Westbound					NEWPORT BOULEVARD Northbound					E. 16TH STREET Eastbound					Int. Total
	Right	Thru	Left	U Turns	App. Total	Right	Thru	Left	U Turns	App. Total	Right	Thru	Left	U Turns	App. Total	Right	Thru	Left	U Turns	App. Total	
Peak Hour Analysis From 11:00 to 12:45 - Peak 1 of 1																					
Peak Hour for Entire Intersection Begins at 11:15																					
11:15	6	424	10	8	448	21	5	16	0	42	23	429	9	1	462	1	3	4	0	8	960
11:30	5	441	11	9	466	19	9	14	0	42	22	458	7	2	489	2	6	7	0	15	1012
11:45	6	430	14	7	457	17	9	14	0	40	21	411	3	2	437	7	8	9	0	24	958
12:00	11	422	10	11	454	19	14	23	0	56	20	432	0	7	459	2	6	11	0	19	988
Total Volume	28	1717	45	35	1825	76	37	67	0	180	86	1730	19	12	1847	12	23	31	0	66	3918
% App. Total	1.5	94.1	2.5	1.9		42.2	20.6	37.2	0		4.7	93.7	1	0.6		18.2	34.8	47	0		
PHF	.636	.973	.804	.795	.979	.905	.661	.728	.000	.804	.935	.944	.528	.429	.944	.429	.719	.705	.000	.688	.968

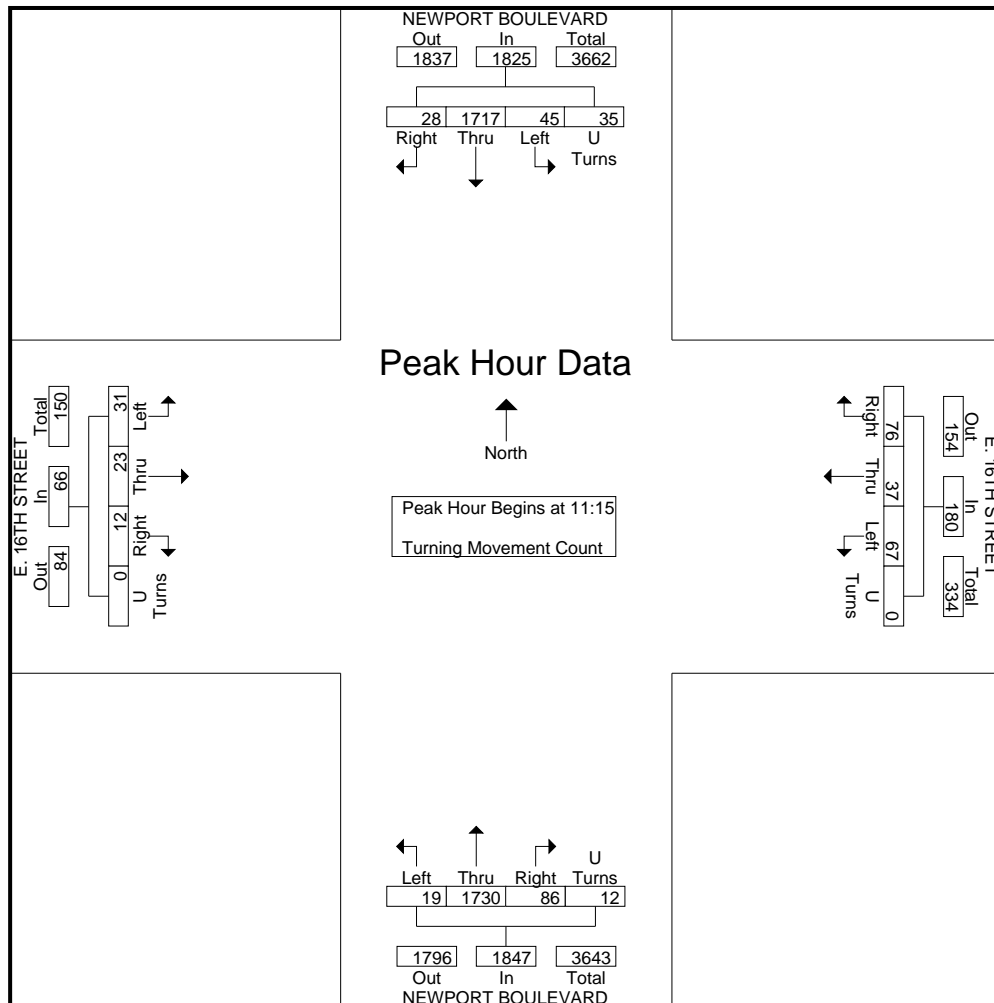

City: COSTA MESA
 N-S Direction: NEWPORT BOULEVARD
 E-W Direction: E. 16TH STREET

File Name : H2302004
 Site Code : 0000000
 Start Date : 2/2/2023
 Page No : 3

Start Time	NEWPORT BOULEVARD Southbound					E. 16TH STREET Westbound					NEWPORT BOULEVARD Northbound					E. 16TH STREET Eastbound					Int. Total
	Right	Thru	Left	U Turns	App. Total	Right	Thru	Left	U Turns	App. Total	Right	Thru	Left	U Turns	App. Total	Right	Thru	Left	U Turns	App. Total	
Peak Hour Analysis From 17:00 to 18:45 - Peak 1 of 1																					
Peak Hour for Entire Intersection Begins at 17:00																					
17:00	2	471	13	5	491	13	13	24	0	50	16	483	3	2	504	3	10	10	0	23	1068
17:15	2	389	5	1	397	16	15	28	0	59	26	396	5	1	428	7	9	4	0	20	904
17:30	4	471	6	4	485	14	11	16	0	41	16	401	2	0	419	4	5	2	0	11	956
17:45	4	387	12	3	406	10	8	17	0	35	16	409	3	1	429	5	8	0	0	13	883
Total Volume	12	1718	36	13	1779	53	47	85	0	185	74	1689	13	4	1780	19	32	16	0	67	3811
% App. Total	0.7	96.6	2	0.7		28.6	25.4	45.9	0		4.2	94.9	0.7	0.2		28.4	47.8	23.9	0		
PHF	.750	.912	.692	.650	.906	.828	.783	.759	.000	.784	.712	.874	.650	.500	.883	.679	.800	.400	.000	.728	.892

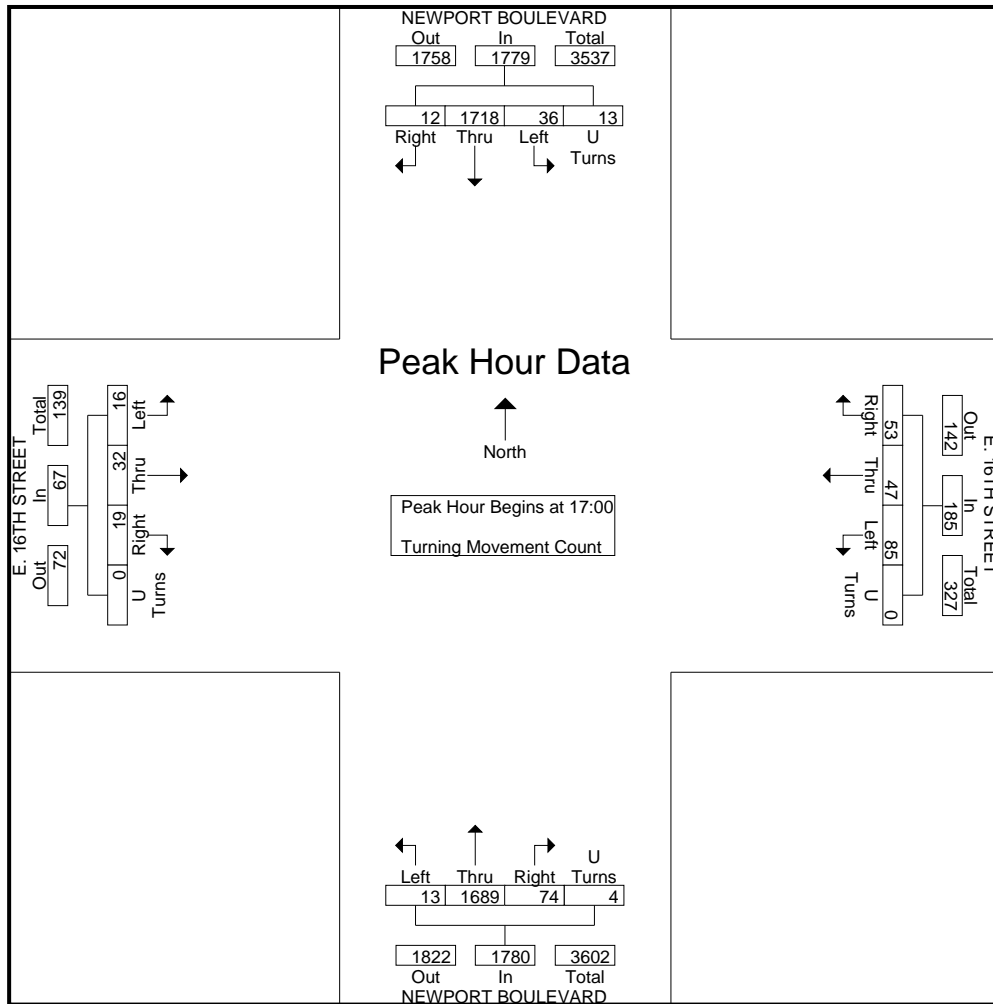

City: COSTA MESA
 N-S Direction: SUPERIOR AVENUE
 E-W Direction: INDUSTRIAL WAY

File Name : H2302014
 Site Code : 00000000
 Start Date : 2/2/2023
 Page No : 1

Groups Printed- Turning Movement Count

Start Time	SUPERIOR AVENUE Southbound				INDUSTRIAL WAY Westbound				SUPERIOR AVENUE Northbound				INDUSTRIAL WAY Eastbound				Int. Total
	Right	Thru	Left	U Turns	Right	Thru	Left	U Turns	Right	Thru	Left	U Turns	Right	Thru	Left	U Turns	
11:00	19	112	9	0	7	16	10	0	25	143	9	0	19	18	16	0	403
11:15	18	105	12	0	11	27	17	0	26	147	10	0	14	20	18	0	425
11:30	34	126	13	0	7	11	13	0	24	144	5	0	18	22	19	0	436
11:45	22	107	10	0	9	13	9	0	18	148	7	1	17	18	25	0	404
Total	93	450	44	0	34	67	49	0	93	582	31	1	68	78	78	0	1668
12:00	25	89	3	0	3	19	3	0	25	156	13	0	13	32	20	0	401
12:15	22	147	6	0	10	15	8	0	23	142	9	1	14	17	21	0	435
12:30	22	129	12	0	7	19	18	0	20	132	15	0	15	16	24	0	429
12:45	17	143	8	0	10	21	16	0	16	124	14	1	10	20	18	0	418
Total	86	508	29	0	30	74	45	0	84	554	51	2	52	85	83	0	1683
17:00	17	134	4	0	8	17	9	0	22	191	9	0	25	32	23	0	491
17:15	10	123	5	0	3	30	4	0	17	145	15	0	15	22	21	0	410
17:30	13	106	6	0	6	18	6	0	10	149	13	0	13	17	20	0	377
17:45	14	114	9	2	4	11	5	0	8	113	7	0	13	14	16	0	330
Total	54	477	24	2	21	76	24	0	57	598	44	0	66	85	80	0	1608
18:00	18	119	6	0	8	18	6	0	10	128	6	0	14	10	14	0	357
18:15	17	114	2	0	3	10	10	0	1	99	4	2	11	10	16	0	299
18:30	14	91	2	1	5	9	3	0	4	78	5	1	17	12	19	0	261
18:45	13	88	10	0	4	9	5	0	8	88	2	0	4	11	3	1	246
Total	62	412	20	1	20	46	24	0	23	393	17	3	46	43	52	1	1163
Grand Total	295	1847	117	3	105	263	142	0	257	2127	143	6	232	291	293	1	6122
Apprch %	13	81.7	5.2	0.1	20.6	51.6	27.8	0	10.1	84	5.6	0.2	28.4	35.6	35.9	0.1	
Total %	4.8	30.2	1.9	0	1.7	4.3	2.3	0	4.2	34.7	2.3	0.1	3.8	4.8	4.8	0	

City: COSTA MESA
 N-S Direction: SUPERIOR AVENUE
 E-W Direction: INDUSTRIAL WAY

File Name : H2302014
 Site Code : 00000000
 Start Date : 2/2/2023
 Page No : 2

Start Time	SUPERIOR AVENUE Southbound					INDUSTRIAL WAY Westbound					SUPERIOR AVENUE Northbound					INDUSTRIAL WAY Eastbound					Int. Total
	Right	Thru	Left	U Turns	App. Total	Right	Thru	Left	U Turns	App. Total	Right	Thru	Left	U Turns	App. Total	Right	Thru	Left	U Turns	App. Total	
Peak Hour Analysis From 11:00 to 12:45 - Peak 1 of 1																					
Peak Hour for Entire Intersection Begins at 12:00																					
12:00	25	89	3	0	117	3	19	3	0	25	25	156	13	0	194	13	32	20	0	65	401
12:15	22	147	6	0	175	10	15	8	0	33	23	142	9	1	175	14	17	21	0	52	435
12:30	22	129	12	0	163	7	19	18	0	44	20	132	15	0	167	15	16	24	0	55	429
12:45	17	143	8	0	168	10	21	16	0	47	16	124	14	1	155	10	20	18	0	48	418
Total Volume	86	508	29	0	623	30	74	45	0	149	84	554	51	2	691	52	85	83	0	220	1683
% App. Total	13.8	81.5	4.7	0		20.1	49.7	30.2	0		12.2	80.2	7.4	0.3		23.6	38.6	37.7	0		
PHF	.860	.864	.604	.000	.890	.750	.881	.625	.000	.793	.840	.888	.850	.500	.890	.867	.664	.865	.000	.846	.967

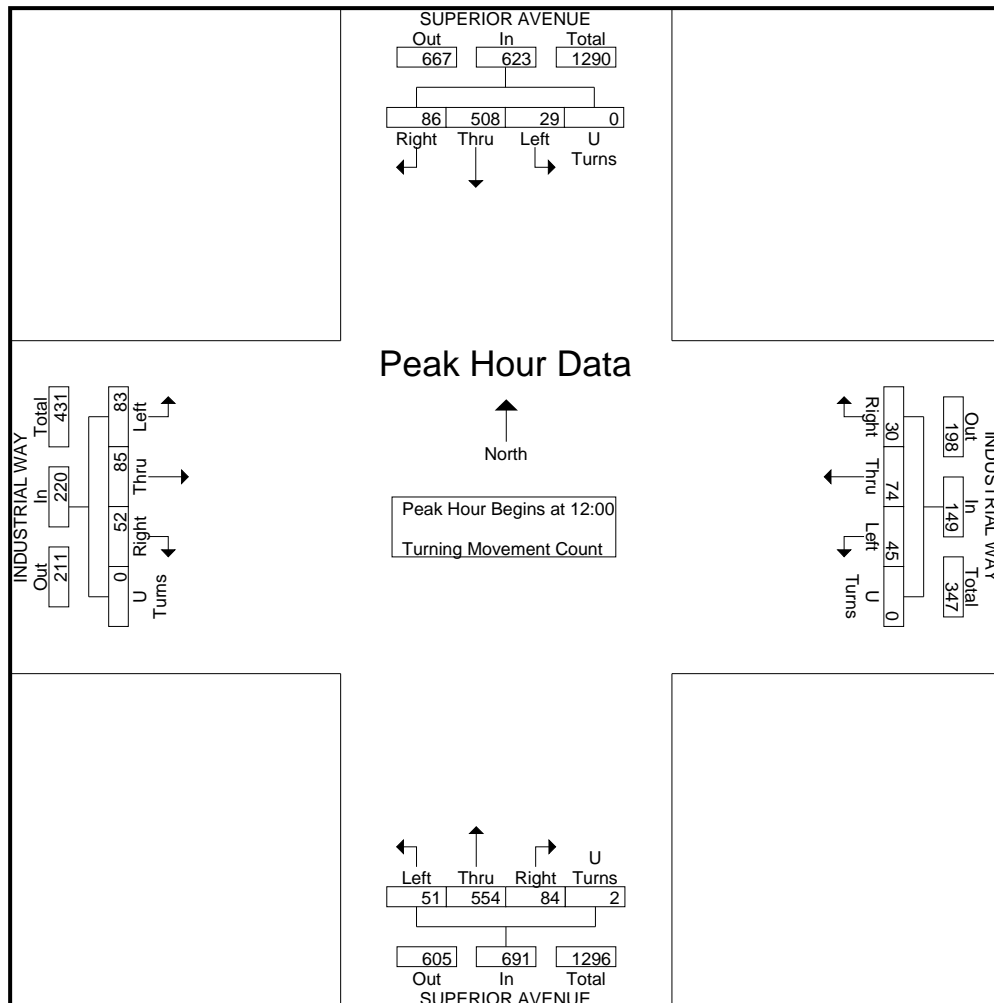

City: COSTA MESA
 N-S Direction: SUPERIOR AVENUE
 E-W Direction: INDUSTRIAL WAY

File Name : H2302014
 Site Code : 0000000
 Start Date : 2/2/2023
 Page No : 3

Start Time	SUPERIOR AVENUE Southbound					INDUSTRIAL WAY Westbound					SUPERIOR AVENUE Northbound					INDUSTRIAL WAY Eastbound					Int. Total
	Right	Thru	Left	U Turns	App. Total	Right	Thru	Left	U Turns	App. Total	Right	Thru	Left	U Turns	App. Total	Right	Thru	Left	U Turns	App. Total	
Peak Hour Analysis From 17:00 to 18:45 - Peak 1 of 1																					
Peak Hour for Entire Intersection Begins at 17:00																					
17:00	17	134	4	0	155	8	17	9	0	34	22	191	9	0	222	25	32	23	0	80	491
17:15	10	123	5	0	138	3	30	4	0	37	17	145	15	0	177	15	22	21	0	58	410
17:30	13	106	6	0	125	6	18	6	0	30	10	149	13	0	172	13	17	20	0	50	377
17:45	14	114	9	2	139	4	11	5	0	20	8	113	7	0	128	13	14	16	0	43	330
Total Volume	54	477	24	2	557	21	76	24	0	121	57	598	44	0	699	66	85	80	0	231	1608
% App. Total	9.7	85.6	4.3	0.4		17.4	62.8	19.8	0		8.2	85.6	6.3	0		28.6	36.8	34.6	0		
PHF	.794	.890	.667	.250	.898	.656	.633	.667	.000	.818	.648	.783	.733	.000	.787	.660	.664	.870	.000	.722	.819

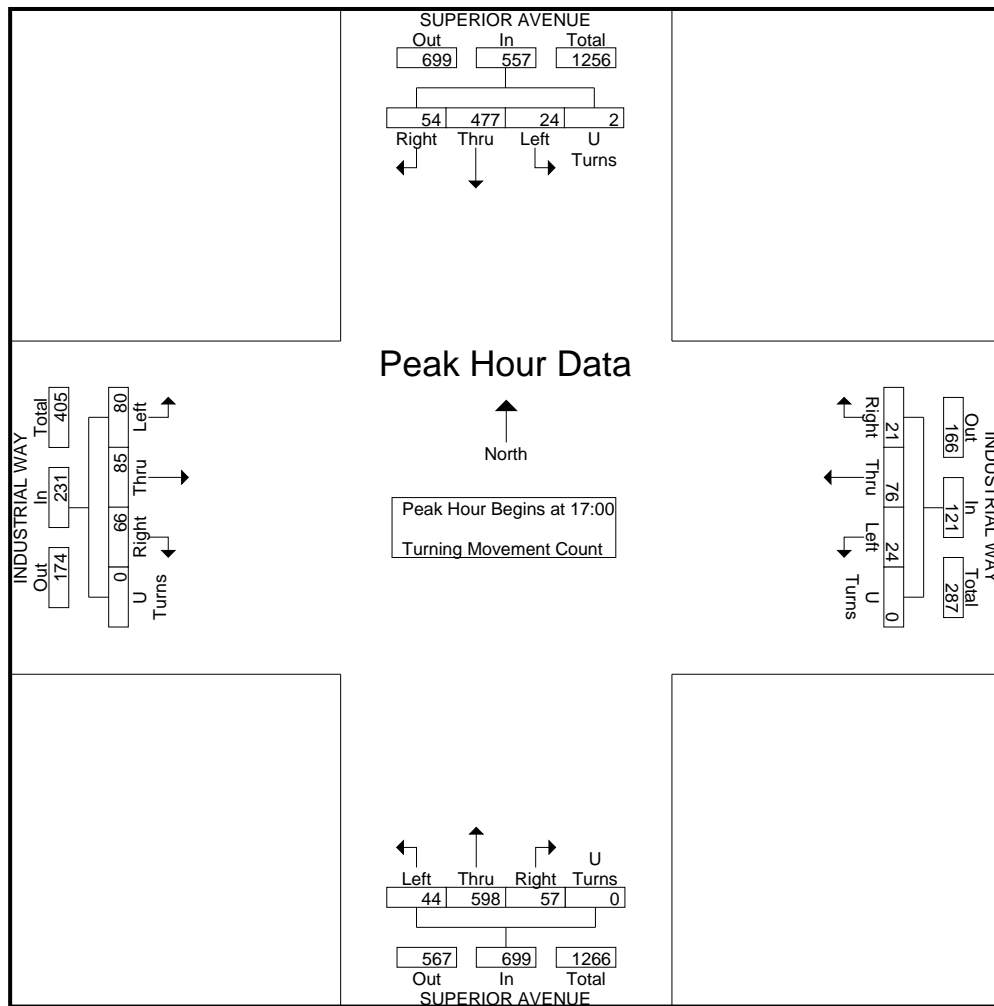

City: COSTA MESA
 N-S Direction: OLD NEWPORT BOULEVARD (W)
 E-W Direction: INDUSTRIAL WAY

File Name : H2302006
 Site Code : 00000000
 Start Date : 2/2/2023
 Page No : 1

Groups Printed- Turning Movement Count

Start Time	OLD NEWPORT BOULEVARD Southbound				INDUSTRIAL WAY Westbound				DRIVEWAY Northbound				INDUSTRIAL WAY Eastbound				Int. Total
	Right	Thru	Left	U Turns	Right	Thru	Left	U Turns	Right	Thru	Left	U Turns	Right	Thru	Left	U Turns	
11:00	2	0	2	0	5	31	5	0	5	0	6	0	9	43	0	0	108
11:15	2	0	3	0	1	36	2	0	6	0	2	0	3	50	0	0	105
11:30	1	0	2	0	2	37	8	0	5	0	2	0	3	48	0	0	108
11:45	3	0	2	0	1	20	10	0	15	0	2	0	4	43	0	0	100
Total	8	0	9	0	9	124	25	0	31	0	12	0	19	184	0	0	421
12:00	3	2	3	0	1	25	12	0	10	1	5	0	6	48	2	0	118
12:15	0	1	3	0	2	32	8	0	9	1	7	0	7	37	2	1	110
12:30	7	0	2	0	2	36	10	0	16	0	6	0	5	40	0	0	124
12:45	1	1	2	0	1	31	11	0	13	0	4	0	5	46	3	0	118
Total	11	4	10	0	6	124	41	0	48	2	22	0	23	171	7	1	470
17:00	6	0	2	0	5	33	4	0	0	0	1	0	2	58	0	0	111
17:15	4	0	3	0	1	30	7	0	6	0	1	0	2	40	0	0	94
17:30	2	0	1	0	1	27	3	0	6	0	3	0	1	32	1	0	77
17:45	0	0	0	0	0	17	2	0	2	0	2	0	4	29	0	0	56
Total	12	0	6	0	7	107	16	0	14	0	7	0	9	159	1	0	338
18:00	3	0	0	0	1	27	4	0	2	1	5	0	3	20	0	0	66
18:15	2	0	0	0	1	16	1	0	2	0	2	0	2	15	0	0	41
18:30	0	0	2	0	1	21	4	0	2	0	2	0	0	16	0	1	49
18:45	1	0	1	0	2	11	4	0	4	0	3	0	3	26	0	0	55
Total	6	0	3	0	5	75	13	0	10	1	12	0	8	77	0	1	211
Grand Total	37	4	28	0	27	430	95	0	103	3	53	0	59	591	8	2	1440
Apprch %	53.6	5.8	40.6	0	4.9	77.9	17.2	0	64.8	1.9	33.3	0	8.9	89.5	1.2	0.3	
Total %	2.6	0.3	1.9	0	1.9	29.9	6.6	0	7.2	0.2	3.7	0	4.1	41	0.6	0.1	

City: COSTA MESA
 N-S Direction: OLD NEWPORT BOULEVARD (W)
 E-W Direction: INDUSTRIAL WAY

File Name : H2302006
 Site Code : 0000000
 Start Date : 2/2/2023
 Page No : 2

Start Time	OLD NEWPORT BOULEVARD Southbound					INDUSTRIAL WAY Westbound					DRIVEWAY Northbound					INDUSTRIAL WAY Eastbound					Int. Total
	Right	Thru	Left	U Turns	App. Total	Right	Thru	Left	U Turns	App. Total	Right	Thru	Left	U Turns	App. Total	Right	Thru	Left	U Turns	App. Total	
Peak Hour Analysis From 11:00 to 12:45 - Peak 1 of 1																					
Peak Hour for Entire Intersection Begins at 12:00																					
12:00	3	2	3	0	8	1	25	12	0	38	10	1	5	0	16	6	48	2	0	56	118
12:15	0	1	3	0	4	2	32	8	0	42	9	1	7	0	17	7	37	2	1	47	110
12:30	7	0	2	0	9	2	36	10	0	48	16	0	6	0	22	5	40	0	0	45	124
12:45	1	1	2	0	4	1	31	11	0	43	13	0	4	0	17	5	46	3	0	54	118
Total Volume	11	4	10	0	25	6	124	41	0	171	48	2	22	0	72	23	171	7	1	202	470
% App. Total	44	16	40	0		3.5	72.5	24	0		66.7	2.8	30.6	0		11.4	84.7	3.5	0.5		
PHF	.393	.500	.833	.000	.694	.750	.861	.854	.000	.891	.750	.500	.786	.000	.818	.821	.891	.583	.250	.902	.948

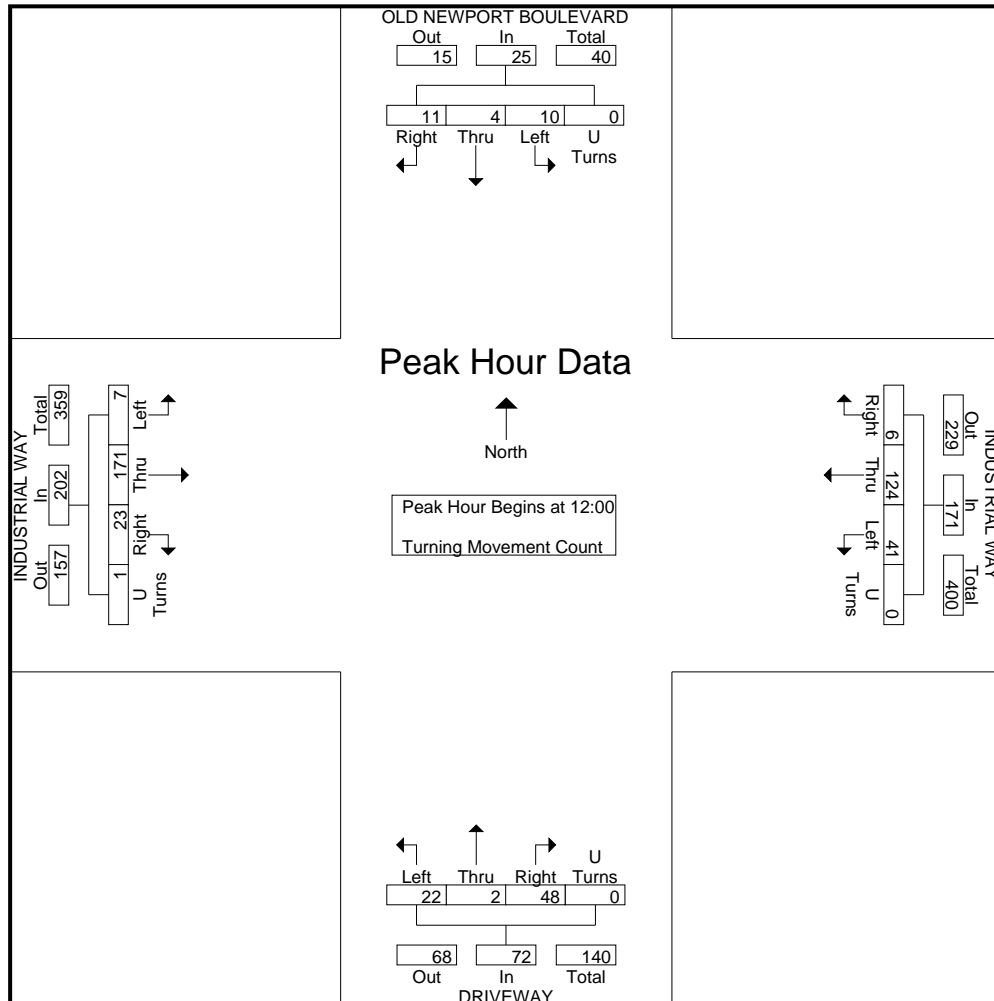

City: COSTA MESA
 N-S Direction: OLD NEWPORT BOULEVARD (W)
 E-W Direction: INDUSTRIAL WAY

File Name : H2302006
 Site Code : 0000000
 Start Date : 2/2/2023
 Page No : 3

Start Time	OLD NEWPORT BOULEVARD Southbound					INDUSTRIAL WAY Westbound					DRIVEWAY Northbound					INDUSTRIAL WAY Eastbound					Int. Total
	Right	Thru	Left	U Turns	App. Total	Right	Thru	Left	U Turns	App. Total	Right	Thru	Left	U Turns	App. Total	Right	Thru	Left	U Turns	App. Total	
17:00	6	0	2	0	8	5	33	4	0	42	0	0	1	0	1	2	58	0	0	60	111
17:15	4	0	3	0	7	1	30	7	0	38	6	0	1	0	7	2	40	0	0	42	94
17:30	2	0	1	0	3	1	27	3	0	31	6	0	3	0	9	1	32	1	0	34	77
17:45	0	0	0	0	0	0	17	2	0	19	2	0	2	0	4	4	29	0	0	33	56
Total Volume	12	0	6	0	18	7	107	16	0	130	14	0	7	0	21	9	159	1	0	169	338
% App. Total	66.7	0	33.3	0		5.4	82.3	12.3	0		66.7	0	33.3	0		5.3	94.1	0.6	0		
PHF	.500	.000	.500	.000	.563	.350	.811	.571	.000	.774	.583	.000	.583	.000	.583	.563	.685	.250	.000	.704	.761

Peak Hour Analysis From 17:00 to 18:45 - Peak 1 of 1
 Peak Hour for Entire Intersection Begins at 17:00

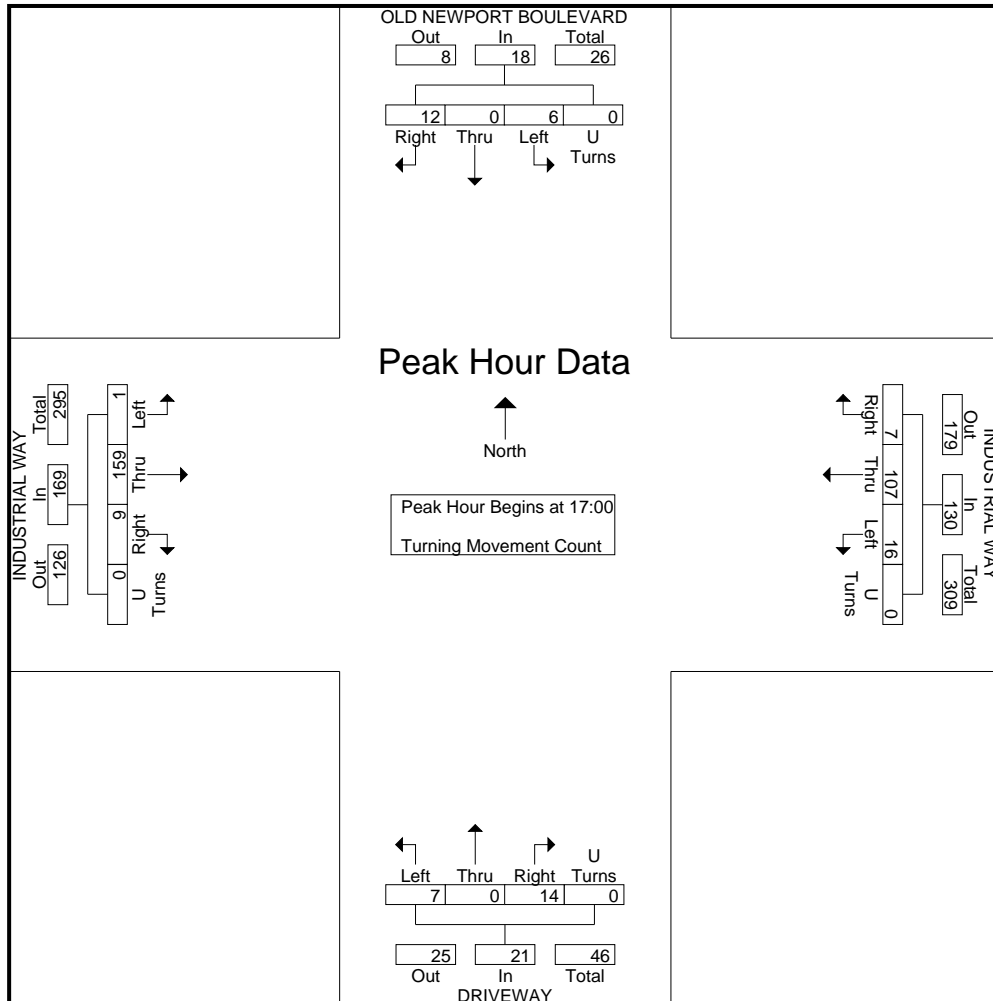

City: COSTA MESA
 N-S Direction: NEWPORT BOULEVARD
 E-W Direction: INDUSTRIAL WAY

File Name : H2302008
 Site Code : 00000000
 Start Date : 2/2/2023
 Page No : 1

Groups Printed- Turning Movement Count

Start Time	NEWPORT BOULEVARD Southbound				INDUSTRIAL WAY Westbound				NEWPORT BOULEVARD Northbound				INDUSTRIAL WAY Eastbound				Int. Total
	Right	Thru	Left	U Turns	Right	Thru	Left	U Turns	Right	Thru	Left	U Turns	Right	Thru	Left	U Turns	
11:00	15	403	18	0	20	14	2	0	3	397	13	1	20	14	16	0	936
11:15	12	377	23	0	21	15	6	0	3	421	13	1	32	16	12	0	952
11:30	19	421	31	0	29	17	3	0	2	435	12	1	29	14	9	0	1022
11:45	13	422	22	1	24	12	2	0	8	412	5	0	30	12	14	0	977
Total	59	1623	94	1	94	58	13	0	16	1665	43	3	111	56	51	0	3887
12:00	12	405	25	3	24	18	1	0	2	406	9	0	33	11	19	0	968
12:15	9	415	28	1	20	22	4	0	2	397	2	0	22	12	20	0	954
12:30	17	405	12	1	21	21	6	0	4	411	13	2	29	10	17	0	969
12:45	16	403	31	0	18	22	6	0	5	425	12	3	32	7	20	0	1000
Total	54	1628	96	5	83	83	17	0	13	1639	36	5	116	40	76	0	3891
17:00	18	481	17	0	45	20	5	0	0	456	3	1	13	21	22	0	1102
17:15	7	387	16	1	18	12	1	0	3	430	13	0	19	17	17	0	941
17:30	12	436	18	0	27	19	4	0	1	340	7	0	17	11	10	0	902
17:45	6	413	10	0	19	17	2	0	4	384	3	1	13	7	7	0	886
Total	43	1717	61	1	109	68	12	0	8	1610	26	2	62	56	56	0	3831
18:00	7	398	20	0	27	20	2	0	1	363	0	0	10	7	7	0	862
18:15	9	426	18	0	17	11	2	0	1	376	0	0	3	9	7	0	879
18:30	9	419	14	0	11	10	0	0	2	336	4	2	6	5	4	0	822
18:45	10	384	12	0	5	8	2	0	1	274	2	0	15	9	11	0	733
Total	35	1627	64	0	60	49	6	0	5	1349	6	2	34	30	29	0	3296
Grand Total	191	6595	315	7	346	258	48	0	42	6263	111	12	323	182	212	0	14905
Apprch %	2.7	92.8	4.4	0.1	53.1	39.6	7.4	0	0.7	97.4	1.7	0.2	45	25.4	29.6	0	
Total %	1.3	44.2	2.1	0	2.3	1.7	0.3	0	0.3	42	0.7	0.1	2.2	1.2	1.4	0	

City: COSTA MESA
 N-S Direction: NEWPORT BOULEVARD
 E-W Direction: INDUSTRIAL WAY

File Name : H2302008
 Site Code : 00000000
 Start Date : 2/2/2023
 Page No : 2

Start Time	NEWPORT BOULEVARD Southbound					INDUSTRIAL WAY Westbound					NEWPORT BOULEVARD Northbound					INDUSTRIAL WAY Eastbound					Int. Total
	Right	Thru	Left	U Turns	App. Total	Right	Thru	Left	U Turns	App. Total	Right	Thru	Left	U Turns	App. Total	Right	Thru	Left	U Turns	App. Total	
Peak Hour Analysis From 11:00 to 12:45 - Peak 1 of 1																					
Peak Hour for Entire Intersection Begins at 11:30																					
11:30	19	421	31	0	471	29	17	3	0	49	2	435	12	1	450	29	14	9	0	52	1022
11:45	13	422	22	1	458	24	12	2	0	38	8	412	5	0	425	30	12	14	0	56	977
12:00	12	405	25	3	445	24	18	1	0	43	2	406	9	0	417	33	11	19	0	63	968
12:15	9	415	28	1	453	20	22	4	0	46	2	397	2	0	401	22	12	20	0	54	954
Total Volume	53	1663	106	5	1827	97	69	10	0	176	14	1650	28	1	1693	114	49	62	0	225	3921
% App. Total	2.9	91	5.8	0.3		55.1	39.2	5.7	0		0.8	97.5	1.7	0.1		50.7	21.8	27.6	0		
PHF	.697	.985	.855	.417	.970	.836	.784	.625	.000	.898	.438	.948	.583	.250	.941	.864	.875	.775	.000	.893	.959

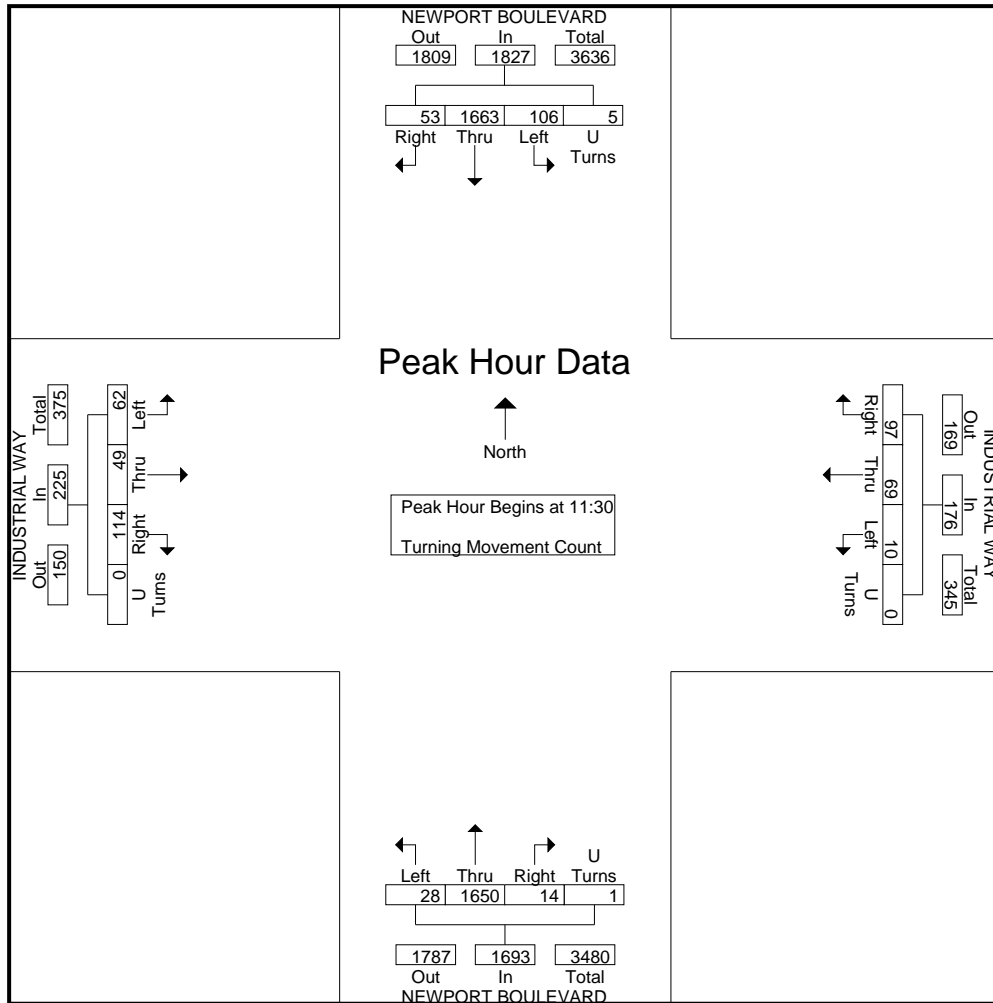

City: COSTA MESA
 N-S Direction: NEWPORT BOULEVARD
 E-W Direction: INDUSTRIAL WAY

File Name : H2302008
 Site Code : 0000000
 Start Date : 2/2/2023
 Page No : 3

Start Time	NEWPORT BOULEVARD Southbound					INDUSTRIAL WAY Westbound					NEWPORT BOULEVARD Northbound					INDUSTRIAL WAY Eastbound					Int. Total
	Right	Thru	Left	U Turns	App. Total	Right	Thru	Left	U Turns	App. Total	Right	Thru	Left	U Turns	App. Total	Right	Thru	Left	U Turns	App. Total	
Peak Hour Analysis From 17:00 to 18:45 - Peak 1 of 1																					
Peak Hour for Entire Intersection Begins at 17:00																					
17:00	18	481	17	0	516	45	20	5	0	70	0	456	3	1	460	13	21	22	0	56	1102
17:15	7	387	16	1	411	18	12	1	0	31	3	430	13	0	446	19	17	17	0	53	941
17:30	12	436	18	0	466	27	19	4	0	50	1	340	7	0	348	17	11	10	0	38	902
17:45	6	413	10	0	429	19	17	2	0	38	4	384	3	1	392	13	7	7	0	27	886
Total Volume	43	1717	61	1	1822	109	68	12	0	189	8	1610	26	2	1646	62	56	56	0	174	3831
% App. Total	2.4	94.2	3.3	0.1		57.7	36	6.3	0		0.5	97.8	1.6	0.1		35.6	32.2	32.2	0		
PHF	.597	.892	.847	.250	.883	.606	.850	.600	.000	.675	.500	.883	.500	.500	.895	.816	.667	.636	.000	.777	.869

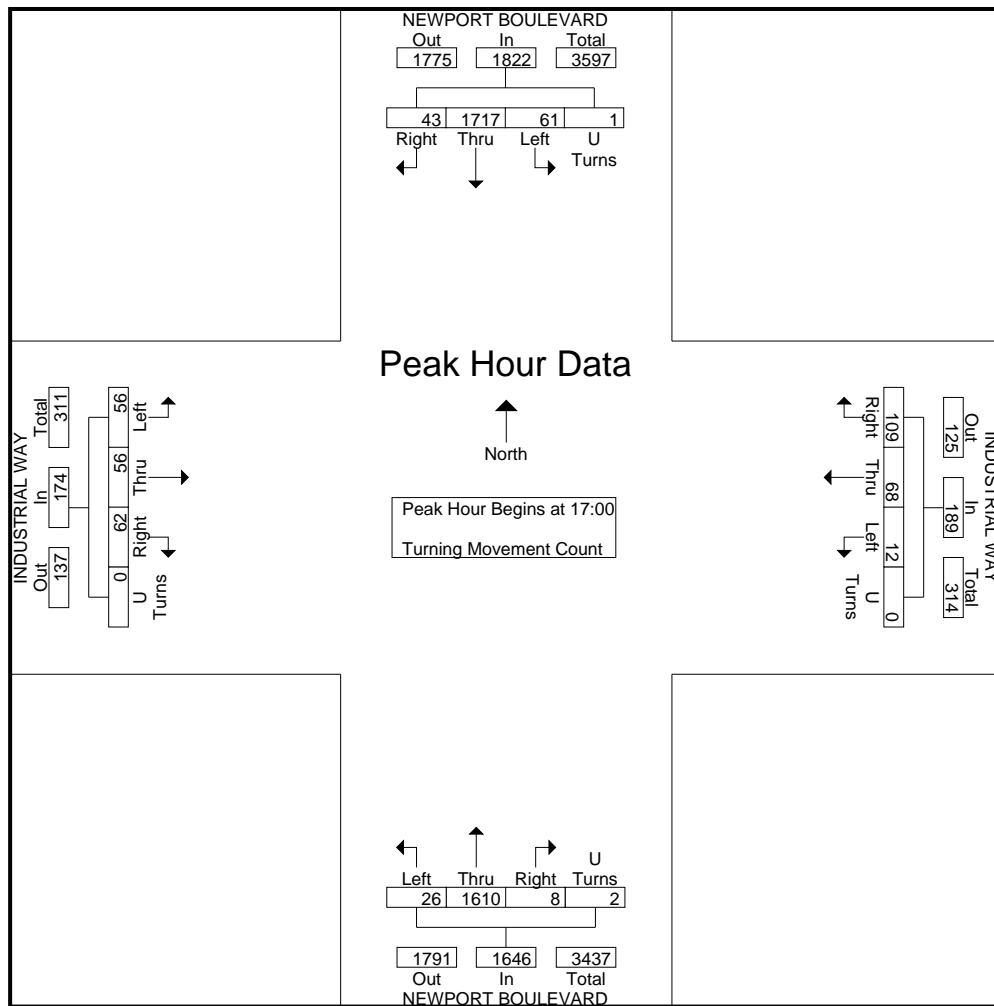

City: COSTA MESA
 N-S Direction: SUPERIOR AVENUE
 E-W Direction: W 17TH STREET

File Name : H2302013
 Site Code : 00000000
 Start Date : 2/4/2023
 Page No : 1

Groups Printed- Turning Movement Count

Start Time	SUPERIOR AVENUE Southbound				W 17TH STREET Westbound				SUPERIOR AVENUE Northbound				W 17TH STREET Eastbound				Int. Total
	Right	Thru	Left	U Turns	Right	Thru	Left	U Turns	Right	Thru	Left	U Turns	Right	Thru	Left	U Turns	
11:00	20	66	25	0	20	97	53	1	111	31	20	0	13	122	5	0	584
11:15	24	46	30	0	16	123	59	1	99	30	13	0	17	111	4	0	573
11:30	38	51	32	0	27	90	67	3	123	36	27	0	17	125	7	0	643
11:45	32	49	28	0	16	109	40	2	109	19	17	0	14	120	9	0	564
Total	114	212	115	0	79	419	219	7	442	116	77	0	61	478	25	0	2364
12:00	26	47	29	0	25	104	46	2	109	33	20	0	13	158	7	0	619
12:15	26	53	35	0	19	117	38	1	103	42	14	0	15	103	5	0	571
12:30	24	62	31	0	19	90	51	1	109	36	22	0	14	125	8	0	592
12:45	24	54	36	0	22	94	40	1	94	24	18	0	11	105	8	0	531
Total	100	216	131	0	85	405	175	5	415	135	74	0	53	491	28	0	2313
Grand Total	214	428	246	0	164	824	394	12	857	251	151	0	114	969	53	0	4677
Apprch %	24.1	48.2	27.7	0	11.8	59.1	28.3	0.9	68.1	19.9	12	0	10	85.3	4.7	0	
Total %	4.6	9.2	5.3	0	3.5	17.6	8.4	0.3	18.3	5.4	3.2	0	2.4	20.7	1.1	0	

City: COSTA MESA
 N-S Direction: SUPERIOR AVENUE
 E-W Direction: W 17TH STREET

File Name : H2302013
 Site Code : 00000000
 Start Date : 2/4/2023
 Page No : 2

Start Time	SUPERIOR AVENUE Southbound					W 17TH STREET Westbound					SUPERIOR AVENUE Northbound					W 17TH STREET Eastbound					Int. Total
	Right	Thru	Left	U Turns	App. Total	Right	Thru	Left	U Turns	App. Total	Right	Thru	Left	U Turns	App. Total	Right	Thru	Left	U Turns	App. Total	
Peak Hour Analysis From 11:00 to 12:45 - Peak 1 of 1																					
Peak Hour for Entire Intersection Begins at 11:15																					
11:15	24	46	30	0	100	16	123	59	1	199	99	30	13	0	142	17	111	4	0	132	573
11:30	38	51	32	0	121	27	90	67	3	187	123	36	27	0	186	17	125	7	0	149	643
11:45	32	49	28	0	109	16	109	40	2	167	109	19	17	0	145	14	120	9	0	143	564
12:00	26	47	29	0	102	25	104	46	2	177	109	33	20	0	162	13	158	7	0	178	619
Total Volume	120	193	119	0	432	84	426	212	8	730	440	118	77	0	635	61	514	27	0	602	2399
% App. Total	27.8	44.7	27.5	0		11.5	58.4	29	1.1		69.3	18.6	12.1	0		10.1	85.4	4.5	0		
PHF	.789	.946	.930	.000	.893	.778	.866	.791	.667	.917	.894	.819	.713	.000	.853	.897	.813	.750	.000	.846	.933

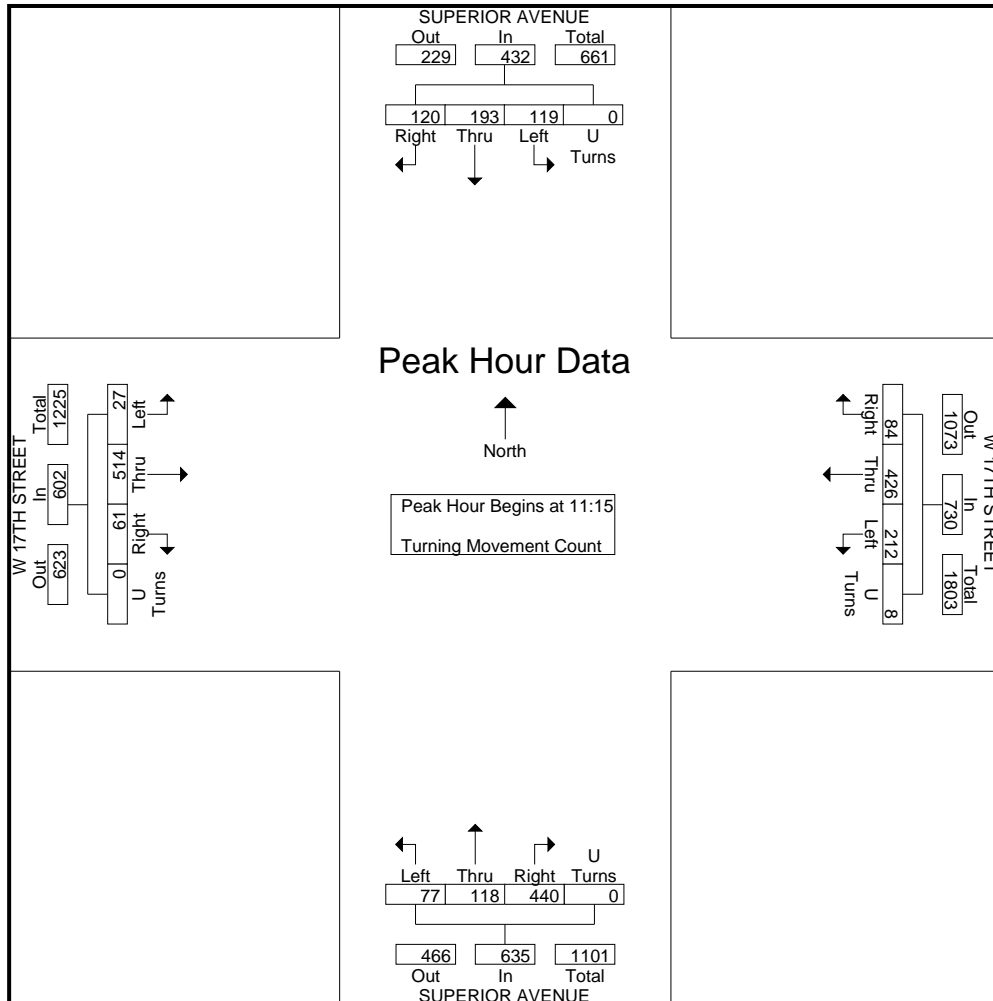

City: COSTA MESA
 N-S Direction: SUPERIOR AVENUE
 E-W Direction: E. 16TH STREET

File Name : h2302011
 Site Code : 00000000
 Start Date : 2/4/2023
 Page No : 1

Groups Printed- Turning Movement Count

Start Time	SUPERIOR AVENUE Southbound				E. 16TH STREET Westbound				SUPERIOR AVENUE Northbound				DEAD END Eastbound				Int. Total	
	Right	Thru	Left	U Turns	Right	Thru	Left	U Turns	Right	Thru	Left	U Turns	Right	Thru	Left	U Turns		
11:00	0	128	8	0	12	0	5	0	7	149	0	0	0	0	0	0	0	309
11:15	0	119	7	0	5	0	3	0	8	139	0	0	0	0	0	0	0	281
11:30	0	123	6	1	12	0	8	0	4	166	0	0	0	0	0	0	0	320
11:45	0	107	7	1	10	0	6	0	3	118	0	0	0	0	0	0	0	252
Total	0	477	28	2	39	0	22	0	22	572	0	0	0	0	0	0	0	1162
12:00	0	109	10	0	10	0	8	0	4	166	0	0	0	0	0	0	0	307
12:15	0	121	6	0	11	0	9	0	7	144	0	0	0	0	0	0	0	298
12:30	0	122	7	0	16	0	8	0	6	146	0	0	0	0	0	0	0	305
12:45	0	113	10	1	10	0	7	0	4	113	0	0	0	0	0	0	0	258
Total	0	465	33	1	47	0	32	0	21	569	0	0	0	0	0	0	0	1168
Grand Total	0	942	61	3	86	0	54	0	43	1141	0	0	0	0	0	0	0	2330
Apprch %	0	93.6	6.1	0.3	61.4	0	38.6	0	3.6	96.4	0	0	0	0	0	0	0	
Total %	0	40.4	2.6	0.1	3.7	0	2.3	0	1.8	49	0	0	0	0	0	0	0	

City: COSTA MESA
 N-S Direction: SUPERIOR AVENUE
 E-W Direction: E. 16TH STREET

File Name : h2302011
 Site Code : 00000000
 Start Date : 2/4/2023
 Page No : 2

Start Time	SUPERIOR AVENUE Southbound					E. 16TH STREET Westbound					SUPERIOR AVENUE Northbound					DEAD END Eastbound					Int. Total
	Right	Thru	Left	U Turns	App. Total	Right	Thru	Left	U Turns	App. Total	Right	Thru	Left	U Turns	App. Total	Right	Thru	Left	U Turns	App. Total	
Peak Hour Analysis From 11:00 to 12:45 - Peak 1 of 1																					
Peak Hour for Entire Intersection Begins at 11:30																					
11:30	0	123	6	1	130	12	0	8	0	20	4	166	0	0	170	0	0	0	0	0	320
11:45	0	107	7	1	115	10	0	6	0	16	3	118	0	0	121	0	0	0	0	0	252
12:00	0	109	10	0	119	10	0	8	0	18	4	166	0	0	170	0	0	0	0	0	307
12:15	0	121	6	0	127	11	0	9	0	20	7	144	0	0	151	0	0	0	0	0	298
Total Volume	0	460	29	2	491	43	0	31	0	74	18	594	0	0	612	0	0	0	0	0	1177
% App. Total	0	93.7	5.9	0.4		58.1	0	41.9	0		2.9	97.1	0	0		0	0	0	0		
PHF	.000	.935	.725	.500	.944	.896	.000	.861	.000	.925	.643	.895	.000	.000	.900	.000	.000	.000	.000	.000	.920

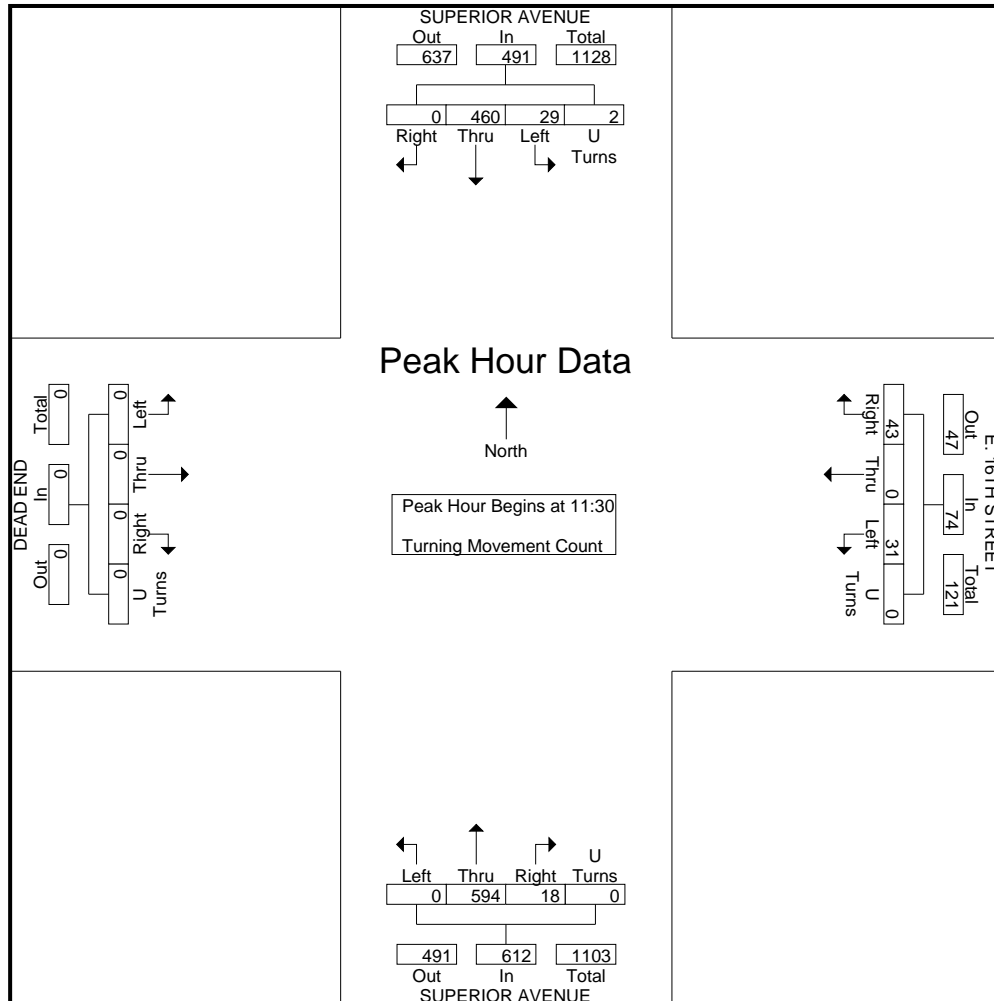

City: COSTA MESA
 N-S Direction: OLD NEWPORT BOULEVARD (W)
 E-W Direction: 16TH STREET

File Name : H2302003
 Site Code : 00000000
 Start Date : 2/4/2023
 Page No : 1

Groups Printed- Turning Movement Count

Start Time	DRIVEWAY Southbound				16TH STREET Westbound				OLD NEWPORT BOULEVARD Northbound				16TH STREET Eastbound				Int. Total
	Right	Thru	Left	U Turns	Right	Thru	Left	U Turns	Right	Thru	Left	U Turns	Right	Thru	Left	U Turns	
11:00	1	0	3	0	2	19	3	0	1	0	1	0	0	15	1	0	46
11:15	0	0	1	0	1	7	1	0	3	0	0	0	3	12	1	0	29
11:30	1	0	0	0	3	19	2	0	0	0	1	0	1	9	0	0	36
11:45	1	0	2	0	0	17	1	0	2	0	0	0	0	8	1	0	32
Total	3	0	6	0	6	62	7	0	6	0	2	0	4	44	3	0	143
12:00	0	0	5	0	0	18	5	0	5	0	1	0	1	13	0	0	48
12:15	0	0	1	0	3	19	7	0	5	0	0	0	1	8	1	0	45
12:30	2	0	2	0	2	20	3	0	3	0	1	0	2	11	0	0	46
12:45	1	0	1	0	3	16	1	0	6	0	0	0	2	10	2	0	42
Total	3	0	9	0	8	73	16	0	19	0	2	0	6	42	3	0	181
Grand Total	6	0	15	0	14	135	23	0	25	0	4	0	10	86	6	0	324
Apprch %	28.6	0	71.4	0	8.1	78.5	13.4	0	86.2	0	13.8	0	9.8	84.3	5.9	0	
Total %	1.9	0	4.6	0	4.3	41.7	7.1	0	7.7	0	1.2	0	3.1	26.5	1.9	0	

Start Time	DRIVEWAY Southbound					16TH STREET Westbound					OLD NEWPORT BOULEVARD Northbound					16TH STREET Eastbound					Int. Total
	Right	Thru	Left	U Turns	App. Total	Right	Thru	Left	U Turns	App. Total	Right	Thru	Left	U Turns	App. Total	Right	Thru	Left	U Turns	App. Total	
Peak Hour Analysis From 11:00 to 12:45 - Peak 1 of 1																					
Peak Hour for Entire Intersection Begins at 12:00																					
12:00	0	0	5	0	5	0	18	5	0	23	5	0	1	0	6	1	13	0	0	14	48
12:15	0	0	1	0	1	3	19	7	0	29	5	0	0	0	5	1	8	1	0	10	45
12:30	2	0	2	0	4	2	20	3	0	25	3	0	1	0	4	2	11	0	0	13	46
12:45	1	0	1	0	2	3	16	1	0	20	6	0	0	0	6	2	10	2	0	14	42
Total Volume	3	0	9	0	12	8	73	16	0	97	19	0	2	0	21	6	42	3	0	51	181
% App. Total	25	0	75	0		8.2	75.3	16.5	0		90.5	0	9.5	0		11.8	82.4	5.9	0		
PHF	.375	.000	.450	.000	.600	.667	.913	.571	.000	.836	.792	.000	.500	.000	.875	.750	.808	.375	.000	.911	.943

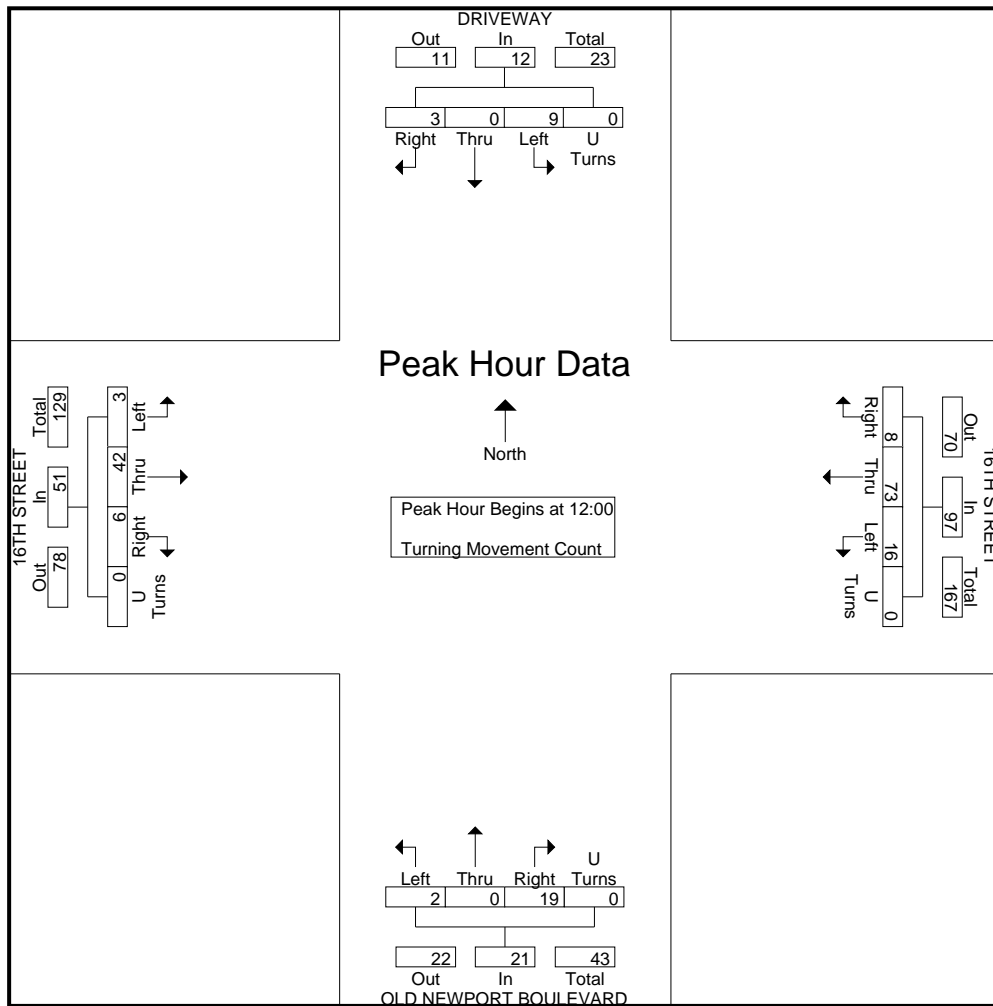

City: COSTA MESA
 N-S Direction: NEWPORT BOULEVARD
 E-W Direction: E. 16TH STREET

File Name : H2302005
 Site Code : 00000000
 Start Date : 2/4/2023
 Page No : 1

Groups Printed- Turning Movement Count

Start Time	NEWPORT BOULEVARD Southbound				E. 16TH STREET Westbound				NEWPORT BOULEVARD Northbound				E. 16TH STREET Eastbound				Int. Total
	Right	Thru	Left	U Turns	Right	Thru	Left	U Turns	Right	Thru	Left	U Turns	Right	Thru	Left	U Turns	
11:00	2	481	9	4	16	15	13	0	19	448	3	3	5	11	1	0	1030
11:15	1	495	5	8	16	15	22	0	16	463	2	0	2	9	6	0	1060
11:30	5	472	7	6	19	11	17	0	21	424	4	0	2	5	2	0	995
11:45	3	544	11	3	26	10	17	0	22	503	4	0	7	3	2	0	1155
Total	11	1992	32	21	77	51	69	0	78	1838	13	3	16	28	11	0	4240
12:00	5	458	8	3	20	11	24	0	21	475	5	1	5	11	11	0	1058
12:15	4	486	12	4	12	19	9	0	13	424	7	1	1	5	4	0	1001
12:30	2	496	9	3	11	15	21	0	21	408	3	1	6	7	5	0	1008
12:45	5	499	6	4	11	16	17	0	20	452	8	0	3	10	4	0	1055
Total	16	1939	35	14	54	61	71	0	75	1759	23	3	15	33	24	0	4122
Grand Total	27	3931	67	35	131	112	140	0	153	3597	36	6	31	61	35	0	8362
Apprch %	0.7	96.8	1.7	0.9	34.2	29.2	36.6	0	4	94.9	0.9	0.2	24.4	48	27.6	0	
Total %	0.3	47	0.8	0.4	1.6	1.3	1.7	0	1.8	43	0.4	0.1	0.4	0.7	0.4	0	

City: COSTA MESA
 N-S Direction: NEWPORT BOULEVARD
 E-W Direction: E. 16TH STREET

File Name : H2302005
 Site Code : 0000000
 Start Date : 2/4/2023
 Page No : 2

Start Time	NEWPORT BOULEVARD Southbound					E. 16TH STREET Westbound					NEWPORT BOULEVARD Northbound					E. 16TH STREET Eastbound					Int. Total
	Right	Thru	Left	U Turns	App. Total	Right	Thru	Left	U Turns	App. Total	Right	Thru	Left	U Turns	App. Total	Right	Thru	Left	U Turns	App. Total	
Peak Hour Analysis From 11:00 to 12:45 - Peak 1 of 1																					
Peak Hour for Entire Intersection Begins at 11:15																					
11:15	1	495	5	8	509	16	15	22	0	53	16	463	2	0	481	2	9	6	0	17	1060
11:30	5	472	7	6	490	19	11	17	0	47	21	424	4	0	449	2	5	2	0	9	995
11:45	3	544	11	3	561	26	10	17	0	53	22	503	4	0	529	7	3	2	0	12	1155
12:00	5	458	8	3	474	20	11	24	0	55	21	475	5	1	502	5	11	11	0	27	1058
Total Volume	14	1969	31	20	2034	81	47	80	0	208	80	1865	15	1	1961	16	28	21	0	65	4268
% App. Total	0.7	96.8	1.5	1		38.9	22.6	38.5	0		4.1	95.1	0.8	0.1		24.6	43.1	32.3	0		
PHF	.700	.905	.705	.625	.906	.779	.783	.833	.000	.945	.909	.927	.750	.250	.927	.571	.636	.477	.000	.602	.924

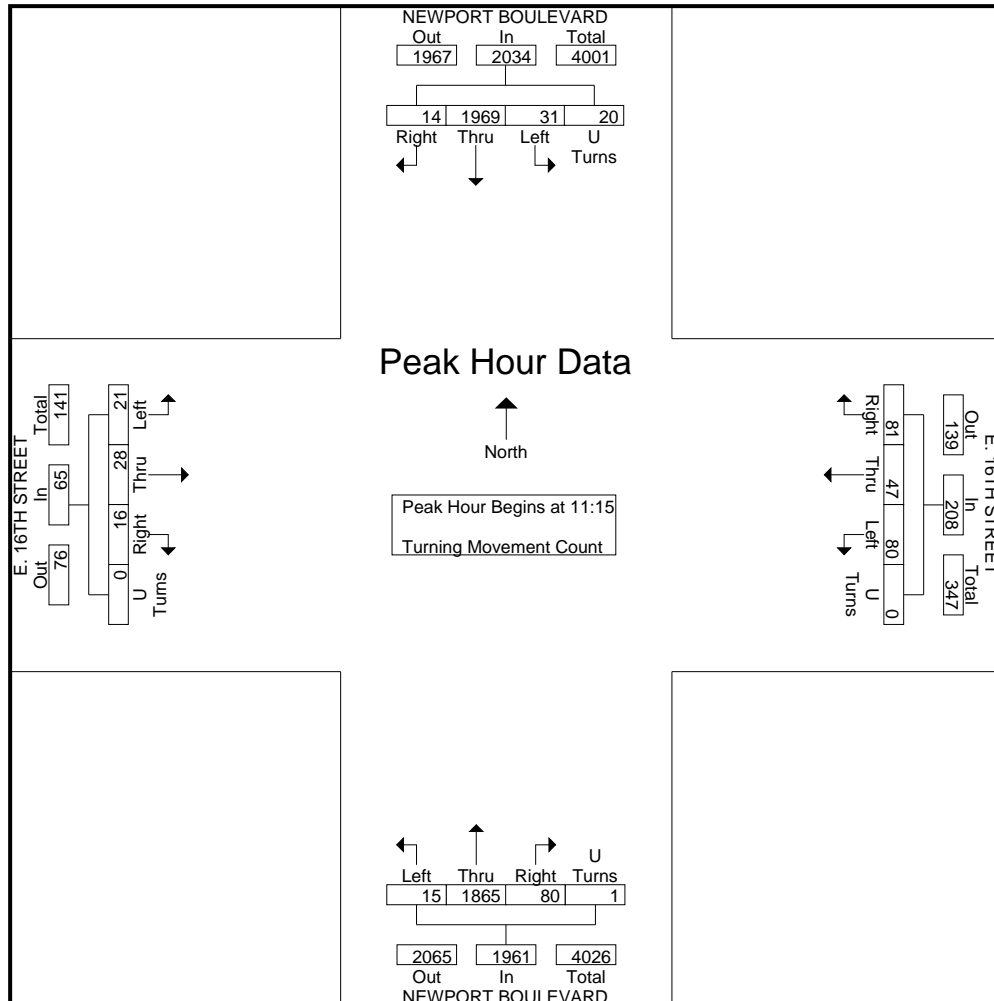

City: COSTA MESA
 N-S Direction: SUPERIOR AVENUE
 E-W Direction: INDUSTRIAL WAY

File Name : H2302015
 Site Code : 00000000
 Start Date : 2/4/2023
 Page No : 1

Groups Printed- Turning Movement Count

Start Time	SUPERIOR AVENUE Southbound				INDUSTRIAL WAY Westbound				SUPERIOR AVENUE Northbound				INDUSTRIAL WAY Eastbound				Int. Total
	Right	Thru	Left	U Turns	Right	Thru	Left	U Turns	Right	Thru	Left	U Turns	Right	Thru	Left	U Turns	
11:00	17	97	6	2	5	6	1	0	6	110	5	0	8	21	22	0	306
11:15	17	96	9	0	12	13	9	0	7	121	4	0	15	17	17	0	337
11:30	20	98	3	0	10	12	1	0	6	116	6	0	13	16	20	0	321
11:45	13	84	6	0	2	13	7	0	8	104	5	1	27	34	14	0	318
Total	67	375	24	2	29	44	18	0	27	451	20	1	63	88	73	0	1282
12:00	12	91	7	0	9	16	3	0	8	136	7	0	19	21	20	0	349
12:15	10	104	8	0	7	9	6	0	5	115	5	0	15	19	10	0	313
12:30	23	96	6	0	8	16	6	0	10	105	7	0	16	14	14	0	321
12:45	14	84	6	0	7	22	4	0	4	94	4	1	9	16	16	0	281
Total	59	375	27	0	31	63	19	0	27	450	23	1	59	70	60	0	1264
Grand Total	126	750	51	2	60	107	37	0	54	901	43	2	122	158	133	0	2546
Apprch %	13.6	80.7	5.5	0.2	29.4	52.5	18.1	0	5.4	90.1	4.3	0.2	29.5	38.3	32.2	0	
Total %	4.9	29.5	2	0.1	2.4	4.2	1.5	0	2.1	35.4	1.7	0.1	4.8	6.2	5.2	0	

City: COSTA MESA
 N-S Direction: SUPERIOR AVENUE
 E-W Direction: INDUSTRIAL WAY

File Name : H2302015
 Site Code : 0000000
 Start Date : 2/4/2023
 Page No : 2

Start Time	SUPERIOR AVENUE Southbound					INDUSTRIAL WAY Westbound					SUPERIOR AVENUE Northbound					INDUSTRIAL WAY Eastbound					Int. Total
	Right	Thru	Left	U Turns	App. Total	Right	Thru	Left	U Turns	App. Total	Right	Thru	Left	U Turns	App. Total	Right	Thru	Left	U Turns	App. Total	
Peak Hour Analysis From 11:00 to 12:45 - Peak 1 of 1																					
Peak Hour for Entire Intersection Begins at 11:15																					
11:15	17	96	9	0	122	12	13	9	0	34	7	121	4	0	132	15	17	17	0	49	337
11:30	20	98	3	0	121	10	12	1	0	23	6	116	6	0	128	13	16	20	0	49	321
11:45	13	84	6	0	103	2	13	7	0	22	8	104	5	1	118	27	34	14	0	75	318
12:00	12	91	7	0	110	9	16	3	0	28	8	136	7	0	151	19	21	20	0	60	349
Total Volume	62	369	25	0	456	33	54	20	0	107	29	477	22	1	529	74	88	71	0	233	1325
% App. Total	13.6	80.9	5.5	0		30.8	50.5	18.7	0		5.5	90.2	4.2	0.2		31.8	37.8	30.5	0		
PHF	.775	.941	.694	.000	.934	.688	.844	.556	.000	.787	.906	.877	.786	.250	.876	.685	.647	.888	.000	.777	.949

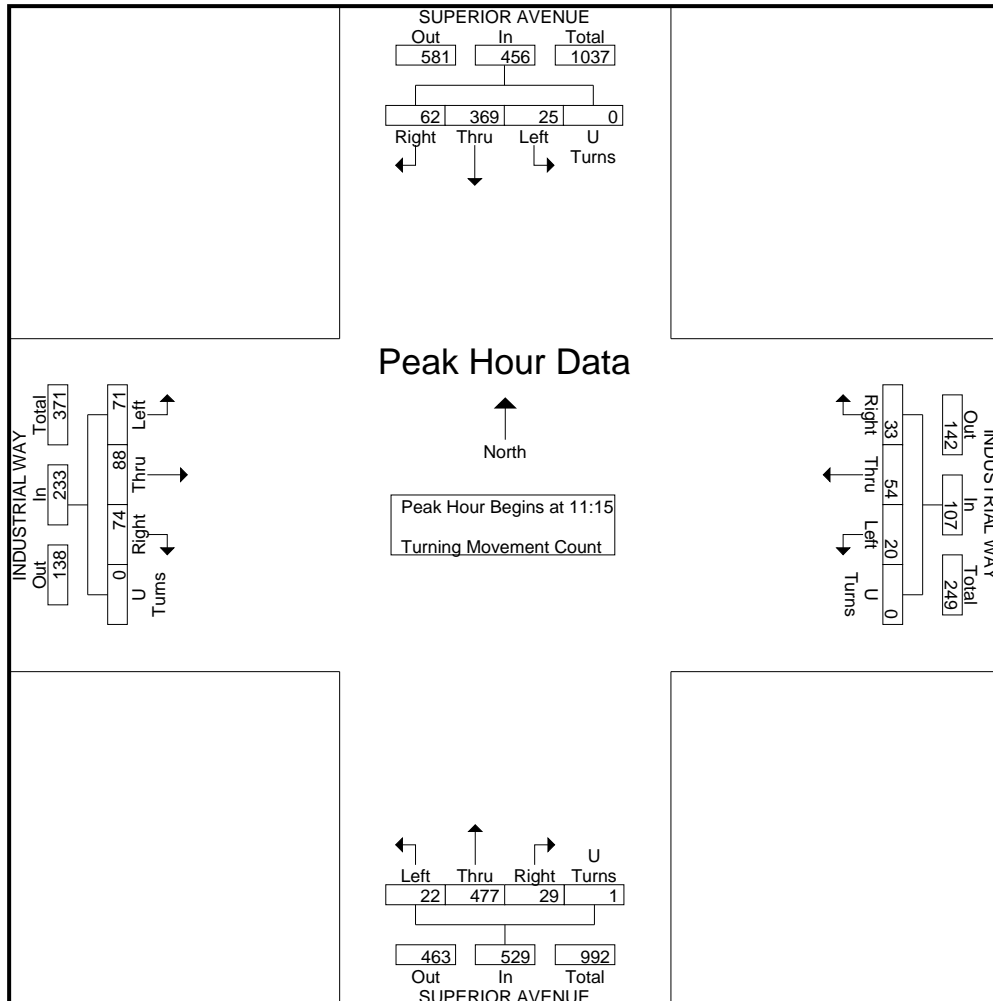

City: COSTA MESA
 N-S Direction: OLD NEWPORT BOULEVARD
 E-W Direction: INDUSTRIAL WAY

File Name : H2302007
 Site Code : 00000000
 Start Date : 2/4/2023
 Page No : 1

Groups Printed- Turning Movement Count

Start Time	OLD NEWPORT BOULEVARD Southbound				INDUSTRIAL WAY Westbound				DRIVEWAY Northbound				INDUSTRIAL WAY Eastbound				Int. Total
	Right	Thru	Left	U Turns	Right	Thru	Left	U Turns	Right	Thru	Left	U Turns	Right	Thru	Left	U Turns	
11:00	1	0	2	0	2	12	5	0	3	0	0	0	1	28	0	0	54
11:15	3	0	1	0	4	27	3	0	4	0	3	0	3	30	1	0	79
11:30	0	0	4	0	2	17	3	0	5	0	2	0	2	26	0	0	61
11:45	1	0	0	0	0	16	10	0	3	0	6	0	4	45	0	0	85
Total	5	0	7	0	8	72	21	0	15	0	11	0	10	129	1	0	279
12:00	3	0	2	0	2	22	3	0	6	0	0	0	5	30	0	0	73
12:15	2	0	0	0	1	19	6	0	6	0	4	0	1	32	0	0	71
12:30	6	0	1	0	2	23	5	0	6	0	3	0	6	21	2	0	75
12:45	3	0	0	0	2	28	5	0	9	0	1	0	2	26	1	0	77
Total	14	0	3	0	7	92	19	0	27	0	8	0	14	109	3	0	296
Grand Total	19	0	10	0	15	164	40	0	42	0	19	0	24	238	4	0	575
Apprch %	65.5	0	34.5	0	6.8	74.9	18.3	0	68.9	0	31.1	0	9	89.5	1.5	0	
Total %	3.3	0	1.7	0	2.6	28.5	7	0	7.3	0	3.3	0	4.2	41.4	0.7	0	

City: COSTA MESA
 N-S Direction: OLD NEWPORT BOULEVARD
 E-W Direction: INDUSTRIAL WAY

File Name : H2302007
 Site Code : 0000000
 Start Date : 2/4/2023
 Page No : 2

Start Time	OLD NEWPORT BOULEVARD Southbound					INDUSTRIAL WAY Westbound					DRIVEWAY Northbound					INDUSTRIAL WAY Eastbound					Int. Total
	Right	Thru	Left	U Turns	App. Total	Right	Thru	Left	U Turns	App. Total	Right	Thru	Left	U Turns	App. Total	Right	Thru	Left	U Turns	App. Total	
Peak Hour Analysis From 11:00 to 12:45 - Peak 1 of 1																					
Peak Hour for Entire Intersection Begins at 11:45																					
11:45	1	0	0	0	1	0	16	10	0	26	3	0	6	0	9	4	45	0	0	49	85
12:00	3	0	2	0	5	2	22	3	0	27	6	0	0	0	6	5	30	0	0	35	73
12:15	2	0	0	0	2	1	19	6	0	26	6	0	4	0	10	1	32	0	0	33	71
12:30	6	0	1	0	7	2	23	5	0	30	6	0	3	0	9	6	21	2	0	29	75
Total Volume	12	0	3	0	15	5	80	24	0	109	21	0	13	0	34	16	128	2	0	146	304
% App. Total	80	0	20	0		4.6	73.4	22	0		61.8	0	38.2	0		11	87.7	1.4	0		
PHF	.500	.000	.375	.000	.536	.625	.870	.600	.000	.908	.875	.000	.542	.000	.850	.667	.711	.250	.000	.745	.894

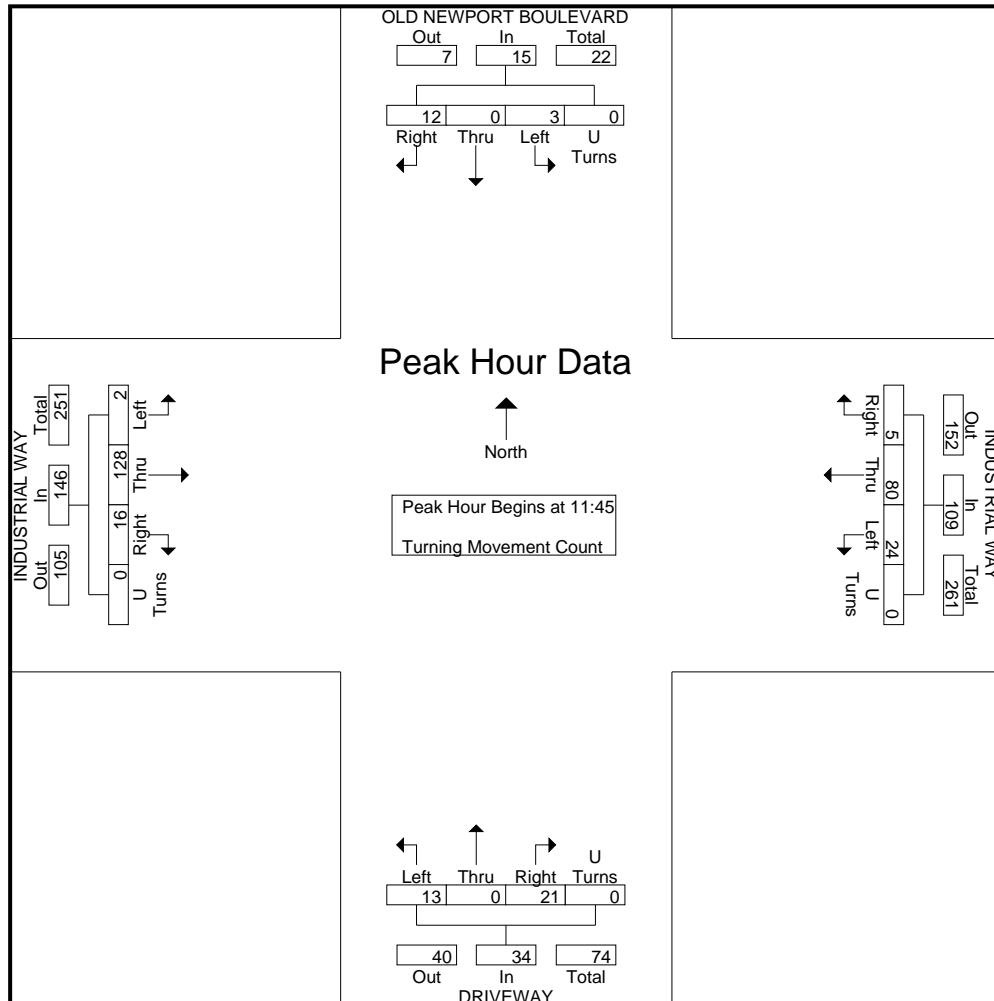

City: COSTA MESA
 N-S Direction: NEWPORT BOULEVARD
 E-W Direction: INDUSTRIAL WAY

File Name : H2302009
 Site Code : 00000000
 Start Date : 2/4/2023
 Page No : 1

Groups Printed- Turning Movement Count

Start Time	NEWPORT BOULEVARD Southbound				INDUSTRIAL WAY Westbound				NEWPORT BOULEVARD Northbound				INDUSTRIAL WAY Eastbound				Int. Total
	Right	Thru	Left	U Turns	Right	Thru	Left	U Turns	Right	Thru	Left	U Turns	Right	Thru	Left	U Turns	
11:00	6	507	7	0	22	6	1	0	1	445	8	1	15	7	12	0	1038
11:15	13	479	19	1	21	7	2	0	6	444	10	1	16	11	10	0	1040
11:30	7	481	7	0	15	9	2	0	4	463	8	0	14	11	4	0	1025
11:45	8	527	10	0	17	15	3	0	2	464	3	0	19	19	12	0	1099
Total	34	1994	43	1	75	37	8	0	13	1816	29	2	64	48	38	0	4202
12:00	9	486	6	0	11	10	4	0	4	499	3	1	17	11	8	0	1069
12:15	8	477	19	0	18	17	2	0	7	421	8	1	17	11	12	0	1018
12:30	8	491	10	0	14	13	2	0	1	418	4	0	12	12	12	0	997
12:45	9	492	11	0	16	16	2	0	0	430	8	0	8	12	7	0	1011
Total	34	1946	46	0	59	56	10	0	12	1768	23	2	54	46	39	0	4095
Grand Total	68	3940	89	1	134	93	18	0	25	3584	52	4	118	94	77	0	8297
Apprch %	1.7	96.1	2.2	0	54.7	38	7.3	0	0.7	97.8	1.4	0.1	40.8	32.5	26.6	0	
Total %	0.8	47.5	1.1	0	1.6	1.1	0.2	0	0.3	43.2	0.6	0	1.4	1.1	0.9	0	

City: COSTA MESA
 N-S Direction: NEWPORT BOULEVARD
 E-W Direction: INDUSTRIAL WAY

File Name : H2302009
 Site Code : 0000000
 Start Date : 2/4/2023
 Page No : 2

Start Time	NEWPORT BOULEVARD Southbound					INDUSTRIAL WAY Westbound					NEWPORT BOULEVARD Northbound					INDUSTRIAL WAY Eastbound					Int. Total
	Right	Thru	Left	U Turns	App. Total	Right	Thru	Left	U Turns	App. Total	Right	Thru	Left	U Turns	App. Total	Right	Thru	Left	U Turns	App. Total	
Peak Hour Analysis From 11:00 to 12:45 - Peak 1 of 1																					
Peak Hour for Entire Intersection Begins at 11:15																					
11:15	13	479	19	1	512	21	7	2	0	30	6	444	10	1	461	16	11	10	0	37	1040
11:30	7	481	7	0	495	15	9	2	0	26	4	463	8	0	475	14	11	4	0	29	1025
11:45	8	527	10	0	545	17	15	3	0	35	2	464	3	0	469	19	19	12	0	50	1099
12:00	9	486	6	0	501	11	10	4	0	25	4	499	3	1	507	17	11	8	0	36	1069
Total Volume	37	1973	42	1	2053	64	41	11	0	116	16	1870	24	2	1912	66	52	34	0	152	4233
% App. Total	1.8	96.1	2	0		55.2	35.3	9.5	0		0.8	97.8	1.3	0.1		43.4	34.2	22.4	0		
PHF	.712	.936	.553	.250	.942	.762	.683	.688	.000	.829	.667	.937	.600	.500	.943	.868	.684	.708	.000	.760	.963

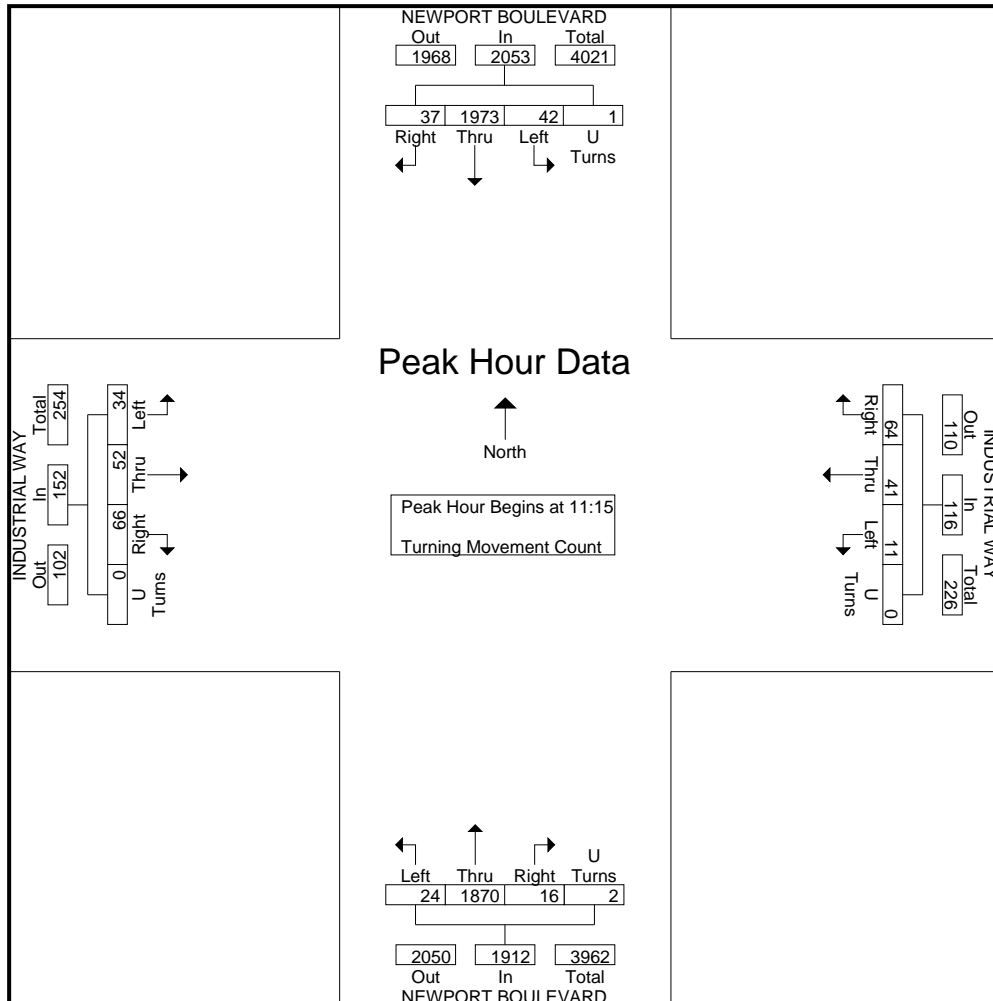

Appendix C LOS WORKSHEETS



EXISTING CONDITIONS

MID-DAY

Existing Conditions - Mid-Day
1: Superior Ave & 17th St

Lanes, Volumes, Timings
Synchro 11 Report

Lane Group	EBL	EBT	EBR	WBL	WBT	WBR	NBL	NBT	NBR	SBL	SBT	SBR
Lane Configurations												
Traffic Volume (vph)	53	585	73	216	457	72	109	156	523	101	316	98
Future Volume (vph)	53	585	73	216	457	72	109	156	523	101	316	98
Ideal Flow (vphpl)	1900	1900	1900	1900	1900	1900	1900	1900	1900	1900	1900	1900
Storage Length (ft)	100		250	0		0	80		0	90		0
Storage Lanes	1		1	1		0	1		1	1		0
Taper Length (ft)	25			25			25			25		
Satd. Flow (prot)	1770	3539	1583	1770	3468	0	1770	1623	1504	1770	3412	0
Flt Permitted	0.950			0.294			0.407			0.260		
Satd. Flow (perm)	1770	3539	1583	548	3468	0	758	1623	1504	484	3412	0
Right Turn on Red			Yes			Yes			Yes			Yes
Satd. Flow (RTOR)			214		25			75	333		50	
Link Speed (mph)		35			30			35			35	
Link Distance (ft)		556			357			606			247	
Travel Time (s)		10.8			8.1			11.8			4.8	
Peak Hour Factor	0.99	0.99	0.99	0.99	0.99	0.99	0.99	0.99	0.99	0.99	0.99	0.99
Shared Lane Traffic (%)									37%			
Lane Group Flow (vph)	54	591	74	218	535	0	110	353	333	102	418	0
Turn Type	Prot	NA	Perm	pm+pt	NA		pm+pt	NA	Perm	pm+pt	NA	
Protected Phases	1	6		5	2		3	8		7	4	
Permitted Phases			6	2			8		8	4		
Total Split (s)	12.0	22.0	22.0	20.0	30.0		12.0	21.0	21.0	12.0	21.0	
Total Lost Time (s)	4.2	5.1	5.1	4.2	5.1		4.2	5.1	5.1	4.2	5.1	
Act Effct Green (s)	6.3	26.5	26.5	41.0	33.6		21.8	15.2	15.2	22.2	15.4	
Actuated g/C Ratio	0.08	0.35	0.35	0.55	0.45		0.29	0.20	0.20	0.30	0.21	
v/c Ratio	0.36	0.47	0.11	0.48	0.34		0.35	0.91	0.58	0.39	0.56	
Control Delay	39.1	22.6	0.3	13.7	16.2		19.3	52.2	7.9	20.3	26.6	
Queue Delay	0.0	0.0	0.0	0.0	0.0		0.0	0.0	0.0	0.0	0.0	
Total Delay	39.1	22.6	0.3	13.7	16.2		19.3	52.2	7.9	20.3	26.6	
LOS	D	C	A	B	B		B	D	A	C	C	
Approach Delay		21.5			15.5			29.1			25.3	
Approach LOS		C			B			C			C	

Intersection Summary

Area Type: Other
 Cycle Length: 75
 Actuated Cycle Length: 75
 Offset: 28 (37%), Referenced to phase 2:WBTL and 6:EBT, Start of Green
 Control Type: Actuated-Coordinated
 Maximum v/c Ratio: 0.91
 Intersection Signal Delay: 22.8 Intersection LOS: C
 Intersection Capacity Utilization 68.1% ICU Level of Service C
 Analysis Period (min) 15

Splits and Phases: 1: Superior Ave & 17th St

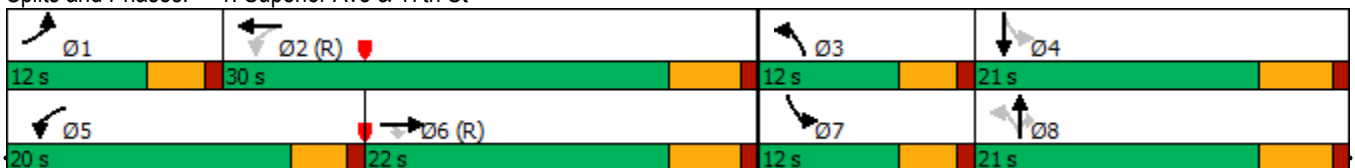

Intersection						
Int Delay, s/veh	1.1					
Movement	WBL	WBR	NBT	NBR	SBL	SBT
Lane Configurations	↔		↕↔		↕	↕↕
Traffic Vol, veh/h	34	47	721	18	52	643
Future Vol, veh/h	34	47	721	18	52	643
Conflicting Peds, #/hr	0	0	0	0	0	0
Sign Control	Stop	Stop	Free	Free	Free	Free
RT Channelized	-	None	-	None	-	None
Storage Length	0	-	-	-	65	-
Veh in Median Storage, #	0	-	0	-	-	0
Grade, %	0	-	0	-	-	0
Peak Hour Factor	97	97	97	97	97	97
Heavy Vehicles, %	2	2	2	2	2	2
Mvmt Flow	35	48	743	19	54	663

Major/Minor	Minor1	Major1	Major2		
Conflicting Flow All	1193	381	0	0	762
Stage 1	753	-	-	-	-
Stage 2	440	-	-	-	-
Critical Hdwy	6.84	6.94	-	-	4.14
Critical Hdwy Stg 1	5.84	-	-	-	-
Critical Hdwy Stg 2	5.84	-	-	-	-
Follow-up Hdwy	3.52	3.32	-	-	2.22
Pot Cap-1 Maneuver	180	617	-	-	846
Stage 1	426	-	-	-	-
Stage 2	616	-	-	-	-
Platoon blocked, %			-	-	-
Mov Cap-1 Maneuver	168	617	-	-	846
Mov Cap-2 Maneuver	298	-	-	-	-
Stage 1	426	-	-	-	-
Stage 2	577	-	-	-	-

Approach	WB	NB	SB
HCM Control Delay, s	15.5	0	0.7
HCM LOS	C		

Minor Lane/Major Mvmt	NBT	NBRWBLn1	SBL	SBT
Capacity (veh/h)	-	-	426	846
HCM Lane V/C Ratio	-	-	0.196	0.063
HCM Control Delay (s)	-	-	15.5	9.5
HCM Lane LOS	-	-	C	A
HCM 95th %tile Q(veh)	-	-	0.7	0.2

Existing Conditions - Mid-Day
 3: Old Newport Blvd (W) & E 16th St

HCM 6th TWSC
 Synchro 11 Report

Intersection												
Int Delay, s/veh	2.4											
Movement	EBL	EBT	EBR	WBL	WBT	WBR	NBL	NBT	NBR	SBL	SBT	SBR
Lane Configurations		↔			↔			↔			↔	
Traffic Vol, veh/h	3	55	9	21	66	7	4	0	15	9	3	0
Future Vol, veh/h	3	55	9	21	66	7	4	0	15	9	3	0
Conflicting Peds, #/hr	0	0	0	0	0	0	0	0	0	0	0	0
Sign Control	Free	Free	Free	Free	Free	Free	Stop	Stop	Stop	Stop	Stop	Stop
RT Channelized	-	-	None	-	-	None	-	-	None	-	-	None
Storage Length	-	-	-	-	-	-	-	-	-	-	-	-
Veh in Median Storage, #	-	0	-	-	0	-	-	0	-	-	0	-
Grade, %	-	0	-	-	0	-	-	0	-	-	0	-
Peak Hour Factor	91	91	91	91	91	91	91	91	91	91	91	91
Heavy Vehicles, %	2	2	2	2	2	2	2	2	2	2	2	2
Mvmt Flow	3	60	10	23	73	8	4	0	16	10	3	0

Major/Minor	Major1			Major2			Minor1			Minor2		
Conflicting Flow All	81	0	0	70	0	0	196	198	65	202	199	77
Stage 1	-	-	-	-	-	-	71	71	-	123	123	-
Stage 2	-	-	-	-	-	-	125	127	-	79	76	-
Critical Hdwy	4.12	-	-	4.12	-	-	7.12	6.52	6.22	7.12	6.52	6.22
Critical Hdwy Stg 1	-	-	-	-	-	-	6.12	5.52	-	6.12	5.52	-
Critical Hdwy Stg 2	-	-	-	-	-	-	6.12	5.52	-	6.12	5.52	-
Follow-up Hdwy	2.218	-	-	2.218	-	-	3.518	4.018	3.318	3.518	4.018	3.318
Pot Cap-1 Maneuver	1517	-	-	1531	-	-	763	698	999	756	697	984
Stage 1	-	-	-	-	-	-	939	836	-	881	794	-
Stage 2	-	-	-	-	-	-	879	791	-	930	832	-
Platoon blocked, %	-	-	-	-	-	-	-	-	-	-	-	-
Mov Cap-1 Maneuver	1517	-	-	1531	-	-	750	685	999	733	684	984
Mov Cap-2 Maneuver	-	-	-	-	-	-	750	685	-	733	684	-
Stage 1	-	-	-	-	-	-	937	834	-	879	781	-
Stage 2	-	-	-	-	-	-	861	778	-	913	830	-

Approach	EB			WB			NB			SB		
HCM Control Delay, s	0.3			1.7			8.9			10.1		
HCM LOS							A			B		

Minor Lane/Major Mvmt	NBLn1	EBL	EBT	EBR	WBL	WBT	WBR	SBLn1
Capacity (veh/h)	934	1517	-	-	1531	-	-	720
HCM Lane V/C Ratio	0.022	0.002	-	-	0.015	-	-	0.018
HCM Control Delay (s)	8.9	7.4	-	-	7.4	0	-	10.1
HCM Lane LOS	A	A	-	-	A	A	-	B
HCM 95th %tile Q(veh)	0.1	0	-	-	0	-	-	0.1

Existing Conditions - Mid-Day
4: Newport Blvd & E 16th St



Lane Group	EBL	EBT	EBR	WBL	WBT	WBR	NBL	NBT	NBR	SBL	SBT	SBR
Lane Configurations		↕			↕		↕	↑↑↑		↕	↑↑↑	↕
Traffic Volume (vph)	31	23	12	67	37	76	31	1730	86	80	1717	28
Future Volume (vph)	31	23	12	67	37	76	31	1730	86	80	1717	28
Ideal Flow (vphpl)	1900	1900	1900	1900	1900	1900	1900	1900	1900	1900	1900	1900
Storage Length (ft)	0		0	0		0	95		0	85		55
Storage Lanes	0		0	0		0	1		0	1		1
Taper Length (ft)	25			25			25			25		
Satd. Flow (prot)	0	1776	0	0	1725	0	1770	5050	0	1770	5085	1583
Flt Permitted		0.675			0.858		0.950			0.950		
Satd. Flow (perm)	0	1227	0	0	1507	0	1770	5050	0	1770	5085	1583
Right Turn on Red			Yes			Yes			No			Yes
Satd. Flow (RTOR)		8			26							57
Link Speed (mph)		25			25			50			50	
Link Distance (ft)		160			479			1146			979	
Travel Time (s)		4.4			13.1			15.6			13.4	
Peak Hour Factor	0.97	0.97	0.97	0.97	0.97	0.97	0.97	0.97	0.97	0.97	0.97	0.97
Shared Lane Traffic (%)												
Lane Group Flow (vph)	0	68	0	0	185	0	32	1873	0	82	1770	29
Turn Type	Perm	NA		Perm	NA		Prot	NA		Prot	NA	Perm
Protected Phases		4			8		5	2		1	6	
Permitted Phases	4			8								6
Total Split (s)	45.0	45.0		45.0	45.0		15.2	75.7		18.2	75.7	75.7
Total Lost Time (s)		6.0			6.0		4.2	5.7		4.2	5.7	5.7
Act Effct Green (s)		19.6			19.6		9.2	92.0		11.4	99.5	99.5
Actuated g/C Ratio		0.14			0.14		0.07	0.66		0.08	0.72	0.72
v/c Ratio		0.38			0.79		0.28	0.56		0.57	0.49	0.03
Control Delay		51.6			71.3		68.0	14.5		76.3	10.7	0.5
Queue Delay		0.0			0.0		0.0	0.0		0.0	0.0	0.0
Total Delay		51.6			71.3		68.0	14.5		76.3	10.7	0.5
LOS		D			E		E	B		E	B	A
Approach Delay		51.6			71.3			15.4			13.4	
Approach LOS		D			E			B			B	

Intersection Summary
 Area Type: Other
 Cycle Length: 138.9
 Actuated Cycle Length: 138.9
 Offset: 102 (73%), Referenced to phase 2:NBT and 6:SBT, Start of Green
 Control Type: Actuated-Coordinated
 Maximum v/c Ratio: 0.79
 Intersection Signal Delay: 17.6 Intersection LOS: B
 Intersection Capacity Utilization 68.2% ICU Level of Service C
 Analysis Period (min) 15

Splits and Phases: 4: Newport Blvd & E 16th St

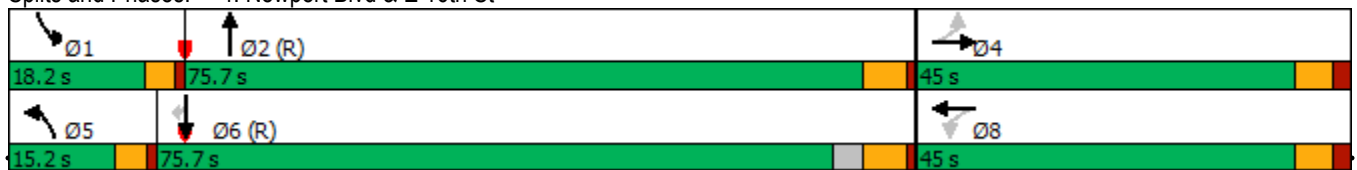

Existing Conditions - Mid-Day
5: Superior Ave & W 16th St/Industrial Way

Lanes, Volumes, Timings
Synchro 11 Report

Lane Group	EBL	EBT	EBR	WBL	WBT	WBR	NBL	NBT	NBR	SBL	SBT	SBR
Lane Configurations												
Traffic Volume (vph)	83	85	52	45	74	30	53	554	84	29	508	86
Future Volume (vph)	83	85	52	45	74	30	53	554	84	29	508	86
Ideal Flow (vphpl)	1900	1900	1900	1900	1900	1900	1900	1900	1900	1900	1900	1900
Storage Length (ft)	0		0	0		0	100		110	100		0
Storage Lanes	1		0	0		0	1		1	1		0
Taper Length (ft)	25			25			25			25		
Satd. Flow (prot)	1770	1757	0	0	1785	0	1770	3539	1583	1770	3461	0
Flt Permitted	0.950				0.985		0.315			0.346		
Satd. Flow (perm)	1770	1757	0	0	1785	0	587	3539	1583	645	3461	0
Right Turn on Red			Yes			Yes			Yes			No
Satd. Flow (RTOR)		31			10				64			
Link Speed (mph)		30			30			40				35
Link Distance (ft)		216			687			694				1138
Travel Time (s)		4.9			15.6			11.8				22.2
Peak Hour Factor	0.97	0.97	0.97	0.97	0.97	0.97	0.97	0.97	0.97	0.97	0.97	0.97
Shared Lane Traffic (%)												
Lane Group Flow (vph)	86	142	0	0	153	0	55	571	87	30	613	0
Turn Type	Split	NA		Split	NA		Perm	NA	Perm	Perm	NA	
Protected Phases	6	6		2	2			3			3	
Permitted Phases							3		3	3		
Total Split (s)	56.1	56.1		35.1	35.1		30.9	30.9	30.9	30.9	30.9	
Total Lost Time (s)	5.1	5.1			5.1		5.9	5.9	5.9	5.9	5.9	
Act Effct Green (s)	9.5	9.5			30.0		25.0	25.0	25.0	25.0	25.0	
Actuated g/C Ratio	0.12	0.12			0.37		0.31	0.31	0.31	0.31	0.31	
v/c Ratio	0.41	0.61			0.23		0.30	0.52	0.16	0.15	0.57	
Control Delay	38.8	37.3			18.0		28.0	25.4	9.6	23.8	26.3	
Queue Delay	0.0	0.0			0.0		0.0	0.0	0.0	0.0	0.0	
Total Delay	38.8	37.3			18.0		28.0	25.4	9.6	23.8	26.3	
LOS	D	D			B		C	C	A	C	C	
Approach Delay		37.9			18.0			23.7			26.2	
Approach LOS		D			B			C			C	

Intersection Summary

Area Type: Other
 Cycle Length: 122.1
 Actuated Cycle Length: 80.7
 Control Type: Actuated-Uncoordinated
 Maximum v/c Ratio: 0.61
 Intersection Signal Delay: 26.0
 Intersection Capacity Utilization 54.3%
 Analysis Period (min) 15
 Intersection LOS: C
 ICU Level of Service A

Splits and Phases: 5: Superior Ave & W 16th St/Industrial Way



Existing Conditions - Mid-Day
6: Industrial Way & Old Newport Blvd (W)

Intersection												
Int Delay, s/veh	3.1											
Movement	EBL	EBT	EBR	WBL	WBT	WBR	NBL	NBT	NBR	SBL	SBT	SBR
Lane Configurations		↕			↕			↕			↕	
Traffic Vol, veh/h	8	171	23	41	124	6	22	2	48	10	4	11
Future Vol, veh/h	8	171	23	41	124	6	22	2	48	10	4	11
Conflicting Peds, #/hr	0	0	0	0	0	0	0	0	0	0	0	0
Sign Control	Free	Free	Free	Free	Free	Free	Stop	Stop	Stop	Stop	Stop	Stop
RT Channelized	-	-	None	-	-	None	-	-	None	-	-	None
Storage Length	-	-	-	-	-	-	-	-	-	-	-	-
Veh in Median Storage, #	-	0	-	-	0	-	-	0	-	-	0	-
Grade, %	-	0	-	-	0	-	-	0	-	-	0	-
Peak Hour Factor	95	95	95	95	95	95	95	95	95	95	95	95
Heavy Vehicles, %	2	2	2	2	2	2	2	2	2	2	2	2
Mvmt Flow	8	180	24	43	131	6	23	2	51	11	4	12

Major/Minor	Major1			Major2			Minor1			Minor2		
Conflicting Flow All	137	0	0	204	0	0	436	431	192	455	440	134
Stage 1	-	-	-	-	-	-	208	208	-	220	220	-
Stage 2	-	-	-	-	-	-	228	223	-	235	220	-
Critical Hdwy	4.12	-	-	4.12	-	-	7.12	6.52	6.22	7.12	6.52	6.22
Critical Hdwy Stg 1	-	-	-	-	-	-	6.12	5.52	-	6.12	5.52	-
Critical Hdwy Stg 2	-	-	-	-	-	-	6.12	5.52	-	6.12	5.52	-
Follow-up Hdwy	2.218	-	-	2.218	-	-	3.518	4.018	3.318	3.518	4.018	3.318
Pot Cap-1 Maneuver	1447	-	-	1368	-	-	531	517	850	515	511	915
Stage 1	-	-	-	-	-	-	794	730	-	782	721	-
Stage 2	-	-	-	-	-	-	775	719	-	768	721	-
Platoon blocked, %	-	-	-	-	-	-	-	-	-	-	-	-
Mov Cap-1 Maneuver	1447	-	-	1368	-	-	505	496	850	468	491	915
Mov Cap-2 Maneuver	-	-	-	-	-	-	505	496	-	468	491	-
Stage 1	-	-	-	-	-	-	789	726	-	777	696	-
Stage 2	-	-	-	-	-	-	735	695	-	716	717	-

Approach	EB			WB			NB			SB		
HCM Control Delay, s	0.3			1.9			10.8			11.3		
HCM LOS							B			B		

Minor Lane/Major Mvmt	NBLn1	EBL	EBT	EBR	WBL	WBT	WBR	SBLn1
Capacity (veh/h)	692	1447	-	-	1368	-	-	602
HCM Lane V/C Ratio	0.11	0.006	-	-	0.032	-	-	0.044
HCM Control Delay (s)	10.8	7.5	0	-	7.7	0	-	11.3
HCM Lane LOS	B	A	A	-	A	A	-	B
HCM 95th %tile Q(veh)	0.4	0	-	-	0.1	-	-	0.1

Existing Conditions - Mid-Day
7: Newport Blvd & Industrial Way

Lanes, Volumes, Timings
Synchro 11 Report



Lane Group	EBL	EBT	EBR	WBL	WBT	WBR	NBL	NBT	NBR	SBL	SBT	SBR
Lane Configurations		↖	↗	↖	↖	↗	↖	↖↗↘		↖	↖↗↘	
Traffic Volume (vph)	62	49	114	10	69	97	29	1650	14	111	1663	53
Future Volume (vph)	62	49	114	10	69	97	29	1650	14	111	1663	53
Ideal Flow (vphpl)	1900	1900	1900	1900	1900	1900	1900	1900	1900	1900	1900	1900
Storage Length (ft)	0		0	0		0	90		0	95		0
Storage Lanes	0		1	1		1	1		0	1		0
Taper Length (ft)	25			25			25			25		
Satd. Flow (prot)	0	1812	1583	1770	1863	1583	1770	5080	0	1770	5060	0
Flt Permitted		0.751		0.501			0.950			0.950		
Satd. Flow (perm)	0	1399	1583	933	1863	1583	1770	5080	0	1770	5060	0
Right Turn on Red			Yes			Yes			Yes			Yes
Satd. Flow (RTOR)			119			101		1				5
Link Speed (mph)		30			30			50				50
Link Distance (ft)		175			191			846				1146
Travel Time (s)		4.0			4.3			11.5				15.6
Peak Hour Factor	0.96	0.96	0.96	0.96	0.96	0.96	0.96	0.96	0.96	0.96	0.96	0.96
Shared Lane Traffic (%)												
Lane Group Flow (vph)	0	116	119	10	72	101	30	1734	0	116	1787	0
Turn Type	Perm	NA	Perm	Perm	NA	Perm	Prot	NA		Prot	NA	
Protected Phases		4			8		5	2		1	6	
Permitted Phases	4		4	8		8						
Total Split (s)	40.6	40.6	40.6	40.6	40.6	40.6	15.2	76.4		26.2	76.4	
Total Lost Time (s)		4.6	4.6	4.6	4.6	4.6	4.2	6.4		4.2	6.4	
Act Effct Green (s)		15.7	15.7	15.7	15.7	15.7	9.0	98.7		13.5	108.5	
Actuated g/C Ratio		0.11	0.11	0.11	0.11	0.11	0.06	0.69		0.09	0.76	
v/c Ratio		0.76	0.43	0.10	0.35	0.38	0.27	0.50		0.69	0.47	
Control Delay		90.1	13.7	56.6	62.3	13.9	70.4	12.0		83.6	8.1	
Queue Delay		0.0	0.0	0.0	0.0	0.0	0.0	0.0		0.0	0.0	
Total Delay		90.1	13.7	56.6	62.3	13.9	70.4	12.0		83.6	8.1	
LOS		F	B	E	E	B	E	B		F	A	
Approach Delay		51.4			35.3			13.0			12.7	
Approach LOS		D			D			B			B	

Intersection Summary

Area Type: Other
 Cycle Length: 143.2
 Actuated Cycle Length: 143.2
 Offset: 90 (63%), Referenced to phase 2:NBT and 6:SBT, Start of Green
 Control Type: Actuated-Coordinated
 Maximum v/c Ratio: 0.76
 Intersection Signal Delay: 16.0
 Intersection LOS: B
 Intersection Capacity Utilization 66.2%
 ICU Level of Service C
 Analysis Period (min) 15

Splits and Phases: 7: Newport Blvd & Industrial Way



EXISTING CONDITIONS

PM PEAK HOUR

Existing Conditions - PM Peak Hour
1: Superior Ave & 17th St

Lanes, Volumes, Timings
Synchro 11 Report

Lane Group	EBL	EBT	EBR	WBL	WBT	WBR	NBL	NBT	NBR	SBL	SBT	SBR
Lane Configurations												
Traffic Volume (vph)	35	513	66	237	429	65	107	152	550	72	302	110
Future Volume (vph)	35	513	66	237	429	65	107	152	550	72	302	110
Ideal Flow (vphpl)	1900	1900	1900	1900	1900	1900	1900	1900	1900	1900	1900	1900
Storage Length (ft)	100		250	0		0	80		0	90		0
Storage Lanes	1		1	1		0	1		1	1		0
Taper Length (ft)	25			25			25			25		
Satd. Flow (prot)	1770	3539	1583	1770	3468	0	1770	1616	1504	1770	3398	0
Flt Permitted	0.950			0.306			0.371			0.223		
Satd. Flow (perm)	1770	3539	1583	570	3468	0	691	1616	1504	415	3398	0
Right Turn on Red			Yes			Yes			Yes			Yes
Satd. Flow (RTOR)			200		23			80	371			60
Link Speed (mph)		35			30			35			35	
Link Distance (ft)		556			357			606			247	
Travel Time (s)		10.8			8.1			11.8			4.8	
Peak Hour Factor	0.92	0.92	0.92	0.92	0.92	0.92	0.92	0.92	0.92	0.92	0.92	0.92
Shared Lane Traffic (%)									38%			
Lane Group Flow (vph)	38	558	72	258	537	0	116	392	371	78	448	0
Turn Type	Prot	NA	Perm	pm+pt	NA		pm+pt	NA	Perm	pm+pt	NA	
Protected Phases	1	6		5	2		3	8		7	4	
Permitted Phases			6	2			8		8	4		
Total Split (s)	12.0	24.0	24.0	21.0	33.0		12.0	23.0	23.0	12.0	23.0	
Total Lost Time (s)	4.2	5.1	5.1	4.2	5.1		4.2	5.1	5.1	4.2	5.1	
Act Effct Green (s)	6.0	27.5	27.5	43.6	36.2		24.8	18.1	18.1	24.4	17.9	
Actuated g/C Ratio	0.08	0.34	0.34	0.54	0.45		0.31	0.23	0.23	0.30	0.22	
v/c Ratio	0.29	0.46	0.11	0.54	0.34		0.38	0.92	0.59	0.33	0.56	
Control Delay	40.1	24.1	0.3	15.3	16.5		20.6	53.7	7.5	20.0	26.6	
Queue Delay	0.0	0.0	0.0	0.0	0.0		0.0	0.0	0.0	0.0	0.0	
Total Delay	40.1	24.1	0.3	15.3	16.5		20.6	53.7	7.5	20.0	26.6	
LOS	D	C	A	B	B		C	D	A	B	C	
Approach Delay		22.5			16.1			29.8			25.6	
Approach LOS		C			B			C			C	

Intersection Summary

Area Type: Other
 Cycle Length: 80
 Actuated Cycle Length: 80
 Offset: 28 (35%), Referenced to phase 2:WBTL and 6:EBT, Start of Green
 Control Type: Actuated-Coordinated
 Maximum v/c Ratio: 0.92
 Intersection Signal Delay: 23.5
 Intersection LOS: C
 Intersection Capacity Utilization 66.2%
 ICU Level of Service C
 Analysis Period (min) 15

Splits and Phases: 1: Superior Ave & 17th St

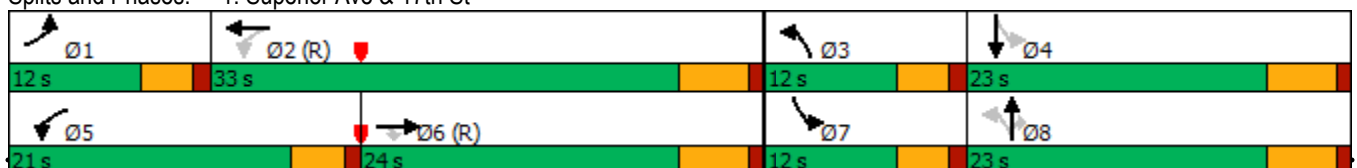

Intersection						
Int Delay, s/veh	0.9					
Movement	WBL	WBR	NBT	NBR	SBL	SBT
Lane Configurations	↔		↕↔		↕	↕↕
Traffic Vol, veh/h	22	40	752	15	26	579
Future Vol, veh/h	22	40	752	15	26	579
Conflicting Peds, #/hr	0	0	0	0	0	0
Sign Control	Stop	Stop	Free	Free	Free	Free
RT Channelized	-	None	-	None	-	None
Storage Length	0	-	-	-	65	-
Veh in Median Storage, #	0	-	0	-	-	0
Grade, %	0	-	0	-	-	0
Peak Hour Factor	84	84	84	84	84	84
Heavy Vehicles, %	2	2	2	2	2	2
Mvmt Flow	26	48	895	18	31	689

Major/Minor	Minor1	Major1	Major2		
Conflicting Flow All	1311	457	0	0	913
Stage 1	904	-	-	-	-
Stage 2	407	-	-	-	-
Critical Hdwy	6.84	6.94	-	-	4.14
Critical Hdwy Stg 1	5.84	-	-	-	-
Critical Hdwy Stg 2	5.84	-	-	-	-
Follow-up Hdwy	3.52	3.32	-	-	2.22
Pot Cap-1 Maneuver	150	551	-	-	742
Stage 1	355	-	-	-	-
Stage 2	641	-	-	-	-
Platoon blocked, %			-	-	-
Mov Cap-1 Maneuver	144	551	-	-	742
Mov Cap-2 Maneuver	264	-	-	-	-
Stage 1	355	-	-	-	-
Stage 2	614	-	-	-	-

Approach	WB	NB	SB
HCM Control Delay, s	16.1	0	0.4
HCM LOS	C		

Minor Lane/Major Mvmt	NBT	NBRWBLn1	SBL	SBT
Capacity (veh/h)	-	-	398	742
HCM Lane V/C Ratio	-	-	0.185	0.042
HCM Control Delay (s)	-	-	16.1	10.1
HCM Lane LOS	-	-	C	B
HCM 95th %tile Q(veh)	-	-	0.7	0.1

Intersection												
Int Delay, s/veh	2.5											
Movement	EBL	EBT	EBR	WBL	WBT	WBR	NBL	NBT	NBR	SBL	SBT	SBR
Lane Configurations		↶			↷			↷			↶	
Traffic Vol, veh/h	1	44	1	13	64	3	2	0	10	8	1	11
Future Vol, veh/h	1	44	1	13	64	3	2	0	10	8	1	11
Conflicting Peds, #/hr	0	0	0	0	0	0	0	0	0	0	0	0
Sign Control	Free	Free	Free	Free	Free	Free	Stop	Stop	Stop	Stop	Stop	Stop
RT Channelized	-	-	None	-	-	None	-	-	None	-	-	None
Storage Length	-	-	-	-	-	-	-	-	-	-	-	-
Veh in Median Storage, #	-	0	-	-	0	-	-	0	-	-	0	-
Grade, %	-	0	-	-	0	-	-	0	-	-	0	-
Peak Hour Factor	72	72	72	72	72	72	72	72	72	72	72	72
Heavy Vehicles, %	2	2	2	2	2	2	2	2	2	2	2	2
Mvmt Flow	1	61	1	18	89	4	3	0	14	11	1	15

Major/Minor	Major1			Major2			Minor1			Minor2		
Conflicting Flow All	93	0	0	62	0	0	199	193	62	198	191	91
Stage 1	-	-	-	-	-	-	64	64	-	127	127	-
Stage 2	-	-	-	-	-	-	135	129	-	71	64	-
Critical Hdwy	4.12	-	-	4.12	-	-	7.12	6.52	6.22	7.12	6.52	6.22
Critical Hdwy Stg 1	-	-	-	-	-	-	6.12	5.52	-	6.12	5.52	-
Critical Hdwy Stg 2	-	-	-	-	-	-	6.12	5.52	-	6.12	5.52	-
Follow-up Hdwy	2.218	-	-	2.218	-	-	3.518	4.018	3.318	3.518	4.018	3.318
Pot Cap-1 Maneuver	1501	-	-	1541	-	-	760	702	1003	761	704	967
Stage 1	-	-	-	-	-	-	947	842	-	877	791	-
Stage 2	-	-	-	-	-	-	868	789	-	939	842	-
Platoon blocked, %	-	-	-	-	-	-	-	-	-	-	-	-
Mov Cap-1 Maneuver	1501	-	-	1541	-	-	739	693	1003	743	695	967
Mov Cap-2 Maneuver	-	-	-	-	-	-	739	693	-	743	695	-
Stage 1	-	-	-	-	-	-	946	841	-	876	782	-
Stage 2	-	-	-	-	-	-	843	780	-	925	841	-

Approach	EB			WB			NB			SB		
HCM Control Delay, s	0.2			1.2			8.9			9.4		
HCM LOS							A			A		

Minor Lane/Major Mvmt	NBLn1	EBL	EBT	EBR	WBL	WBT	WBR	SBLn1
Capacity (veh/h)	947	1501	-	-	1541	-	-	848
HCM Lane V/C Ratio	0.018	0.001	-	-	0.012	-	-	0.033
HCM Control Delay (s)	8.9	7.4	-	-	7.4	0	-	9.4
HCM Lane LOS	A	A	-	-	A	A	-	A
HCM 95th %tile Q(veh)	0.1	0	-	-	0	-	-	0.1

Existing Conditions - PM Peak Hour
4: Newport Blvd & E 16th St

Lanes, Volumes, Timings
Synchro 11 Report

Lane Group	EBL	EBT	EBR	WBL	WBT	WBR	NBL	NBT	NBR	SBL	SBT	SBR
Lane Configurations												
Traffic Volume (vph)	16	32	19	85	47	53	17	1689	74	49	1718	12
Future Volume (vph)	16	32	19	85	47	53	17	1689	74	49	1718	12
Ideal Flow (vphpl)	1900	1900	1900	1900	1900	1900	1900	1900	1900	1900	1900	1900
Storage Length (ft)	0		0	0		0	95		0	85		55
Storage Lanes	0		0	0		0	1		0	1		1
Taper Length (ft)	25			25			25			25		
Satd. Flow (prot)	0	1770	0	0	1751	0	1770	5055	0	1770	5085	1583
Flt Permitted		0.872			0.817		0.950			0.950		
Satd. Flow (perm)	0	1563	0	0	1463	0	1770	5055	0	1770	5085	1583
Right Turn on Red			Yes			Yes			No			Yes
Satd. Flow (RTOR)		14			15							57
Link Speed (mph)		25			25			50				50
Link Distance (ft)		160			479			1146				979
Travel Time (s)		4.4			13.1			15.6				13.4
Peak Hour Factor	0.89	0.89	0.89	0.89	0.89	0.89	1.00	0.89	0.89	0.89	0.89	0.89
Shared Lane Traffic (%)												
Lane Group Flow (vph)	0	75	0	0	209	0	17	1981	0	55	1930	13
Turn Type	Perm	NA		Perm	NA		Prot	NA		Prot	NA	Perm
Protected Phases		4			8		5	2		1	6	
Permitted Phases	4			8								6
Total Split (s)	45.0	45.0		45.0	45.0		15.2	75.7		18.2	75.7	75.7
Total Lost Time (s)		6.0			6.0		4.2	5.7		4.2	5.7	5.7
Act Effct Green (s)		23.1			23.1		9.0	92.6		9.9	98.8	98.8
Actuated g/C Ratio		0.17			0.17		0.06	0.67		0.07	0.71	0.71
v/c Ratio		0.28			0.82		0.15	0.59		0.44	0.53	0.01
Control Delay		41.3			75.3		64.6	15.3		72.4	11.8	0.0
Queue Delay		0.0			0.0		0.0	0.0		0.0	0.0	0.0
Total Delay		41.3			75.3		64.6	15.3		72.4	11.8	0.0
LOS		D			E		E	B		E	B	A
Approach Delay		41.3			75.3			15.7			13.4	
Approach LOS		D			E			B			B	

Intersection Summary

Area Type: Other
 Cycle Length: 138.9
 Actuated Cycle Length: 138.9
 Offset: 98 (71%), Referenced to phase 2:NBT and 6:SBT, Start of Green
 Control Type: Actuated-Coordinated
 Maximum v/c Ratio: 0.82
 Intersection Signal Delay: 18.0
 Intersection LOS: B
 Intersection Capacity Utilization 67.6%
 ICU Level of Service C
 Analysis Period (min) 15

Splits and Phases: 4: Newport Blvd & E 16th St



Existing Conditions - PM Peak Hour
5: Superior Ave & W 16th St/Industrial Way

Lanes, Volumes, Timings
Synchro 11 Report

Lane Group	EBL	EBT	EBR	WBL	WBT	WBR	NBL	NBT	NBR	SBL	SBT	SBR
Lane Configurations												
Traffic Volume (vph)	80	85	66	24	76	21	44	598	57	26	477	54
Future Volume (vph)	80	85	66	24	76	21	44	598	57	26	477	54
Ideal Flow (vphpl)	1900	1900	1900	1900	1900	1900	1900	1900	1900	1900	1900	1900
Storage Length (ft)	0		0	0		0	100		110	100		0
Storage Lanes	1		0	0		0	1		1	1		0
Taper Length (ft)	25			25			25			25		
Satd. Flow (prot)	1770	1742	0	0	1800	0	1770	3539	1583	1770	3486	0
Flt Permitted	0.950				0.990		0.284			0.230		
Satd. Flow (perm)	1770	1742	0	0	1800	0	529	3539	1583	428	3486	0
Right Turn on Red			Yes			Yes			Yes			No
Satd. Flow (RTOR)		39			8				64			
Link Speed (mph)		30			30			40			35	
Link Distance (ft)		216			687			694			1138	
Travel Time (s)		4.9			15.6			11.8			22.2	
Peak Hour Factor	0.82	0.82	0.82	0.82	0.82	0.82	0.82	0.82	0.82	0.82	0.82	0.82
Shared Lane Traffic (%)												
Lane Group Flow (vph)	98	184	0	0	148	0	54	729	70	32	648	0
Turn Type	Split	NA		Split	NA		Perm	NA	Perm	Perm	NA	
Protected Phases	6	6		2	2			3			3	
Permitted Phases							3		3	3		
Total Split (s)	56.1	56.1		35.1	35.1		30.9	30.9	30.9	30.9	30.9	
Total Lost Time (s)	5.1	5.1			5.1		5.9	5.9	5.9	5.9	5.9	
Act Effct Green (s)	11.3	11.3			30.0		25.0	25.0	25.0	25.0	25.0	
Actuated g/C Ratio	0.14	0.14			0.36		0.30	0.30	0.30	0.30	0.30	
v/c Ratio	0.40	0.68			0.22		0.34	0.68	0.13	0.25	0.61	
Control Delay	37.2	39.2			19.1		30.9	29.6	8.1	29.2	28.1	
Queue Delay	0.0	0.0			0.0		0.0	0.0	0.0	0.0	0.0	
Total Delay	37.2	39.2			19.1		30.9	29.6	8.1	29.2	28.1	
LOS	D	D			B		C	C	A	C	C	
Approach Delay		38.5			19.1			27.9			28.2	
Approach LOS		D			B			C			C	

Intersection Summary

Area Type: Other
 Cycle Length: 122.1
 Actuated Cycle Length: 82.5
 Control Type: Actuated-Uncoordinated
 Maximum v/c Ratio: 0.68
 Intersection Signal Delay: 28.9
 Intersection LOS: C
 Intersection Capacity Utilization 53.3%
 ICU Level of Service A
 Analysis Period (min) 15

Splits and Phases: 5: Superior Ave & W 16th St/Industrial Way



Existing Conditions - PM Peak Hour
6: Industrial Way & Old Newport Blvd (W)

Intersection												
Int Delay, s/veh	1.5											
Movement	EBL	EBT	EBR	WBL	WBT	WBR	NBL	NBT	NBR	SBL	SBT	SBR
Lane Configurations		↕			↕			↕			↕	
Traffic Vol, veh/h	1	159	9	16	107	7	7	0	14	6	0	12
Future Vol, veh/h	1	159	9	16	107	7	7	0	14	6	0	12
Conflicting Peds, #/hr	0	0	0	0	0	0	0	0	0	0	0	0
Sign Control	Free	Free	Free	Free	Free	Free	Stop	Stop	Stop	Stop	Stop	Stop
RT Channelized	-	-	None	-	-	None	-	-	None	-	-	None
Storage Length	-	-	-	-	-	-	-	-	-	-	-	-
Veh in Median Storage, #	-	0	-	-	0	-	-	0	-	-	0	-
Grade, %	-	0	-	-	0	-	-	0	-	-	0	-
Peak Hour Factor	76	76	76	76	76	76	76	76	76	76	76	76
Heavy Vehicles, %	2	2	2	2	2	2	2	2	2	2	2	2
Mvmt Flow	1	209	12	21	141	9	9	0	18	8	0	16

Major/Minor	Major1			Major2			Minor1			Minor2		
Conflicting Flow All	150	0	0	221	0	0	413	409	215	414	411	146
Stage 1	-	-	-	-	-	-	217	217	-	188	188	-
Stage 2	-	-	-	-	-	-	196	192	-	226	223	-
Critical Hdwy	4.12	-	-	4.12	-	-	7.12	6.52	6.22	7.12	6.52	6.22
Critical Hdwy Stg 1	-	-	-	-	-	-	6.12	5.52	-	6.12	5.52	-
Critical Hdwy Stg 2	-	-	-	-	-	-	6.12	5.52	-	6.12	5.52	-
Follow-up Hdwy	2.218	-	-	2.218	-	-	3.518	4.018	3.318	3.518	4.018	3.318
Pot Cap-1 Maneuver	1431	-	-	1348	-	-	549	532	825	549	531	901
Stage 1	-	-	-	-	-	-	785	723	-	814	745	-
Stage 2	-	-	-	-	-	-	806	742	-	777	719	-
Platoon blocked, %	-	-	-	-	-	-	-	-	-	-	-	-
Mov Cap-1 Maneuver	1431	-	-	1348	-	-	532	522	825	529	521	901
Mov Cap-2 Maneuver	-	-	-	-	-	-	532	522	-	529	521	-
Stage 1	-	-	-	-	-	-	784	722	-	813	732	-
Stage 2	-	-	-	-	-	-	778	729	-	759	718	-

Approach	EB			WB			NB			SB		
HCM Control Delay, s	0			0.9			10.4			10.1		
HCM LOS							B			B		

Minor Lane/Major Mvmt	NBLn1	EBL	EBT	EBR	WBL	WBT	WBR	SBLn1
Capacity (veh/h)	697	1431	-	-	1348	-	-	730
HCM Lane V/C Ratio	0.04	0.001	-	-	0.016	-	-	0.032
HCM Control Delay (s)	10.4	7.5	0	-	7.7	0	-	10.1
HCM Lane LOS	B	A	A	-	A	A	-	B
HCM 95th %tile Q(veh)	0.1	0	-	-	0	-	-	0.1

Existing Conditions - PM Peak Hour
7: Newport Blvd & Industrial Way

Lanes, Volumes, Timings
Synchro 11 Report

Lane Group	EBL	EBT	EBR	WBL	WBT	WBR	NBL	NBT	NBR	SBL	SBT	SBR
Lane Configurations												
Traffic Volume (vph)	56	56	62	12	68	109	28	1610	8	62	1717	43
Future Volume (vph)	56	56	62	12	68	109	28	1610	8	62	1717	43
Ideal Flow (vphpl)	1900	1900	1900	1900	1900	1900	1900	1900	1900	1900	1900	1900
Storage Length (ft)	0		0	0		0	90		0	95		0
Storage Lanes	0		1	1		1	1		0	1		0
Taper Length (ft)	25			25			25			25		
Satd. Flow (prot)	0	1818	1583	1770	1863	1583	1770	5080	0	1770	5065	0
Flt Permitted		0.747		0.468			0.950			0.950		
Satd. Flow (perm)	0	1391	1583	872	1863	1583	1770	5080	0	1770	5065	0
Right Turn on Red			Yes			Yes			Yes			Yes
Satd. Flow (RTOR)			90			125		1				4
Link Speed (mph)		30			30			50				50
Link Distance (ft)		175			191			846				1146
Travel Time (s)		4.0			4.3			11.5				15.6
Peak Hour Factor	0.87	0.87	0.87	0.87	0.87	0.87	0.87	0.87	0.87	0.87	0.87	0.87
Shared Lane Traffic (%)												
Lane Group Flow (vph)	0	128	71	14	78	125	32	1860	0	71	2023	0
Turn Type	Perm	NA	Perm	Perm	NA	Perm	Prot	NA		Prot	NA	
Protected Phases		4			8		5	2		1	6	
Permitted Phases	4		4	8		8						
Total Split (s)	40.6	40.6	40.6	40.6	40.6	40.6	14.2	76.4		26.2	76.4	
Total Lost Time (s)		4.6	4.6	4.6	4.6	4.6	4.2	6.4		4.2	6.4	
Act Effct Green (s)		16.6	16.6	16.6	16.6	16.6	9.1	103.5		10.6	107.6	
Actuated g/C Ratio		0.12	0.12	0.12	0.12	0.12	0.06	0.72		0.07	0.75	
v/c Ratio		0.80	0.27	0.14	0.36	0.43	0.29	0.51		0.54	0.53	
Control Delay		93.3	8.0	57.2	61.6	13.1	70.8	10.6		79.0	9.3	
Queue Delay		0.0	0.0	0.0	0.0	0.0	0.0	0.0		0.0	0.0	
Total Delay		93.3	8.0	57.2	61.6	13.1	70.8	10.6		79.0	9.3	
LOS		F	A	E	E	B	E	B		E	A	
Approach Delay		62.9			33.4			11.6			11.6	
Approach LOS		E			C			B			B	

Intersection Summary

Area Type: Other
 Cycle Length: 143.2
 Actuated Cycle Length: 143.2
 Offset: 88 (61%), Referenced to phase 2:NBT and 6:SBT, Start of Green
 Control Type: Actuated-Coordinated
 Maximum v/c Ratio: 0.80
 Intersection Signal Delay: 15.0
 Intersection LOS: B
 Intersection Capacity Utilization 67.0%
 ICU Level of Service C
 Analysis Period (min) 15

Splits and Phases: 7: Newport Blvd & Industrial Way

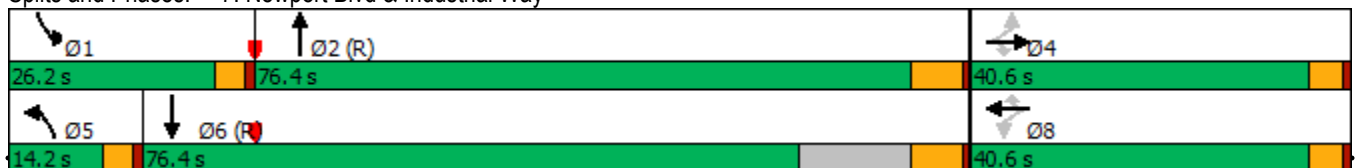

EXISTING CONDITIONS MID-DAY (SATURDAY)

Existing Conditions - Mid-Day (Saturday)

Lanes, Volumes, Timings

1: Superior Ave & 17th St

Synchro 11 Report

Lane Group	EBL	EBT	EBR	WBL	WBT	WBR	NBL	NBT	NBR	SBL	SBT	SBR
Lane Configurations												
Traffic Volume (vph)	27	514	61	220	426	84	77	118	440	119	193	120
Future Volume (vph)	27	514	61	220	426	84	77	118	440	119	193	120
Ideal Flow (vphpl)	1900	1900	1900	1900	1900	1900	1900	1900	1900	1900	1900	1900
Storage Length (ft)	100		250	0		0	80		0	90		0
Storage Lanes	1		1	1		0	1		1	1		0
Taper Length (ft)	25			25			25			25		
Satd. Flow (prot)	1770	3539	1583	1770	3451	0	1770	1612	1504	1770	3337	0
Flt Permitted	0.950			0.324			0.506			0.284		
Satd. Flow (perm)	1770	3539	1583	604	3451	0	943	1612	1504	529	3337	0
Right Turn on Red			Yes			Yes			Yes			Yes
Satd. Flow (RTOR)			214		33			88	289		129	
Link Speed (mph)		35			30			35			35	
Link Distance (ft)		556			357			606			247	
Travel Time (s)		10.8			8.1			11.8			4.8	
Peak Hour Factor	0.93	0.93	0.93	0.93	0.93	0.93	0.93	0.93	0.93	0.93	0.93	0.93
Shared Lane Traffic (%)									39%			
Lane Group Flow (vph)	29	553	66	237	548	0	83	311	289	128	337	0
Turn Type	Prot	NA	Perm	pm+pt	NA		pm+pt	NA	Perm	pm+pt	NA	
Protected Phases	1	6		5	2		3	8		7	4	
Permitted Phases			6	2			8		8	4		
Total Split (s)	12.0	22.0	22.0	20.0	30.0		12.0	21.0	21.0	12.0	21.0	
Total Lost Time (s)	4.2	5.1	5.1	4.2	5.1		4.2	5.1	5.1	4.2	5.1	
Act Effct Green (s)	5.7	27.5	27.5	42.6	37.4		20.2	13.6	13.6	21.0	14.1	
Actuated g/C Ratio	0.08	0.37	0.37	0.57	0.50		0.27	0.18	0.18	0.28	0.19	
v/c Ratio	0.22	0.43	0.09	0.47	0.32		0.25	0.85	0.57	0.48	0.46	
Control Delay	36.1	21.9	0.3	13.2	13.8		17.7	43.3	8.3	23.1	18.0	
Queue Delay	0.0	0.0	0.0	0.0	0.0		0.0	0.0	0.0	0.0	0.0	
Total Delay	36.1	21.9	0.3	13.2	13.8		17.7	43.3	8.3	23.1	18.0	
LOS	D	C	A	B	B		B	D	A	C	B	
Approach Delay		20.3			13.6			25.4			19.4	
Approach LOS		C			B			C			B	

Intersection Summary

Area Type: Other
 Cycle Length: 75
 Actuated Cycle Length: 75
 Offset: 9.6 (13%), Referenced to phase 2:WBTL and 6:EBT, Start of Green
 Control Type: Actuated-Coordinated
 Maximum v/c Ratio: 0.85
 Intersection Signal Delay: 19.5 Intersection LOS: B
 Intersection Capacity Utilization 63.7% ICU Level of Service B
 Analysis Period (min) 15

Splits and Phases: 1: Superior Ave & 17th St

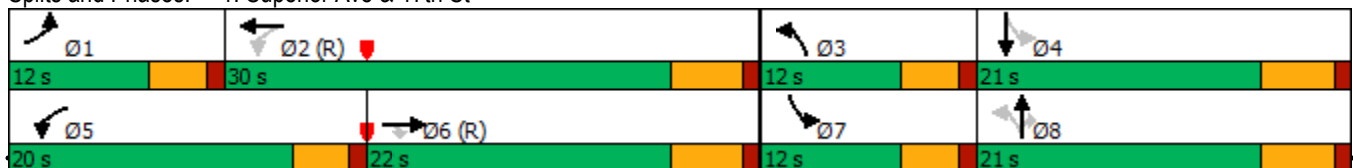

Intersection						
Int Delay, s/veh	1.1					
Movement	WBL	WBR	NBT	NBR	SBL	SBT
Lane Configurations	↔		↕↔		↔	↕↕
Traffic Vol, veh/h	31	43	594	18	31	460
Future Vol, veh/h	31	43	594	18	31	460
Conflicting Peds, #/hr	0	0	0	0	0	0
Sign Control	Stop	Stop	Free	Free	Free	Free
RT Channelized	-	None	-	None	-	None
Storage Length	0	-	-	-	65	-
Veh in Median Storage, #	0	-	0	-	-	0
Grade, %	0	-	0	-	-	0
Peak Hour Factor	92	100	92	92	92	92
Heavy Vehicles, %	2	2	2	2	2	2
Mvmt Flow	34	43	646	20	34	500

Major/Minor	Minor1	Major1	Major2		
Conflicting Flow All	974	333	0	0	666
Stage 1	656	-	-	-	-
Stage 2	318	-	-	-	-
Critical Hdwy	6.84	6.94	-	-	4.14
Critical Hdwy Stg 1	5.84	-	-	-	-
Critical Hdwy Stg 2	5.84	-	-	-	-
Follow-up Hdwy	3.52	3.32	-	-	2.22
Pot Cap-1 Maneuver	249	663	-	-	919
Stage 1	478	-	-	-	-
Stage 2	710	-	-	-	-
Platoon blocked, %			-	-	-
Mov Cap-1 Maneuver	240	663	-	-	919
Mov Cap-2 Maneuver	361	-	-	-	-
Stage 1	478	-	-	-	-
Stage 2	684	-	-	-	-

Approach	WB	NB	SB
HCM Control Delay, s	13.8	0	0.6
HCM LOS	B		

Minor Lane/Major Mvmt	NBT	NBRWBLn1	SBL	SBT
Capacity (veh/h)	-	-	485	919
HCM Lane V/C Ratio	-	-	0.158	0.037
HCM Control Delay (s)	-	-	13.8	9.1
HCM Lane LOS	-	-	B	A
HCM 95th %tile Q(veh)	-	-	0.6	0.1

Existing Conditions - Mid-Day (Saturday)
 3: Old Newport Blvd (W) & E 16th St

Intersection												
Int Delay, s/veh	2.4											
Movement	EBL	EBT	EBR	WBL	WBT	WBR	NBL	NBT	NBR	SBL	SBT	SBR
Lane Configurations		↻			↻			↻			↻	
Traffic Vol, veh/h	3	42	6	16	73	8	2	0	19	9	0	3
Future Vol, veh/h	3	42	6	16	73	8	2	0	19	9	0	3
Conflicting Peds, #/hr	0	0	0	0	0	0	0	0	0	0	0	0
Sign Control	Free	Free	Free	Free	Free	Free	Stop	Stop	Stop	Stop	Stop	Stop
RT Channelized	-	-	None	-	-	None	-	-	None	-	-	None
Storage Length	-	-	-	-	-	-	-	-	-	-	-	-
Veh in Median Storage, #	-	0	-	-	0	-	-	0	-	-	0	-
Grade, %	-	0	-	-	0	-	-	0	-	-	0	-
Peak Hour Factor	94	94	94	94	94	94	94	94	94	94	94	94
Heavy Vehicles, %	2	2	2	2	2	2	2	2	2	2	2	2
Mvmt Flow	3	45	6	17	78	9	2	0	20	10	0	3

Major/Minor	Major1			Major2			Minor1			Minor2		
Conflicting Flow All	87	0	0	51	0	0	172	175	48	181	174	83
Stage 1	-	-	-	-	-	-	54	54	-	117	117	-
Stage 2	-	-	-	-	-	-	118	121	-	64	57	-
Critical Hdwy	4.12	-	-	4.12	-	-	7.12	6.52	6.22	7.12	6.52	6.22
Critical Hdwy Stg 1	-	-	-	-	-	-	6.12	5.52	-	6.12	5.52	-
Critical Hdwy Stg 2	-	-	-	-	-	-	6.12	5.52	-	6.12	5.52	-
Follow-up Hdwy	2.218	-	-	2.218	-	-	3.518	4.018	3.318	3.518	4.018	3.318
Pot Cap-1 Maneuver	1509	-	-	1555	-	-	791	718	1021	781	719	976
Stage 1	-	-	-	-	-	-	958	850	-	888	799	-
Stage 2	-	-	-	-	-	-	887	796	-	947	847	-
Platoon blocked, %	-	-	-	-	-	-	-	-	-	-	-	-
Mov Cap-1 Maneuver	1509	-	-	1555	-	-	781	709	1021	758	710	976
Mov Cap-2 Maneuver	-	-	-	-	-	-	781	709	-	758	710	-
Stage 1	-	-	-	-	-	-	956	848	-	886	790	-
Stage 2	-	-	-	-	-	-	874	787	-	926	845	-

Approach	EB			WB			NB			SB		
HCM Control Delay, s	0.4			1.2			8.7			9.6		
HCM LOS							A			A		

Minor Lane/Major Mvmt	NBLn1	EBL	EBT	EBR	WBL	WBT	WBR	SBLn1
Capacity (veh/h)	992	1509	-	-	1555	-	-	803
HCM Lane V/C Ratio	0.023	0.002	-	-	0.011	-	-	0.016
HCM Control Delay (s)	8.7	7.4	-	-	7.3	0	-	9.6
HCM Lane LOS	A	A	-	-	A	A	-	A
HCM 95th %tile Q(veh)	0.1	0	-	-	0	-	-	0

Existing Conditions - Mid-Day (Saturday)

Lanes, Volumes, Timings

4: Newport Blvd & E 16th St

Synchro 11 Report



Lane Group	EBL	EBT	EBR	WBL	WBT	WBR	NBL	NBT	NBR	SBL	SBT	SBR
Lane Configurations		↕			↕		↕	↑↑↑		↕	↑↑↑	↕
Traffic Volume (vph)	21	28	16	80	47	81	16	1865	80	51	1969	14
Future Volume (vph)	21	28	16	80	47	81	16	1865	80	51	1969	14
Ideal Flow (vphpl)	1900	1900	1900	1900	1900	1900	1900	1900	1900	1900	1900	1900
Storage Length (ft)	0		0	0		0	95		0	85		55
Storage Lanes	0		0	0		0	1		0	1		1
Taper Length (ft)	25			25			25			25		
Satd. Flow (prot)	0	1772	0	0	1731	0	1770	5055	0	1770	5085	1583
Flt Permitted		0.790			0.851		0.950			0.950		
Satd. Flow (perm)	0	1423	0	0	1501	0	1770	5055	0	1770	5085	1583
Right Turn on Red			Yes			Yes			No			Yes
Satd. Flow (RTOR)		11			23							56
Link Speed (mph)		25			25			50			50	
Link Distance (ft)		160			479			1146			979	
Travel Time (s)		4.4			13.1			15.6			13.4	
Peak Hour Factor	0.92	0.92	0.92	0.92	0.92	0.92	0.92	0.92	0.92	0.92	0.92	0.92
Shared Lane Traffic (%)												
Lane Group Flow (vph)	0	70	0	0	226	0	17	2114	0	55	2140	15
Turn Type	Perm	NA		Perm	NA		Prot	NA		Prot	NA	Perm
Protected Phases		4			8		5	2		1	6	
Permitted Phases	4			8								6
Total Split (s)	45.0	45.0		45.0	45.0		18.2	75.7		19.2	75.7	75.7
Total Lost Time (s)		6.0			6.0		4.2	5.7		4.2	5.7	5.7
Act Effct Green (s)		23.8			23.8		9.0	92.8		10.0	99.1	99.1
Actuated g/C Ratio		0.17			0.17		0.06	0.66		0.07	0.71	0.71
v/c Ratio		0.28			0.82		0.15	0.63		0.44	0.59	0.01
Control Delay		42.9			72.8		65.2	16.6		73.1	13.1	0.0
Queue Delay		0.0			0.0		0.0	0.0		0.0	0.0	0.0
Total Delay		42.9			72.8		65.2	16.6		73.1	13.1	0.0
LOS		D			E		E	B		E	B	A
Approach Delay		42.9			72.8			16.9			14.5	
Approach LOS		D			E			B			B	

Intersection Summary

Area Type: Other
 Cycle Length: 139.9
 Actuated Cycle Length: 139.9
 Offset: 103 (74%), Referenced to phase 2:NBT and 6:SBT, Start of Green
 Control Type: Actuated-Coordinated
 Maximum v/c Ratio: 0.82
 Intersection Signal Delay: 18.9
 Intersection LOS: B
 Intersection Capacity Utilization 68.9%
 ICU Level of Service C
 Analysis Period (min) 15

Splits and Phases: 4: Newport Blvd & E 16th St



Existing Conditions - Mid-Day (Saturday)
5: Superior Ave & W 16th St/Industrial Way

Lanes, Volumes, Timings
Synchro 11 Report

Lane Group	EBL	EBT	EBR	WBL	WBT	WBR	NBL	NBT	NBR	SBL	SBT	SBR
Lane Configurations												
Traffic Volume (vph)	71	88	74	20	54	33	23	477	29	25	369	62
Future Volume (vph)	71	88	74	20	54	33	23	477	29	25	369	62
Ideal Flow (vphpl)	1900	1900	1900	1900	1900	1900	1900	1900	1900	1900	1900	1900
Storage Length (ft)	0		0	0		0	100		110	100		0
Storage Lanes	1		0	0		0	1		1	1		0
Taper Length (ft)	25			25			25			25		
Satd. Flow (prot)	1770	1736	0	0	1768	0	1770	3539	1583	1770	3461	0
Flt Permitted	0.950				0.991		0.437			0.396		
Satd. Flow (perm)	1770	1736	0	0	1768	0	814	3539	1583	738	3461	0
Right Turn on Red			Yes			Yes			Yes			No
Satd. Flow (RTOR)		42			18				64			
Link Speed (mph)		30			30			40			35	
Link Distance (ft)		216			687			694			1138	
Travel Time (s)		4.9			15.6			11.8			22.2	
Peak Hour Factor	0.95	0.95	0.95	0.95	0.95	0.95	0.95	0.95	0.95	0.95	0.95	0.95
Shared Lane Traffic (%)												
Lane Group Flow (vph)	75	171	0	0	113	0	24	502	31	26	453	0
Turn Type	Split	NA		Split	NA		Perm	NA	Perm	Perm	NA	
Protected Phases	6	6		2	2			3			3	
Permitted Phases							3		3	3		
Total Split (s)	56.1	56.1		35.1	35.1		30.9	30.9	30.9	30.9	30.9	
Total Lost Time (s)	5.1	5.1			5.1		5.9	5.9	5.9	5.9	5.9	
Act Effct Green (s)	10.5	10.5			30.0		25.0	25.0	25.0	25.0	25.0	
Actuated g/C Ratio	0.13	0.13			0.37		0.31	0.31	0.31	0.31	0.31	
v/c Ratio	0.33	0.66			0.17		0.10	0.46	0.06	0.12	0.43	
Control Delay	36.0	37.8			16.3		23.0	25.1	1.9	23.5	24.7	
Queue Delay	0.0	0.0			0.0		0.0	0.0	0.0	0.0	0.0	
Total Delay	36.0	37.8			16.3		23.0	25.1	1.9	23.5	24.7	
LOS	D	D			B		C	C	A	C	C	
Approach Delay		37.2			16.3			23.8			24.6	
Approach LOS		D			B			C			C	

Intersection Summary

Area Type: Other
 Cycle Length: 122.1
 Actuated Cycle Length: 81.7
 Control Type: Actuated-Uncoordinated
 Maximum v/c Ratio: 0.66
 Intersection Signal Delay: 25.8
 Intersection LOS: C
 Intersection Capacity Utilization 49.3%
 ICU Level of Service A
 Analysis Period (min) 15

Splits and Phases: 5: Superior Ave & W 16th St/Industrial Way



Intersection												
Int Delay, s/veh	2.2											
Movement	EBL	EBT	EBR	WBL	WBT	WBR	NBL	NBT	NBR	SBL	SBT	SBR
Lane Configurations		↕			↕			↕			↕	
Traffic Vol, veh/h	2	128	16	24	80	5	13	0	21	3	0	12
Future Vol, veh/h	2	128	16	24	80	5	13	0	21	3	0	12
Conflicting Peds, #/hr	0	0	0	0	0	0	0	0	0	0	0	0
Sign Control	Free	Free	Free	Free	Free	Free	Stop	Stop	Stop	Stop	Stop	Stop
RT Channelized	-	-	None	-	-	None	-	-	None	-	-	None
Storage Length	-	-	-	-	-	-	-	-	-	-	-	-
Veh in Median Storage, #	-	0	-	-	0	-	-	0	-	-	0	-
Grade, %	-	0	-	-	0	-	-	0	-	-	0	-
Peak Hour Factor	89	89	89	89	89	89	89	89	89	89	89	89
Heavy Vehicles, %	2	2	2	2	2	2	2	2	2	2	2	2
Mvmt Flow	2	144	18	27	90	6	15	0	24	3	0	13

Major/Minor	Major1			Major2			Minor1			Minor2		
Conflicting Flow All	96	0	0	162	0	0	311	307	153	316	313	93
Stage 1	-	-	-	-	-	-	157	157	-	147	147	-
Stage 2	-	-	-	-	-	-	154	150	-	169	166	-
Critical Hdwy	4.12	-	-	4.12	-	-	7.12	6.52	6.22	7.12	6.52	6.22
Critical Hdwy Stg 1	-	-	-	-	-	-	6.12	5.52	-	6.12	5.52	-
Critical Hdwy Stg 2	-	-	-	-	-	-	6.12	5.52	-	6.12	5.52	-
Follow-up Hdwy	2.218	-	-	2.218	-	-	3.518	4.018	3.318	3.518	4.018	3.318
Pot Cap-1 Maneuver	1498	-	-	1417	-	-	642	607	893	637	602	964
Stage 1	-	-	-	-	-	-	845	768	-	856	775	-
Stage 2	-	-	-	-	-	-	848	773	-	833	761	-
Platoon blocked, %	-	-	-	-	-	-	-	-	-	-	-	-
Mov Cap-1 Maneuver	1498	-	-	1417	-	-	623	594	893	610	589	964
Mov Cap-2 Maneuver	-	-	-	-	-	-	623	594	-	610	589	-
Stage 1	-	-	-	-	-	-	844	767	-	855	760	-
Stage 2	-	-	-	-	-	-	819	758	-	810	760	-

Approach	EB			WB			NB			SB		
HCM Control Delay, s	0.1			1.7			9.9			9.3		
HCM LOS							A			A		

Minor Lane/Major Mvmt	NBLn1	EBL	EBT	EBR	WBL	WBT	WBR	SBLn1
Capacity (veh/h)	766	1498	-	-	1417	-	-	864
HCM Lane V/C Ratio	0.05	0.002	-	-	0.019	-	-	0.02
HCM Control Delay (s)	9.9	7.4	0	-	7.6	0	-	9.3
HCM Lane LOS	A	A	A	-	A	A	-	A
HCM 95th %tile Q(veh)	0.2	0	-	-	0.1	-	-	0.1

Existing Conditions - Mid-Day (Saturday)
7: Newport Blvd & Industrial Way

Lanes, Volumes, Timings
Synchro 11 Report

Lane Group	EBL	EBT	EBR	WBL	WBT	WBR	NBL	NBT	NBR	SBL	SBT	SBR
Lane Configurations												
Traffic Volume (vph)	34	52	66	11	41	64	26	1870	16	43	1973	37
Future Volume (vph)	34	52	66	11	41	64	26	1870	16	43	1973	37
Ideal Flow (vphpl)	1900	1900	1900	1900	1900	1900	1900	1900	1900	1900	1900	1900
Storage Length (ft)	0		0	0		0	90		0	95		0
Storage Lanes	0		1	1		1	1		0	1		0
Taper Length (ft)	25			25			25			25		
Satd. Flow (prot)	0	1827	1583	1770	1863	1583	1770	5080	0	1770	5070	0
Flt Permitted		0.852		0.594			0.950			0.950		
Satd. Flow (perm)	0	1587	1583	1106	1863	1583	1770	5080	0	1770	5070	0
Right Turn on Red			Yes			Yes			Yes			Yes
Satd. Flow (RTOR)			94			94		1				3
Link Speed (mph)		30			30			50				50
Link Distance (ft)		175			191			846				1146
Travel Time (s)		4.0			4.3			11.5				15.6
Peak Hour Factor	0.96	0.96	0.96	0.96	0.96	0.96	0.96	0.96	0.96	0.96	0.96	0.96
Shared Lane Traffic (%)												
Lane Group Flow (vph)	0	89	69	11	43	67	27	1965	0	45	2094	0
Turn Type	Perm	NA	Perm	Perm	NA	Perm	Prot	NA		Prot	NA	
Protected Phases		4			8		5	2		1	6	
Permitted Phases	4		4	8		8						
Total Split (s)	40.6	40.6	40.6	40.6	40.6	40.6	15.2	76.4		20.2	76.4	
Total Lost Time (s)		4.6	4.6	4.6	4.6	4.6	4.2	6.4		4.2	6.4	
Act Effct Green (s)		12.5	12.5	12.5	12.5	12.5	9.0	102.7		9.4	105.7	
Actuated g/C Ratio		0.09	0.09	0.09	0.09	0.09	0.07	0.75		0.07	0.77	
v/c Ratio		0.62	0.30	0.11	0.25	0.29	0.23	0.52		0.37	0.54	
Control Delay		77.8	8.0	57.8	60.6	7.5	66.0	8.4		70.1	7.7	
Queue Delay		0.0	0.0	0.0	0.0	0.0	0.0	0.0		0.0	0.0	
Total Delay		77.8	8.0	57.8	60.6	7.5	66.0	8.4		70.1	7.7	
LOS		E	A	E	E	A	E	A		E	A	
Approach Delay		47.3			30.9			9.2			9.0	
Approach LOS		D			C			A			A	

Intersection Summary

Area Type: Other
 Cycle Length: 137.2
 Actuated Cycle Length: 137.2
 Offset: 102 (74%), Referenced to phase 2:NBT and 6:SBT, Start of Green
 Control Type: Actuated-Coordinated
 Maximum v/c Ratio: 0.62
 Intersection Signal Delay: 11.1 Intersection LOS: B
 Intersection Capacity Utilization 68.6% ICU Level of Service C
 Analysis Period (min) 15

Splits and Phases: 7: Newport Blvd & Industrial Way

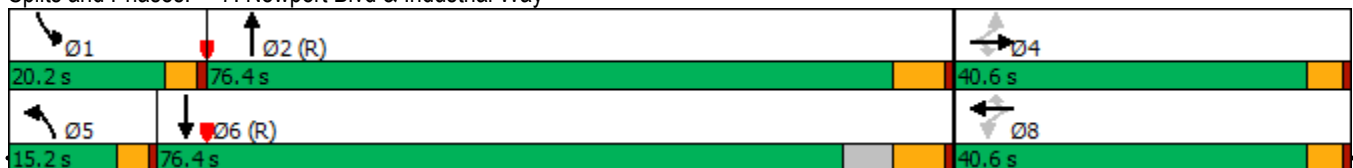

**CUMULATIVE CONDITIONS
WITHOUT PROJECT
MID-DAY**

Cumulative Conditions without Project - Mid-Day

Lanes, Volumes, Timings

1: Superior Ave & 17th St

Synchro 11 Report

Lane Group	EBL	EBT	EBR	WBL	WBT	WBR	NBL	NBT	NBR	SBL	SBT	SBR
Lane Configurations												
Traffic Volume (vph)	54	591	74	218	462	73	110	158	528	102	319	99
Future Volume (vph)	54	591	74	218	462	73	110	158	528	102	319	99
Ideal Flow (vphpl)	1900	1900	1900	1900	1900	1900	1900	1900	1900	1900	1900	1900
Storage Length (ft)	100		250	0		0	80		0	90		0
Storage Lanes	1		1	1		0	1		1	1		0
Taper Length (ft)	25			25			25			25		
Satd. Flow (prot)	1770	3539	1583	1770	3465	0	1770	1623	1504	1770	3412	0
Flt Permitted	0.950			0.288			0.405			0.256		
Satd. Flow (perm)	1770	3539	1583	536	3465	0	754	1623	1504	477	3412	0
Right Turn on Red			Yes			Yes			Yes			Yes
Satd. Flow (RTOR)			214		25			75	336		50	
Link Speed (mph)		35			30			35			35	
Link Distance (ft)		556			357			606			247	
Travel Time (s)		10.8			8.1			11.8			4.8	
Peak Hour Factor	0.99	0.99	0.99	0.99	0.99	0.99	0.99	0.99	0.99	0.99	0.99	0.99
Shared Lane Traffic (%)									37%			
Lane Group Flow (vph)	55	597	75	220	541	0	111	357	336	103	422	0
Turn Type	Prot	NA	Perm	pm+pt	NA		pm+pt	NA	Perm	pm+pt	NA	
Protected Phases	1	6		5	2		3	8		7	4	
Permitted Phases			6	2			8		8	4		
Total Split (s)	12.0	22.0	22.0	20.0	30.0		12.0	21.0	21.0	12.0	21.0	
Total Lost Time (s)	4.2	5.1	5.1	4.2	5.1		4.2	5.1	5.1	4.2	5.1	
Act Effct Green (s)	6.3	26.3	26.3	40.9	33.4		22.0	15.4	15.4	22.3	15.5	
Actuated g/C Ratio	0.08	0.35	0.35	0.55	0.45		0.29	0.21	0.21	0.30	0.21	
v/c Ratio	0.37	0.48	0.11	0.49	0.35		0.36	0.91	0.58	0.40	0.57	
Control Delay	39.3	22.8	0.3	14.0	16.3		19.3	52.8	7.9	20.4	26.5	
Queue Delay	0.0	0.0	0.0	0.0	0.0		0.0	0.0	0.0	0.0	0.0	
Total Delay	39.3	22.8	0.3	14.0	16.3		19.3	52.8	7.9	20.4	26.5	
LOS	D	C	A	B	B		B	D	A	C	C	
Approach Delay		21.7			15.6			29.4			25.3	
Approach LOS		C			B			C			C	

Intersection Summary

Area Type: Other
 Cycle Length: 75
 Actuated Cycle Length: 75
 Offset: 28 (37%), Referenced to phase 2:WBTL and 6:EBT, Start of Green
 Control Type: Actuated-Coordinated
 Maximum v/c Ratio: 0.91
 Intersection Signal Delay: 23.0 Intersection LOS: C
 Intersection Capacity Utilization 68.7% ICU Level of Service C
 Analysis Period (min) 15

Splits and Phases: 1: Superior Ave & 17th St

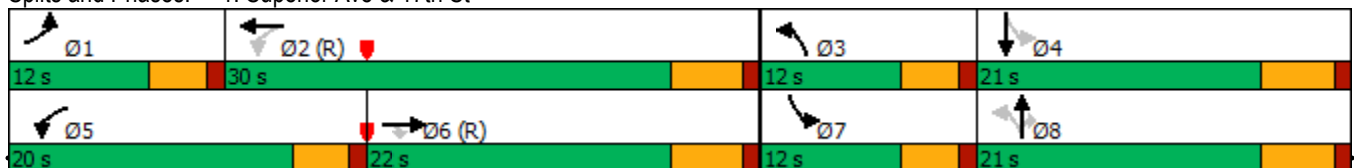

Intersection						
Int Delay, s/veh	1.1					
Movement	WBL	WBR	NBT	NBR	SBL	SBT
Lane Configurations	↘↗		↑↑		↘	↑↑
Traffic Vol, veh/h	34	47	728	18	53	649
Future Vol, veh/h	34	47	728	18	53	649
Conflicting Peds, #/hr	0	0	0	0	0	0
Sign Control	Stop	Stop	Free	Free	Free	Free
RT Channelized	-	None	-	None	-	None
Storage Length	0	-	-	-	65	-
Veh in Median Storage, #	0	-	0	-	-	0
Grade, %	0	-	0	-	-	0
Peak Hour Factor	97	97	97	97	97	97
Heavy Vehicles, %	2	2	2	2	2	2
Mvmt Flow	35	48	751	19	55	669

Major/Minor	Minor1	Major1	Major2		
Conflicting Flow All	1206	385	0	0	770
Stage 1	761	-	-	-	-
Stage 2	445	-	-	-	-
Critical Hdwy	6.84	6.94	-	-	4.14
Critical Hdwy Stg 1	5.84	-	-	-	-
Critical Hdwy Stg 2	5.84	-	-	-	-
Follow-up Hdwy	3.52	3.32	-	-	2.22
Pot Cap-1 Maneuver	176	613	-	-	840
Stage 1	422	-	-	-	-
Stage 2	613	-	-	-	-
Platoon blocked, %			-	-	-
Mov Cap-1 Maneuver	165	613	-	-	840
Mov Cap-2 Maneuver	295	-	-	-	-
Stage 1	422	-	-	-	-
Stage 2	573	-	-	-	-

Approach	WB	NB	SB
HCM Control Delay, s	15.6	0	0.7
HCM LOS	C		

Minor Lane/Major Mvmt	NBT	NBRWBLn1	SBL	SBT
Capacity (veh/h)	-	-	422	840
HCM Lane V/C Ratio	-	-	0.198	0.065
HCM Control Delay (s)	-	-	15.6	9.6
HCM Lane LOS	-	-	C	A
HCM 95th %tile Q(veh)	-	-	0.7	0.2

Cumulative Conditions Without Project - Mid-Day
 3: Old Newport Blvd (W) & E 16th St

Intersection												
Int Delay, s/veh	2.4											
Movement	EBL	EBT	EBR	WBL	WBT	WBR	NBL	NBT	NBR	SBL	SBT	SBR
Lane Configurations		↻			↻			↻			↻	
Traffic Vol, veh/h	3	56	9	21	67	7	4	0	15	9	3	0
Future Vol, veh/h	3	56	9	21	67	7	4	0	15	9	3	0
Conflicting Peds, #/hr	0	0	0	0	0	0	0	0	0	0	0	0
Sign Control	Free	Free	Free	Free	Free	Free	Stop	Stop	Stop	Stop	Stop	Stop
RT Channelized	-	-	None	-	-	None	-	-	None	-	-	None
Storage Length	-	-	-	-	-	-	-	-	-	-	-	-
Veh in Median Storage, #	-	0	-	-	0	-	-	0	-	-	0	-
Grade, %	-	0	-	-	0	-	-	0	-	-	0	-
Peak Hour Factor	91	91	91	91	91	91	91	91	91	91	91	91
Heavy Vehicles, %	2	2	2	2	2	2	2	2	2	2	2	2
Mvmt Flow	3	62	10	23	74	8	4	0	16	10	3	0

Major/Minor	Major1			Major2			Minor1			Minor2		
Conflicting Flow All	82	0	0	72	0	0	199	201	67	205	202	78
Stage 1	-	-	-	-	-	-	73	73	-	124	124	-
Stage 2	-	-	-	-	-	-	126	128	-	81	78	-
Critical Hdwy	4.12	-	-	4.12	-	-	7.12	6.52	6.22	7.12	6.52	6.22
Critical Hdwy Stg 1	-	-	-	-	-	-	6.12	5.52	-	6.12	5.52	-
Critical Hdwy Stg 2	-	-	-	-	-	-	6.12	5.52	-	6.12	5.52	-
Follow-up Hdwy	2.218	-	-	2.218	-	-	3.518	4.018	3.318	3.518	4.018	3.318
Pot Cap-1 Maneuver	1515	-	-	1528	-	-	760	695	997	753	694	983
Stage 1	-	-	-	-	-	-	937	834	-	880	793	-
Stage 2	-	-	-	-	-	-	878	790	-	927	830	-
Platoon blocked, %	-	-	-	-	-	-	-	-	-	-	-	-
Mov Cap-1 Maneuver	1515	-	-	1528	-	-	747	682	997	730	682	983
Mov Cap-2 Maneuver	-	-	-	-	-	-	747	682	-	730	682	-
Stage 1	-	-	-	-	-	-	935	832	-	878	780	-
Stage 2	-	-	-	-	-	-	860	777	-	910	828	-

Approach	EB			WB			NB			SB		
HCM Control Delay, s	0.3			1.6			9			10.1		
HCM LOS							A			B		

Minor Lane/Major Mvmt	NBLn1	EBL	EBT	EBR	WBL	WBT	WBR	SBLn1
Capacity (veh/h)	931	1515	-	-	1528	-	-	717
HCM Lane V/C Ratio	0.022	0.002	-	-	0.015	-	-	0.018
HCM Control Delay (s)	9	7.4	-	-	7.4	0	-	10.1
HCM Lane LOS	A	A	-	-	A	A	-	B
HCM 95th %tile Q(veh)	0.1	0	-	-	0	-	-	0.1

Cumulative Conditions without Project - Mid-Day
4: Newport Blvd & E 16th St

Lanes, Volumes, Timings
Synchro 11 Report

Lane Group	EBL	EBT	EBR	WBL	WBT	WBR	NBL	NBT	NBR	SBL	SBT	SBR
Lane Configurations												
Traffic Volume (vph)	31	23	12	68	37	77	31	1747	87	81	1734	28
Future Volume (vph)	31	23	12	68	37	77	31	1747	87	81	1734	28
Ideal Flow (vphpl)	1900	1900	1900	1900	1900	1900	1900	1900	1900	1900	1900	1900
Storage Length (ft)	0		0	0		0	95		0	85		55
Storage Lanes	0		0	0		0	1		0	1		1
Taper Length (ft)	25			25			25			25		
Satd. Flow (prot)	0	1776	0	0	1725	0	1770	5050	0	1770	5085	1583
Flt Permitted		0.678			0.858		0.950			0.950		
Satd. Flow (perm)	0	1233	0	0	1507	0	1770	5050	0	1770	5085	1583
Right Turn on Red			Yes			Yes			No			Yes
Satd. Flow (RTOR)		8			26							57
Link Speed (mph)		25			25			50				50
Link Distance (ft)		160			479			1146				979
Travel Time (s)		4.4			13.1			15.6				13.4
Peak Hour Factor	0.97	0.97	0.97	0.97	0.97	0.97	0.97	0.97	0.97	0.97	0.97	0.97
Shared Lane Traffic (%)												
Lane Group Flow (vph)	0	68	0	0	187	0	32	1891	0	84	1788	29
Turn Type	Perm	NA		Perm	NA		Prot	NA		Prot	NA	Perm
Protected Phases		4			8		5	2		1	6	
Permitted Phases	4			8								6
Total Split (s)	45.0	45.0		45.0	45.0		15.2	75.7		18.2	75.7	75.7
Total Lost Time (s)		6.0			6.0		4.2	5.7		4.2	5.7	5.7
Act Effct Green (s)		19.9			19.9		9.2	91.6		11.5	99.3	99.3
Actuated g/C Ratio		0.14			0.14		0.07	0.66		0.08	0.71	0.71
v/c Ratio		0.37			0.79		0.28	0.57		0.58	0.49	0.03
Control Delay		51.1			71.1		68.0	14.8		76.4	10.9	0.5
Queue Delay		0.0			0.0		0.0	0.0		0.0	0.0	0.0
Total Delay		51.1			71.1		68.0	14.8		76.4	10.9	0.5
LOS		D			E		E	B		E	B	A
Approach Delay		51.1			71.1			15.7				13.6
Approach LOS		D			E			B				B

Intersection Summary

Area Type: Other
 Cycle Length: 138.9
 Actuated Cycle Length: 138.9
 Offset: 102 (73%), Referenced to phase 2:NBT and 6:SBT, Start of Green
 Control Type: Actuated-Coordinated
 Maximum v/c Ratio: 0.79
 Intersection Signal Delay: 17.9 Intersection LOS: B
 Intersection Capacity Utilization 68.7% ICU Level of Service C
 Analysis Period (min) 15

Splits and Phases: 4: Newport Blvd & E 16th St



Cumulative Conditions without Project - Mid-Day
5: Superior Ave & W 16th St/Industrial Way

Lanes, Volumes, Timings
Synchro 11 Report

Lane Group	EBL	EBT	EBR	WBL	WBT	WBR	NBL	NBT	NBR	SBL	SBT	SBR
Lane Configurations												
Traffic Volume (vph)	84	86	53	45	75	30	54	560	85	29	513	87
Future Volume (vph)	84	86	53	45	75	30	54	560	85	29	513	87
Ideal Flow (vphpl)	1900	1900	1900	1900	1900	1900	1900	1900	1900	1900	1900	1900
Storage Length (ft)	0		0	0		0	100		110	100		0
Storage Lanes	1		0	0		0	1		1	1		0
Taper Length (ft)	25			25			25			25		
Satd. Flow (prot)	1770	1757	0	0	1785	0	1770	3539	1583	1770	3461	0
Flt Permitted	0.950				0.985		0.310			0.341		
Satd. Flow (perm)	1770	1757	0	0	1785	0	577	3539	1583	635	3461	0
Right Turn on Red			Yes			Yes			Yes			No
Satd. Flow (RTOR)		31			10				64			
Link Speed (mph)		30			30			40				35
Link Distance (ft)		216			687			694				1138
Travel Time (s)		4.9			15.6			11.8				22.2
Peak Hour Factor	0.97	0.97	0.97	0.97	0.97	0.97	0.97	0.97	0.97	0.97	0.97	0.97
Shared Lane Traffic (%)												
Lane Group Flow (vph)	87	144	0	0	154	0	56	577	88	30	619	0
Turn Type	Split	NA		Split	NA		Perm	NA	Perm	Perm	NA	
Protected Phases	6	6		2	2			3				3
Permitted Phases							3		3	3		
Total Split (s)	56.1	56.1		35.1	35.1		30.9	30.9	30.9	30.9		30.9
Total Lost Time (s)	5.1	5.1			5.1		5.9	5.9	5.9	5.9		5.9
Act Effct Green (s)	9.6	9.6			30.0		25.0	25.0	25.0	25.0		25.0
Actuated g/C Ratio	0.12	0.12			0.37		0.31	0.31	0.31	0.31		0.31
v/c Ratio	0.41	0.61			0.23		0.31	0.53	0.16	0.15		0.58
Control Delay	38.8	37.6			18.1		28.4	25.6	9.8	23.9		26.5
Queue Delay	0.0	0.0			0.0		0.0	0.0	0.0	0.0		0.0
Total Delay	38.8	37.6			18.1		28.4	25.6	9.8	23.9		26.5
LOS	D	D			B		C	C	A	C		C
Approach Delay		38.0			18.1			23.9				26.4
Approach LOS		D			B			C				C

Intersection Summary

Area Type: Other
 Cycle Length: 122.1
 Actuated Cycle Length: 80.8
 Control Type: Actuated-Uncoordinated
 Maximum v/c Ratio: 0.61
 Intersection Signal Delay: 26.1
 Intersection LOS: C
 Intersection Capacity Utilization 54.6%
 ICU Level of Service A
 Analysis Period (min) 15

Splits and Phases: 5: Superior Ave & W 16th St/Industrial Way



Cumulative Conditions Without Project - Mid-Day
6: Industrial Way & Old Newport Blvd (W)

Intersection												
Int Delay, s/veh	3											
Movement	EBL	EBT	EBR	WBL	WBT	WBR	NBL	NBT	NBR	SBL	SBT	SBR
Lane Configurations		↕			↕			↕			↕	
Traffic Vol, veh/h	8	173	23	41	125	6	22	2	48	10	4	11
Future Vol, veh/h	8	173	23	41	125	6	22	2	48	10	4	11
Conflicting Peds, #/hr	0	0	0	0	0	0	0	0	0	0	0	0
Sign Control	Free	Free	Free	Free	Free	Free	Stop	Stop	Stop	Stop	Stop	Stop
RT Channelized	-	-	None	-	-	None	-	-	None	-	-	None
Storage Length	-	-	-	-	-	-	-	-	-	-	-	-
Veh in Median Storage, #	-	0	-	-	0	-	-	0	-	-	0	-
Grade, %	-	0	-	-	0	-	-	0	-	-	0	-
Peak Hour Factor	95	95	95	95	95	95	95	95	95	95	95	95
Heavy Vehicles, %	2	2	2	2	2	2	2	2	2	2	2	2
Mvmt Flow	8	182	24	43	132	6	23	2	51	11	4	12

Major/Minor	Major1			Major2			Minor1			Minor2		
Conflicting Flow All	138	0	0	206	0	0	439	434	194	458	443	135
Stage 1	-	-	-	-	-	-	210	210	-	221	221	-
Stage 2	-	-	-	-	-	-	229	224	-	237	222	-
Critical Hdwy	4.12	-	-	4.12	-	-	7.12	6.52	6.22	7.12	6.52	6.22
Critical Hdwy Stg 1	-	-	-	-	-	-	6.12	5.52	-	6.12	5.52	-
Critical Hdwy Stg 2	-	-	-	-	-	-	6.12	5.52	-	6.12	5.52	-
Follow-up Hdwy	2.218	-	-	2.218	-	-	3.518	4.018	3.318	3.518	4.018	3.318
Pot Cap-1 Maneuver	1446	-	-	1365	-	-	528	515	847	513	509	914
Stage 1	-	-	-	-	-	-	792	728	-	781	720	-
Stage 2	-	-	-	-	-	-	774	718	-	766	720	-
Platoon blocked, %		-	-		-	-						
Mov Cap-1 Maneuver	1446	-	-	1365	-	-	502	494	847	466	489	914
Mov Cap-2 Maneuver	-	-	-	-	-	-	502	494	-	466	489	-
Stage 1	-	-	-	-	-	-	787	724	-	776	696	-
Stage 2	-	-	-	-	-	-	734	694	-	714	716	-

Approach	EB			WB			NB			SB		
HCM Control Delay, s	0.3			1.8			10.9			11.3		
HCM LOS							B			B		

Minor Lane/Major Mvmt	NBLn1	EBL	EBT	EBR	WBL	WBT	WBR	SBLn1
Capacity (veh/h)	689	1446	-	-	1365	-	-	600
HCM Lane V/C Ratio	0.11	0.006	-	-	0.032	-	-	0.044
HCM Control Delay (s)	10.9	7.5	0	-	7.7	0	-	11.3
HCM Lane LOS	B	A	A	-	A	A	-	B
HCM 95th %tile Q(veh)	0.4	0	-	-	0.1	-	-	0.1

Cumulative Conditions without Project - Mid-Day
7: Newport Blvd & Industrial Way

Lanes, Volumes, Timings
Synchro 11 Report

Lane Group	EBL	EBT	EBR	WBL	WBT	WBR	NBL	NBT	NBR	SBL	SBT	SBR
Lane Configurations												
Traffic Volume (vph)	63	49	115	10	70	98	29	1667	14	112	1680	54
Future Volume (vph)	63	49	115	10	70	98	29	1667	14	112	1680	54
Ideal Flow (vphpl)	1900	1900	1900	1900	1900	1900	1900	1900	1900	1900	1900	1900
Storage Length (ft)	0		0	0		0	90		0	95		0
Storage Lanes	0		1	1		1	1		0	1		0
Taper Length (ft)	25			25			25			25		
Satd. Flow (prot)	0	1812	1583	1770	1863	1583	1770	5080	0	1770	5060	0
Flt Permitted		0.746		0.500			0.950			0.950		
Satd. Flow (perm)	0	1390	1583	931	1863	1583	1770	5080	0	1770	5060	0
Right Turn on Red			Yes			Yes			Yes			Yes
Satd. Flow (RTOR)			120			102		1				5
Link Speed (mph)		30			30			50				50
Link Distance (ft)		175			191			846				1146
Travel Time (s)		4.0			4.3			11.5				15.6
Peak Hour Factor	0.96	0.96	0.96	0.96	0.96	0.96	0.96	0.96	0.96	0.96	0.96	0.96
Shared Lane Traffic (%)												
Lane Group Flow (vph)	0	117	120	10	73	102	30	1751	0	117	1806	0
Turn Type	Perm	NA	Perm	Perm	NA	Perm	Prot	NA		Prot	NA	
Protected Phases		4			8		5	2		1	6	
Permitted Phases	4		4	8		8						
Total Split (s)	40.6	40.6	40.6	40.6	40.6	40.6	15.2	76.4		26.2	76.4	
Total Lost Time (s)		4.6	4.6	4.6	4.6	4.6	4.2	6.4		4.2	6.4	
Act Effct Green (s)		15.9	15.9	15.9	15.9	15.9	9.0	98.5		13.6	108.3	
Actuated g/C Ratio		0.11	0.11	0.11	0.11	0.11	0.06	0.69		0.09	0.76	
v/c Ratio		0.76	0.43	0.10	0.35	0.38	0.27	0.50		0.70	0.47	
Control Delay		90.1	13.6	56.4	62.2	13.9	70.4	12.2		83.5	8.2	
Queue Delay		0.0	0.0	0.0	0.0	0.0	0.0	0.0		0.0	0.0	
Total Delay		90.1	13.6	56.4	62.2	13.9	70.4	12.2		83.5	8.2	
LOS		F	B	E	E	B	E	B		F	A	
Approach Delay		51.4			35.2			13.2			12.8	
Approach LOS		D			D			B			B	

Intersection Summary

Area Type: Other
 Cycle Length: 143.2
 Actuated Cycle Length: 143.2
 Offset: 90 (63%), Referenced to phase 2:NBT and 6:SBT, Start of Green
 Control Type: Actuated-Coordinated
 Maximum v/c Ratio: 0.76
 Intersection Signal Delay: 16.2
 Intersection LOS: B
 Intersection Capacity Utilization 66.6%
 ICU Level of Service C
 Analysis Period (min) 15

Splits and Phases: 7: Newport Blvd & Industrial Way

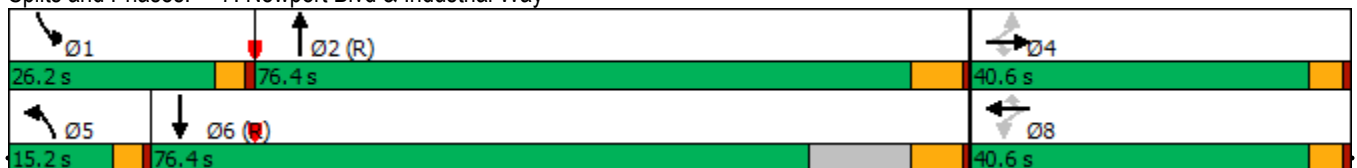

**CUMULATIVE CONDITIONS
WITHOUT PROJECT
PM PEAK HOUR**

Cumulative Conditions without Project - PM Peak Hour

Lanes, Volumes, Timings

1: Superior Ave & 17th St

Synchro 11 Report

Lane Group	EBL	EBT	EBR	WBL	WBT	WBR	NBL	NBT	NBR	SBL	SBT	SBR
Lane Configurations												
Traffic Volume (vph)	35	513	66	237	429	65	107	152	550	72	302	110
Future Volume (vph)	35	513	66	237	429	65	107	152	550	72	302	110
Ideal Flow (vphpl)	1900	1900	1900	1900	1900	1900	1900	1900	1900	1900	1900	1900
Storage Length (ft)	100		250	0		0	80		0	90		0
Storage Lanes	1		1	1		0	1		1	1		0
Taper Length (ft)	25			25			25			25		
Satd. Flow (prot)	1770	3539	1583	1770	3468	0	1770	1616	1504	1770	3398	0
Flt Permitted	0.950			0.306			0.371			0.223		
Satd. Flow (perm)	1770	3539	1583	570	3468	0	691	1616	1504	415	3398	0
Right Turn on Red			Yes			Yes			Yes			Yes
Satd. Flow (RTOR)			200		23			80	371		60	
Link Speed (mph)		35			30			35			35	
Link Distance (ft)		556			357			606			247	
Travel Time (s)		10.8			8.1			11.8			4.8	
Peak Hour Factor	0.92	0.92	0.92	0.92	0.92	0.92	0.92	0.92	0.92	0.92	0.92	0.92
Shared Lane Traffic (%)									38%			
Lane Group Flow (vph)	38	558	72	258	537	0	116	392	371	78	448	0
Turn Type	Prot	NA	Perm	pm+pt	NA		pm+pt	NA	Perm	pm+pt	NA	
Protected Phases	1	6		5	2		3	8		7	4	
Permitted Phases			6	2			8		8	4		
Total Split (s)	12.0	24.0	24.0	21.0	33.0		12.0	23.0	23.0	12.0	23.0	
Total Lost Time (s)	4.2	5.1	5.1	4.2	5.1		4.2	5.1	5.1	4.2	5.1	
Act Effct Green (s)	6.0	27.5	27.5	43.6	36.2		24.8	18.1	18.1	24.4	17.9	
Actuated g/C Ratio	0.08	0.34	0.34	0.54	0.45		0.31	0.23	0.23	0.30	0.22	
v/c Ratio	0.29	0.46	0.11	0.54	0.34		0.38	0.92	0.59	0.33	0.56	
Control Delay	40.1	24.1	0.3	15.3	16.5		20.6	53.7	7.5	20.0	26.6	
Queue Delay	0.0	0.0	0.0	0.0	0.0		0.0	0.0	0.0	0.0	0.0	
Total Delay	40.1	24.1	0.3	15.3	16.5		20.6	53.7	7.5	20.0	26.6	
LOS	D	C	A	B	B		C	D	A	B	C	
Approach Delay		22.5			16.1			29.8			25.6	
Approach LOS		C			B			C			C	

Intersection Summary

Area Type: Other
 Cycle Length: 80
 Actuated Cycle Length: 80
 Offset: 28 (35%), Referenced to phase 2:WBTL and 6:EBT, Start of Green
 Control Type: Actuated-Coordinated
 Maximum v/c Ratio: 0.92
 Intersection Signal Delay: 23.5
 Intersection LOS: C
 Intersection Capacity Utilization 66.2%
 ICU Level of Service C
 Analysis Period (min) 15

Splits and Phases: 1: Superior Ave & 17th St

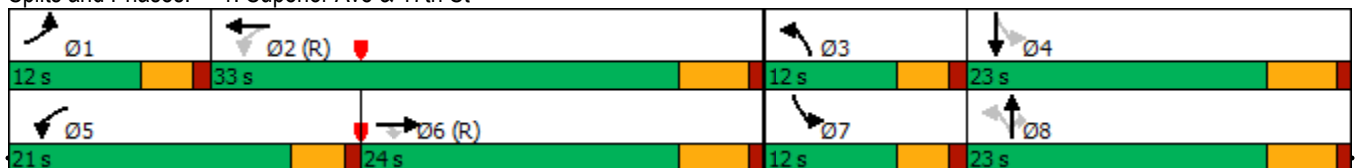

Intersection						
Int Delay, s/veh	0.9					
Movement	WBL	WBR	NBT	NBR	SBL	SBT
Lane Configurations	↔		↕↔		↕	↕↕
Traffic Vol, veh/h	22	40	760	15	26	585
Future Vol, veh/h	22	40	760	15	26	585
Conflicting Peds, #/hr	0	0	0	0	0	0
Sign Control	Stop	Stop	Free	Free	Free	Free
RT Channelized	-	None	-	None	-	None
Storage Length	0	-	-	-	65	-
Veh in Median Storage, #	0	-	0	-	-	0
Grade, %	0	-	0	-	-	0
Peak Hour Factor	84	84	84	84	84	84
Heavy Vehicles, %	2	2	2	2	2	2
Mvmt Flow	26	48	905	18	31	696

Major/Minor	Minor1	Major1	Major2		
Conflicting Flow All	1324	462	0	0	923
Stage 1	914	-	-	-	-
Stage 2	410	-	-	-	-
Critical Hdwy	6.84	6.94	-	-	4.14
Critical Hdwy Stg 1	5.84	-	-	-	-
Critical Hdwy Stg 2	5.84	-	-	-	-
Follow-up Hdwy	3.52	3.32	-	-	2.22
Pot Cap-1 Maneuver	147	547	-	-	736
Stage 1	351	-	-	-	-
Stage 2	638	-	-	-	-
Platoon blocked, %			-	-	-
Mov Cap-1 Maneuver	141	547	-	-	736
Mov Cap-2 Maneuver	261	-	-	-	-
Stage 1	351	-	-	-	-
Stage 2	611	-	-	-	-

Approach	WB	NB	SB
HCM Control Delay, s	16.2	0	0.4
HCM LOS	C		

Minor Lane/Major Mvmt	NBT	NBRWBLn1	SBL	SBT
Capacity (veh/h)	-	-	394	736
HCM Lane V/C Ratio	-	-	0.187	0.042
HCM Control Delay (s)	-	-	16.2	10.1
HCM Lane LOS	-	-	C	B
HCM 95th %tile Q(veh)	-	-	0.7	0.1

Cumulative Conditions Without Project - PM Peak Hour
 3: Old Newport Blvd (W) & E 16th St

HCM 6th TWSC
 Synchro 11 Report

Intersection												
Int Delay, s/veh	2.5											
Movement	EBL	EBT	EBR	WBL	WBT	WBR	NBL	NBT	NBR	SBL	SBT	SBR
Lane Configurations		↻			↻			↻			↻	
Traffic Vol, veh/h	1	44	1	13	65	3	2	0	10	8	1	11
Future Vol, veh/h	1	44	1	13	65	3	2	0	10	8	1	11
Conflicting Peds, #/hr	0	0	0	0	0	0	0	0	0	0	0	0
Sign Control	Free	Free	Free	Free	Free	Free	Stop	Stop	Stop	Stop	Stop	Stop
RT Channelized	-	-	None	-	-	None	-	-	None	-	-	None
Storage Length	-	-	-	-	-	-	-	-	-	-	-	-
Veh in Median Storage, #	-	0	-	-	0	-	-	0	-	-	0	-
Grade, %	-	0	-	-	0	-	-	0	-	-	0	-
Peak Hour Factor	72	72	72	72	72	72	72	72	72	72	72	72
Heavy Vehicles, %	2	2	2	2	2	2	2	2	2	2	2	2
Mvmt Flow	1	61	1	18	90	4	3	0	14	11	1	15

Major/Minor	Major1			Major2			Minor1			Minor2		
Conflicting Flow All	94	0	0	62	0	0	200	194	62	199	192	92
Stage 1	-	-	-	-	-	-	64	64	-	128	128	-
Stage 2	-	-	-	-	-	-	136	130	-	71	64	-
Critical Hdwy	4.12	-	-	4.12	-	-	7.12	6.52	6.22	7.12	6.52	6.22
Critical Hdwy Stg 1	-	-	-	-	-	-	6.12	5.52	-	6.12	5.52	-
Critical Hdwy Stg 2	-	-	-	-	-	-	6.12	5.52	-	6.12	5.52	-
Follow-up Hdwy	2.218	-	-	2.218	-	-	3.518	4.018	3.318	3.518	4.018	3.318
Pot Cap-1 Maneuver	1500	-	-	1541	-	-	759	701	1003	760	703	965
Stage 1	-	-	-	-	-	-	947	842	-	876	790	-
Stage 2	-	-	-	-	-	-	867	789	-	939	842	-
Platoon blocked, %	-	-	-	-	-	-	-	-	-	-	-	-
Mov Cap-1 Maneuver	1500	-	-	1541	-	-	739	692	1003	742	694	965
Mov Cap-2 Maneuver	-	-	-	-	-	-	739	692	-	742	694	-
Stage 1	-	-	-	-	-	-	946	841	-	875	781	-
Stage 2	-	-	-	-	-	-	842	780	-	925	841	-

Approach	EB			WB			NB			SB		
HCM Control Delay, s	0.2			1.2			8.9			9.4		
HCM LOS							A			A		

Minor Lane/Major Mvmt	NBLn1	EBL	EBT	EBR	WBL	WBT	WBR	SBLn1
Capacity (veh/h)	947	1500	-	-	1541	-	-	847
HCM Lane V/C Ratio	0.018	0.001	-	-	0.012	-	-	0.033
HCM Control Delay (s)	8.9	7.4	-	-	7.4	0	-	9.4
HCM Lane LOS	A	A	-	-	A	A	-	A
HCM 95th %tile Q(veh)	0.1	0	-	-	0	-	-	0.1

Cumulative Conditions without Project - PM Peak Hour
4: Newport Blvd & E 16th St

Lanes, Volumes, Timings
Synchro 11 Report

Lane Group	EBL	EBT	EBR	WBL	WBT	WBR	NBL	NBT	NBR	SBL	SBT	SBR
Lane Configurations												
Traffic Volume (vph)	16	32	19	85	47	53	17	1689	74	49	1718	12
Future Volume (vph)	16	32	19	85	47	53	17	1689	74	49	1718	12
Ideal Flow (vphpl)	1900	1900	1900	1900	1900	1900	1900	1900	1900	1900	1900	1900
Storage Length (ft)	0		0	0		0	95		0	85		55
Storage Lanes	0		0	0		0	1		0	1		1
Taper Length (ft)	25			25			25			25		
Satd. Flow (prot)	0	1770	0	0	1751	0	1770	5055	0	1770	5085	1583
Flt Permitted		0.872			0.817		0.950			0.950		
Satd. Flow (perm)	0	1563	0	0	1463	0	1770	5055	0	1770	5085	1583
Right Turn on Red			Yes			Yes			No			Yes
Satd. Flow (RTOR)		14			15							57
Link Speed (mph)		25			25			50				50
Link Distance (ft)		160			479			1146				979
Travel Time (s)		4.4			13.1			15.6				13.4
Peak Hour Factor	0.89	0.89	0.89	0.89	0.89	0.89	1.00	0.89	0.89	0.89	0.89	0.89
Shared Lane Traffic (%)												
Lane Group Flow (vph)	0	75	0	0	209	0	17	1981	0	55	1930	13
Turn Type	Perm	NA		Perm	NA		Prot	NA		Prot	NA	Perm
Protected Phases		4			8		5	2		1	6	
Permitted Phases	4			8								6
Total Split (s)	45.0	45.0		45.0	45.0		15.2	75.7		18.2	75.7	75.7
Total Lost Time (s)		6.0			6.0		4.2	5.7		4.2	5.7	5.7
Act Effct Green (s)		23.1			23.1		9.0	92.6		9.9	98.8	98.8
Actuated g/C Ratio		0.17			0.17		0.06	0.67		0.07	0.71	0.71
v/c Ratio		0.28			0.82		0.15	0.59		0.44	0.53	0.01
Control Delay		41.3			75.3		64.6	15.3		72.4	11.8	0.0
Queue Delay		0.0			0.0		0.0	0.0		0.0	0.0	0.0
Total Delay		41.3			75.3		64.6	15.3		72.4	11.8	0.0
LOS		D			E		E	B		E	B	A
Approach Delay		41.3			75.3			15.7				13.4
Approach LOS		D			E			B				B

Intersection Summary

Area Type: Other
 Cycle Length: 138.9
 Actuated Cycle Length: 138.9
 Offset: 98 (71%), Referenced to phase 2:NBT and 6:SBT, Start of Green
 Control Type: Actuated-Coordinated
 Maximum v/c Ratio: 0.82
 Intersection Signal Delay: 18.0
 Intersection LOS: B
 Intersection Capacity Utilization 67.6%
 ICU Level of Service C
 Analysis Period (min) 15

Splits and Phases: 4: Newport Blvd & E 16th St



Cumulative Conditions without Project - PM Peak Hour
5: Superior Ave & W 16th St/Industrial Way

Lanes, Volumes, Timings
Synchro 11 Report

Lane Group	EBL	EBT	EBR	WBL	WBT	WBR	NBL	NBT	NBR	SBL	SBT	SBR
Lane Configurations												
Traffic Volume (vph)	80	85	66	24	76	21	44	598	57	26	477	54
Future Volume (vph)	80	85	66	24	76	21	44	598	57	26	477	54
Ideal Flow (vphpl)	1900	1900	1900	1900	1900	1900	1900	1900	1900	1900	1900	1900
Storage Length (ft)	0		0	0		0	100		110	100		0
Storage Lanes	1		0	0		0	1		1	1		0
Taper Length (ft)	25			25			25			25		
Satd. Flow (prot)	1770	1742	0	0	1800	0	1770	3539	1583	1770	3486	0
Flt Permitted	0.950				0.990		0.284			0.230		
Satd. Flow (perm)	1770	1742	0	0	1800	0	529	3539	1583	428	3486	0
Right Turn on Red			Yes			Yes			Yes			No
Satd. Flow (RTOR)		39			8				64			
Link Speed (mph)		30			30			40			35	
Link Distance (ft)		216			687			694			1138	
Travel Time (s)		4.9			15.6			11.8			22.2	
Peak Hour Factor	0.82	0.82	0.82	0.82	0.82	0.82	0.82	0.82	0.82	0.82	0.82	0.82
Shared Lane Traffic (%)												
Lane Group Flow (vph)	98	184	0	0	148	0	54	729	70	32	648	0
Turn Type	Split	NA		Split	NA		Perm	NA	Perm	Perm	NA	
Protected Phases	6	6		2	2			3			3	
Permitted Phases							3		3	3		
Total Split (s)	56.1	56.1		35.1	35.1		30.9	30.9	30.9	30.9	30.9	
Total Lost Time (s)	5.1	5.1			5.1		5.9	5.9	5.9	5.9	5.9	
Act Effct Green (s)	11.3	11.3			30.0		25.0	25.0	25.0	25.0	25.0	
Actuated g/C Ratio	0.14	0.14			0.36		0.30	0.30	0.30	0.30	0.30	
v/c Ratio	0.40	0.68			0.22		0.34	0.68	0.13	0.25	0.61	
Control Delay	37.2	39.2			19.1		30.9	29.6	8.1	29.2	28.1	
Queue Delay	0.0	0.0			0.0		0.0	0.0	0.0	0.0	0.0	
Total Delay	37.2	39.2			19.1		30.9	29.6	8.1	29.2	28.1	
LOS	D	D			B		C	C	A	C	C	
Approach Delay		38.5			19.1			27.9			28.2	
Approach LOS		D			B			C			C	

Intersection Summary

Area Type: Other
 Cycle Length: 122.1
 Actuated Cycle Length: 82.5
 Control Type: Actuated-Uncoordinated
 Maximum v/c Ratio: 0.68
 Intersection Signal Delay: 28.9
 Intersection Capacity Utilization 53.3%
 Analysis Period (min) 15
 Intersection LOS: C
 ICU Level of Service A

Splits and Phases: 5: Superior Ave & W 16th St/Industrial Way



Cumulative Conditions Without Project - PM Peak Hour
6: Industrial Way & Old Newport Blvd (W)

HCM 6th TWSC
Synchro 11 Report

Intersection												
Int Delay, s/veh	1.5											
Movement	EBL	EBT	EBR	WBL	WBT	WBR	NBL	NBT	NBR	SBL	SBT	SBR
Lane Configurations		↕			↕			↕			↕	
Traffic Vol, veh/h	1	161	9	16	108	7	7	0	14	6	0	12
Future Vol, veh/h	1	161	9	16	108	7	7	0	14	6	0	12
Conflicting Peds, #/hr	0	0	0	0	0	0	0	0	0	0	0	0
Sign Control	Free	Free	Free	Free	Free	Free	Stop	Stop	Stop	Stop	Stop	Stop
RT Channelized	-	-	None	-	-	None	-	-	None	-	-	None
Storage Length	-	-	-	-	-	-	-	-	-	-	-	-
Veh in Median Storage, #	-	0	-	-	0	-	-	0	-	-	0	-
Grade, %	-	0	-	-	0	-	-	0	-	-	0	-
Peak Hour Factor	76	76	76	76	76	76	76	76	76	76	76	76
Heavy Vehicles, %	2	2	2	2	2	2	2	2	2	2	2	2
Mvmt Flow	1	212	12	21	142	9	9	0	18	8	0	16

Major/Minor	Major1			Major2			Minor1			Minor2		
Conflicting Flow All	151	0	0	224	0	0	417	413	218	418	415	147
Stage 1	-	-	-	-	-	-	220	220	-	189	189	-
Stage 2	-	-	-	-	-	-	197	193	-	229	226	-
Critical Hdwy	4.12	-	-	4.12	-	-	7.12	6.52	6.22	7.12	6.52	6.22
Critical Hdwy Stg 1	-	-	-	-	-	-	6.12	5.52	-	6.12	5.52	-
Critical Hdwy Stg 2	-	-	-	-	-	-	6.12	5.52	-	6.12	5.52	-
Follow-up Hdwy	2.218	-	-	2.218	-	-	3.518	4.018	3.318	3.518	4.018	3.318
Pot Cap-1 Maneuver	1430	-	-	1345	-	-	546	529	822	545	528	900
Stage 1	-	-	-	-	-	-	782	721	-	813	744	-
Stage 2	-	-	-	-	-	-	805	741	-	774	717	-
Platoon blocked, %	-	-	-	-	-	-	-	-	-	-	-	-
Mov Cap-1 Maneuver	1430	-	-	1345	-	-	529	519	822	525	518	900
Mov Cap-2 Maneuver	-	-	-	-	-	-	529	519	-	525	518	-
Stage 1	-	-	-	-	-	-	781	720	-	812	731	-
Stage 2	-	-	-	-	-	-	777	728	-	756	716	-

Approach	EB			WB			NB			SB		
HCM Control Delay, s	0			0.9			10.4			10.1		
HCM LOS							B			B		

Minor Lane/Major Mvmt	NBLn1	EBL	EBT	EBR	WBL	WBT	WBR	SBLn1
Capacity (veh/h)	694	1430	-	-	1345	-	-	727
HCM Lane V/C Ratio	0.04	0.001	-	-	0.016	-	-	0.033
HCM Control Delay (s)	10.4	7.5	0	-	7.7	0	-	10.1
HCM Lane LOS	B	A	A	-	A	A	-	B
HCM 95th %tile Q(veh)	0.1	0	-	-	0	-	-	0.1

Cumulative Conditions without Project - PM Peak Hour
7: Newport Blvd & Industrial Way

Lanes, Volumes, Timings
Synchro 11 Report

Lane Group	EBL	EBT	EBR	WBL	WBT	WBR	NBL	NBT	NBR	SBL	SBT	SBR
Lane Configurations												
Traffic Volume (vph)	56	56	62	12	68	109	28	1610	8	62	1717	43
Future Volume (vph)	56	56	62	12	68	109	28	1610	8	62	1717	43
Ideal Flow (vphpl)	1900	1900	1900	1900	1900	1900	1900	1900	1900	1900	1900	1900
Storage Length (ft)	0		0	0		0	90		0	95		0
Storage Lanes	0		1	1		1	1		0	1		0
Taper Length (ft)	25			25			25			25		
Satd. Flow (prot)	0	1818	1583	1770	1863	1583	1770	5080	0	1770	5065	0
Flt Permitted		0.747		0.468			0.950			0.950		
Satd. Flow (perm)	0	1391	1583	872	1863	1583	1770	5080	0	1770	5065	0
Right Turn on Red			Yes			Yes			Yes			Yes
Satd. Flow (RTOR)			90			125		1				4
Link Speed (mph)		30			30			50				50
Link Distance (ft)		175			191			846				1146
Travel Time (s)		4.0			4.3			11.5				15.6
Peak Hour Factor	0.87	0.87	0.87	0.87	0.87	0.87	0.87	0.87	0.87	0.87	0.87	0.87
Shared Lane Traffic (%)												
Lane Group Flow (vph)	0	128	71	14	78	125	32	1860	0	71	2023	0
Turn Type	Perm	NA	Perm	Perm	NA	Perm	Prot	NA		Prot	NA	
Protected Phases		4			8		5	2		1	6	
Permitted Phases	4		4	8		8						
Total Split (s)	40.6	40.6	40.6	40.6	40.6	40.6	14.2	76.4		26.2	76.4	
Total Lost Time (s)		4.6	4.6	4.6	4.6	4.6	4.2	6.4		4.2	6.4	
Act Effct Green (s)		16.6	16.6	16.6	16.6	16.6	9.1	103.5		10.6	107.6	
Actuated g/C Ratio		0.12	0.12	0.12	0.12	0.12	0.06	0.72		0.07	0.75	
v/c Ratio		0.80	0.27	0.14	0.36	0.43	0.29	0.51		0.54	0.53	
Control Delay		93.3	8.0	57.2	61.6	13.1	70.8	10.6		79.0	9.3	
Queue Delay		0.0	0.0	0.0	0.0	0.0	0.0	0.0		0.0	0.0	
Total Delay		93.3	8.0	57.2	61.6	13.1	70.8	10.6		79.0	9.3	
LOS		F	A	E	E	B	E	B		E	A	
Approach Delay		62.9			33.4			11.6			11.6	
Approach LOS		E			C			B			B	

Intersection Summary

Area Type: Other
 Cycle Length: 143.2
 Actuated Cycle Length: 143.2
 Offset: 88 (61%), Referenced to phase 2:NBT and 6:SBT, Start of Green
 Control Type: Actuated-Coordinated
 Maximum v/c Ratio: 0.80
 Intersection Signal Delay: 15.0
 Intersection LOS: B
 Intersection Capacity Utilization 67.0%
 ICU Level of Service C
 Analysis Period (min) 15

Splits and Phases: 7: Newport Blvd & Industrial Way

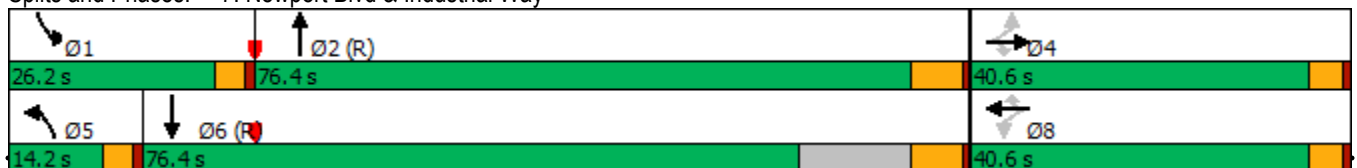

**CUMULATIVE CONDITIONS
WITHOUT PROJECT
MID-DAY (SATURDAY)**

Cumulative Conditions without Project - Mid-Day (Saturday)

Lanes, Volumes, Timings

1: Superior Ave & 17th St

Synchro 11 Report

Lane Group	EBL	EBT	EBR	WBL	WBT	WBR	NBL	NBT	NBR	SBL	SBT	SBR
Lane Configurations												
Traffic Volume (vph)	27	514	61	220	426	84	77	118	440	119	193	120
Future Volume (vph)	27	514	61	220	426	84	77	118	440	119	193	120
Ideal Flow (vphpl)	1900	1900	1900	1900	1900	1900	1900	1900	1900	1900	1900	1900
Storage Length (ft)	100		250	0		0	80		0	90		0
Storage Lanes	1		1	1		0	1		1	1		0
Taper Length (ft)	25			25			25			25		
Satd. Flow (prot)	1770	3539	1583	1770	3451	0	1770	1612	1504	1770	3337	0
Flt Permitted	0.950			0.324			0.506			0.284		
Satd. Flow (perm)	1770	3539	1583	604	3451	0	943	1612	1504	529	3337	0
Right Turn on Red			Yes			Yes			Yes			Yes
Satd. Flow (RTOR)			214		33			88	289		129	
Link Speed (mph)		35			30			35			35	
Link Distance (ft)		556			357			606			247	
Travel Time (s)		10.8			8.1			11.8			4.8	
Peak Hour Factor	0.93	0.93	0.93	0.93	0.93	0.93	0.93	0.93	0.93	0.93	0.93	0.93
Shared Lane Traffic (%)									39%			
Lane Group Flow (vph)	29	553	66	237	548	0	83	311	289	128	337	0
Turn Type	Prot	NA	Perm	pm+pt	NA		pm+pt	NA	Perm	pm+pt	NA	
Protected Phases	1	6		5	2		3	8		7	4	
Permitted Phases			6	2			8		8	4		
Total Split (s)	12.0	22.0	22.0	20.0	30.0		12.0	21.0	21.0	12.0	21.0	
Total Lost Time (s)	4.2	5.1	5.1	4.2	5.1		4.2	5.1	5.1	4.2	5.1	
Act Effct Green (s)	5.7	27.5	27.5	42.6	37.4		20.2	13.6	13.6	21.0	14.1	
Actuated g/C Ratio	0.08	0.37	0.37	0.57	0.50		0.27	0.18	0.18	0.28	0.19	
v/c Ratio	0.22	0.43	0.09	0.47	0.32		0.25	0.85	0.57	0.48	0.46	
Control Delay	36.1	21.9	0.3	13.2	13.8		17.7	43.3	8.3	23.1	18.0	
Queue Delay	0.0	0.0	0.0	0.0	0.0		0.0	0.0	0.0	0.0	0.0	
Total Delay	36.1	21.9	0.3	13.2	13.8		17.7	43.3	8.3	23.1	18.0	
LOS	D	C	A	B	B		B	D	A	C	B	
Approach Delay		20.3			13.6			25.4			19.4	
Approach LOS		C			B			C			B	

Intersection Summary

Area Type: Other
 Cycle Length: 75
 Actuated Cycle Length: 75
 Offset: 9.6 (13%), Referenced to phase 2:WBTL and 6:EBT, Start of Green
 Control Type: Actuated-Coordinated
 Maximum v/c Ratio: 0.85
 Intersection Signal Delay: 19.5 Intersection LOS: B
 Intersection Capacity Utilization 63.7% ICU Level of Service B
 Analysis Period (min) 15

Splits and Phases: 1: Superior Ave & 17th St



Cumulative Conditions Without Project - Mid-Day (Saturday)
 2: Superior Ave & E 16th St

HCM 6th TWSC
 Synchro 11 Report

Intersection						
Int Delay, s/veh	1.1					
Movement	WBL	WBR	NBT	NBR	SBL	SBT
Lane Configurations	↔		↕↔		↕	↕↕
Traffic Vol, veh/h	31	43	600	18	31	465
Future Vol, veh/h	31	43	600	18	31	465
Conflicting Peds, #/hr	0	0	0	0	0	0
Sign Control	Stop	Stop	Free	Free	Free	Free
RT Channelized	-	None	-	None	-	None
Storage Length	0	-	-	-	65	-
Veh in Median Storage, #	0	-	0	-	-	0
Grade, %	0	-	0	-	-	0
Peak Hour Factor	92	100	92	92	92	92
Heavy Vehicles, %	2	2	2	2	2	2
Mvmt Flow	34	43	652	20	34	505

Major/Minor	Minor1	Major1	Major2		
Conflicting Flow All	983	336	0	0	672
Stage 1	662	-	-	-	-
Stage 2	321	-	-	-	-
Critical Hdwy	6.84	6.94	-	-	4.14
Critical Hdwy Stg 1	5.84	-	-	-	-
Critical Hdwy Stg 2	5.84	-	-	-	-
Follow-up Hdwy	3.52	3.32	-	-	2.22
Pot Cap-1 Maneuver	246	660	-	-	915
Stage 1	475	-	-	-	-
Stage 2	708	-	-	-	-
Platoon blocked, %			-	-	-
Mov Cap-1 Maneuver	237	660	-	-	915
Mov Cap-2 Maneuver	358	-	-	-	-
Stage 1	475	-	-	-	-
Stage 2	682	-	-	-	-

Approach	WB	NB	SB
HCM Control Delay, s	13.9	0	0.6
HCM LOS	B		

Minor Lane/Major Mvmt	NBT	NBRWBLn1	SBL	SBT
Capacity (veh/h)	-	-	482	915
HCM Lane V/C Ratio	-	-	0.159	0.037
HCM Control Delay (s)	-	-	13.9	9.1
HCM Lane LOS	-	-	B	A
HCM 95th %tile Q(veh)	-	-	0.6	0.1

Cumulative Conditions Without Project - Mid-Day (Saturday)
 3: Old Newport Blvd (W) & E 16th St

HCM 6th TWSC
 Synchro 11 Report

Intersection												
Int Delay, s/veh	2.4											
Movement	EBL	EBT	EBR	WBL	WBT	WBR	NBL	NBT	NBR	SBL	SBT	SBR
Lane Configurations		↔			↔			↔			↔	
Traffic Vol, veh/h	3	42	6	16	74	8	2	0	19	9	0	3
Future Vol, veh/h	3	42	6	16	74	8	2	0	19	9	0	3
Conflicting Peds, #/hr	0	0	0	0	0	0	0	0	0	0	0	0
Sign Control	Free	Free	Free	Free	Free	Free	Stop	Stop	Stop	Stop	Stop	Stop
RT Channelized	-	-	None	-	-	None	-	-	None	-	-	None
Storage Length	-	-	-	-	-	-	-	-	-	-	-	-
Veh in Median Storage, #	-	0	-	-	0	-	-	0	-	-	0	-
Grade, %	-	0	-	-	0	-	-	0	-	-	0	-
Peak Hour Factor	94	94	94	94	94	94	94	94	94	94	94	94
Heavy Vehicles, %	2	2	2	2	2	2	2	2	2	2	2	2
Mvmt Flow	3	45	6	17	79	9	2	0	20	10	0	3

Major/Minor	Major1			Major2			Minor1			Minor2		
Conflicting Flow All	88	0	0	51	0	0	173	176	48	182	175	84
Stage 1	-	-	-	-	-	-	54	54	-	118	118	-
Stage 2	-	-	-	-	-	-	119	122	-	64	57	-
Critical Hdwy	4.12	-	-	4.12	-	-	7.12	6.52	6.22	7.12	6.52	6.22
Critical Hdwy Stg 1	-	-	-	-	-	-	6.12	5.52	-	6.12	5.52	-
Critical Hdwy Stg 2	-	-	-	-	-	-	6.12	5.52	-	6.12	5.52	-
Follow-up Hdwy	2.218	-	-	2.218	-	-	3.518	4.018	3.318	3.518	4.018	3.318
Pot Cap-1 Maneuver	1508	-	-	1555	-	-	790	717	1021	779	718	975
Stage 1	-	-	-	-	-	-	958	850	-	887	798	-
Stage 2	-	-	-	-	-	-	885	795	-	947	847	-
Platoon blocked, %	-	-	-	-	-	-	-	-	-	-	-	-
Mov Cap-1 Maneuver	1508	-	-	1555	-	-	779	707	1021	756	708	975
Mov Cap-2 Maneuver	-	-	-	-	-	-	779	707	-	756	708	-
Stage 1	-	-	-	-	-	-	956	848	-	885	788	-
Stage 2	-	-	-	-	-	-	872	785	-	926	845	-

Approach	EB			WB			NB			SB		
HCM Control Delay, s	0.4			1.2			8.7			9.6		
HCM LOS							A			A		

Minor Lane/Major Mvmt	NBLn1	EBL	EBT	EBR	WBL	WBT	WBR	SBLn1
Capacity (veh/h)	992	1508	-	-	1555	-	-	801
HCM Lane V/C Ratio	0.023	0.002	-	-	0.011	-	-	0.016
HCM Control Delay (s)	8.7	7.4	-	-	7.3	0	-	9.6
HCM Lane LOS	A	A	-	-	A	A	-	A
HCM 95th %tile Q(veh)	0.1	0	-	-	0	-	-	0

Cumulative Conditions without Project - Mid-Day (Saturday)

Lanes, Volumes, Timings

4: Newport Blvd & E 16th St

Synchro 11 Report

Lane Group	EBL	EBT	EBR	WBL	WBT	WBR	NBL	NBT	NBR	SBL	SBT	SBR
Lane Configurations												
Traffic Volume (vph)	21	28	16	80	47	81	16	1865	80	51	1969	14
Future Volume (vph)	21	28	16	80	47	81	16	1865	80	51	1969	14
Ideal Flow (vphpl)	1900	1900	1900	1900	1900	1900	1900	1900	1900	1900	1900	1900
Storage Length (ft)	0		0	0		0	95		0	85		55
Storage Lanes	0		0	0		0	1		0	1		1
Taper Length (ft)	25			25			25			25		
Satd. Flow (prot)	0	1772	0	0	1731	0	1770	5055	0	1770	5085	1583
Flt Permitted		0.790			0.851		0.950			0.950		
Satd. Flow (perm)	0	1423	0	0	1501	0	1770	5055	0	1770	5085	1583
Right Turn on Red			Yes			Yes			No			Yes
Satd. Flow (RTOR)		11			23							56
Link Speed (mph)		25			25			50			50	
Link Distance (ft)		160			479			1146			979	
Travel Time (s)		4.4			13.1			15.6			13.4	
Peak Hour Factor	0.92	0.92	0.92	0.92	0.92	0.92	0.92	0.92	0.92	0.92	0.92	0.92
Shared Lane Traffic (%)												
Lane Group Flow (vph)	0	70	0	0	226	0	17	2114	0	55	2140	15
Turn Type	Perm	NA		Perm	NA		Prot	NA		Prot	NA	Perm
Protected Phases		4			8		5	2		1	6	
Permitted Phases	4			8								6
Total Split (s)	45.0	45.0		45.0	45.0		18.2	75.7		19.2	75.7	75.7
Total Lost Time (s)		6.0			6.0		4.2	5.7		4.2	5.7	5.7
Act Effct Green (s)		23.8			23.8		9.0	92.8		10.0	99.1	99.1
Actuated g/C Ratio		0.17			0.17		0.06	0.66		0.07	0.71	0.71
v/c Ratio		0.28			0.82		0.15	0.63		0.44	0.59	0.01
Control Delay		42.9			72.8		65.2	16.6		73.1	13.1	0.0
Queue Delay		0.0			0.0		0.0	0.0		0.0	0.0	0.0
Total Delay		42.9			72.8		65.2	16.6		73.1	13.1	0.0
LOS		D			E		E	B		E	B	A
Approach Delay		42.9			72.8			16.9			14.5	
Approach LOS		D			E			B			B	

Intersection Summary

Area Type: Other
 Cycle Length: 139.9
 Actuated Cycle Length: 139.9
 Offset: 103 (74%), Referenced to phase 2:NBT and 6:SBT, Start of Green
 Control Type: Actuated-Coordinated
 Maximum v/c Ratio: 0.82
 Intersection Signal Delay: 18.9 Intersection LOS: B
 Intersection Capacity Utilization 68.9% ICU Level of Service C
 Analysis Period (min) 15

Splits and Phases: 4: Newport Blvd & E 16th St



Cumulative Conditions without Project - Mid-Day (Saturday)
 5: Superior Ave & W 16th St/Industrial Way

Lanes, Volumes, Timings
 Synchro 11 Report

Lane Group	EBL	EBT	EBR	WBL	WBT	WBR	NBL	NBT	NBR	SBL	SBT	SBR
Lane Configurations												
Traffic Volume (vph)	71	88	74	20	54	33	23	477	29	25	369	62
Future Volume (vph)	71	88	74	20	54	33	23	477	29	25	369	62
Ideal Flow (vphpl)	1900	1900	1900	1900	1900	1900	1900	1900	1900	1900	1900	1900
Storage Length (ft)	0		0	0		0	100		110	100		0
Storage Lanes	1		0	0		0	1		1	1		0
Taper Length (ft)	25			25			25			25		
Satd. Flow (prot)	1770	1736	0	0	1768	0	1770	3539	1583	1770	3461	0
Flt Permitted	0.950				0.991		0.437			0.396		
Satd. Flow (perm)	1770	1736	0	0	1768	0	814	3539	1583	738	3461	0
Right Turn on Red			Yes			Yes			Yes			No
Satd. Flow (RTOR)		42			18				64			
Link Speed (mph)		30			30			40			35	
Link Distance (ft)		216			687			694			1138	
Travel Time (s)		4.9			15.6			11.8			22.2	
Peak Hour Factor	0.95	0.95	0.95	0.95	0.95	0.95	0.95	0.95	0.95	0.95	0.95	0.95
Shared Lane Traffic (%)												
Lane Group Flow (vph)	75	171	0	0	113	0	24	502	31	26	453	0
Turn Type	Split	NA		Split	NA		Perm	NA	Perm	Perm	NA	
Protected Phases	6	6		2	2			3			3	
Permitted Phases							3		3	3		
Total Split (s)	56.1	56.1		35.1	35.1		30.9	30.9	30.9	30.9	30.9	
Total Lost Time (s)	5.1	5.1			5.1		5.9	5.9	5.9	5.9	5.9	
Act Effct Green (s)	10.5	10.5			30.0		25.0	25.0	25.0	25.0	25.0	
Actuated g/C Ratio	0.13	0.13			0.37		0.31	0.31	0.31	0.31	0.31	
v/c Ratio	0.33	0.66			0.17		0.10	0.46	0.06	0.12	0.43	
Control Delay	36.0	37.8			16.3		23.0	25.1	1.9	23.5	24.7	
Queue Delay	0.0	0.0			0.0		0.0	0.0	0.0	0.0	0.0	
Total Delay	36.0	37.8			16.3		23.0	25.1	1.9	23.5	24.7	
LOS	D	D			B		C	C	A	C	C	
Approach Delay		37.2			16.3			23.8			24.6	
Approach LOS		D			B			C			C	

Intersection Summary

Area Type: Other
 Cycle Length: 122.1
 Actuated Cycle Length: 81.7
 Control Type: Actuated-Uncoordinated
 Maximum v/c Ratio: 0.66
 Intersection Signal Delay: 25.8
 Intersection LOS: C
 Intersection Capacity Utilization 49.3%
 ICU Level of Service A
 Analysis Period (min) 15

Splits and Phases: 5: Superior Ave & W 16th St/Industrial Way



Cumulative Conditions Without Project - Mid-Day (Saturday)
6: Industrial Way & Old Newport Blvd (W)

HCM 6th TWSC
Synchro 11 Report

Intersection												
Int Delay, s/veh	2.2											
Movement	EBL	EBT	EBR	WBL	WBT	WBR	NBL	NBT	NBR	SBL	SBT	SBR
Lane Configurations		↕			↕			↕			↕	
Traffic Vol, veh/h	2	129	16	24	81	5	13	0	21	3	0	12
Future Vol, veh/h	2	129	16	24	81	5	13	0	21	3	0	12
Conflicting Peds, #/hr	0	0	0	0	0	0	0	0	0	0	0	0
Sign Control	Free	Free	Free	Free	Free	Free	Stop	Stop	Stop	Stop	Stop	Stop
RT Channelized	-	-	None	-	-	None	-	-	None	-	-	None
Storage Length	-	-	-	-	-	-	-	-	-	-	-	-
Veh in Median Storage, #	-	0	-	-	0	-	-	0	-	-	0	-
Grade, %	-	0	-	-	0	-	-	0	-	-	0	-
Peak Hour Factor	89	89	89	89	89	89	89	89	89	89	89	89
Heavy Vehicles, %	2	2	2	2	2	2	2	2	2	2	2	2
Mvmt Flow	2	145	18	27	91	6	15	0	24	3	0	13

Major/Minor	Major1			Major2			Minor1			Minor2		
Conflicting Flow All	97	0	0	163	0	0	313	309	154	318	315	94
Stage 1	-	-	-	-	-	-	158	158	-	148	148	-
Stage 2	-	-	-	-	-	-	155	151	-	170	167	-
Critical Hdwy	4.12	-	-	4.12	-	-	7.12	6.52	6.22	7.12	6.52	6.22
Critical Hdwy Stg 1	-	-	-	-	-	-	6.12	5.52	-	6.12	5.52	-
Critical Hdwy Stg 2	-	-	-	-	-	-	6.12	5.52	-	6.12	5.52	-
Follow-up Hdwy	2.218	-	-	2.218	-	-	3.518	4.018	3.318	3.518	4.018	3.318
Pot Cap-1 Maneuver	1496	-	-	1416	-	-	640	605	892	635	601	963
Stage 1	-	-	-	-	-	-	844	767	-	855	775	-
Stage 2	-	-	-	-	-	-	847	772	-	832	760	-
Platoon blocked, %	-	-	-	-	-	-	-	-	-	-	-	-
Mov Cap-1 Maneuver	1496	-	-	1416	-	-	621	592	892	608	588	963
Mov Cap-2 Maneuver	-	-	-	-	-	-	621	592	-	608	588	-
Stage 1	-	-	-	-	-	-	843	766	-	854	760	-
Stage 2	-	-	-	-	-	-	818	757	-	809	759	-

Approach	EB			WB			NB			SB		
HCM Control Delay, s	0.1			1.7			10			9.3		
HCM LOS							B			A		

Minor Lane/Major Mvmt	NBLn1	EBL	EBT	EBR	WBL	WBT	WBR	SBLn1
Capacity (veh/h)	764	1496	-	-	1416	-	-	862
HCM Lane V/C Ratio	0.05	0.002	-	-	0.019	-	-	0.02
HCM Control Delay (s)	10	7.4	0	-	7.6	0	-	9.3
HCM Lane LOS	B	A	A	-	A	A	-	A
HCM 95th %tile Q(veh)	0.2	0	-	-	0.1	-	-	0.1

Cumulative Conditions without Project - Mid-Day (Saturday)
 7: Newport Blvd & Industrial Way

Lanes, Volumes, Timings
 Synchro 11 Report

Lane Group	EBL	EBT	EBR	WBL	WBT	WBR	NBL	NBT	NBR	SBL	SBT	SBR
Lane Configurations												
Traffic Volume (vph)	34	52	66	11	41	64	26	1870	16	43	1973	37
Future Volume (vph)	34	52	66	11	41	64	26	1870	16	43	1973	37
Ideal Flow (vphpl)	1900	1900	1900	1900	1900	1900	1900	1900	1900	1900	1900	1900
Storage Length (ft)	0		0	0		0	90		0	95		0
Storage Lanes	0		1	1		1	1		0	1		0
Taper Length (ft)	25			25			25			25		
Satd. Flow (prot)	0	1827	1583	1770	1863	1583	1770	5080	0	1770	5070	0
Flt Permitted		0.852		0.594			0.950			0.950		
Satd. Flow (perm)	0	1587	1583	1106	1863	1583	1770	5080	0	1770	5070	0
Right Turn on Red			Yes			Yes			Yes			Yes
Satd. Flow (RTOR)			94			94		1			3	
Link Speed (mph)		30			30			50			50	
Link Distance (ft)		175			191			846			1146	
Travel Time (s)		4.0			4.3			11.5			15.6	
Peak Hour Factor	0.96	0.96	0.96	0.96	0.96	0.96	0.96	0.96	0.96	0.96	0.96	0.96
Shared Lane Traffic (%)												
Lane Group Flow (vph)	0	89	69	11	43	67	27	1965	0	45	2094	0
Turn Type	Perm	NA	Perm	Perm	NA	Perm	Prot	NA		Prot	NA	
Protected Phases		4			8		5	2		1	6	
Permitted Phases	4		4	8		8						
Total Split (s)	40.6	40.6	40.6	40.6	40.6	40.6	15.2	76.4		20.2	76.4	
Total Lost Time (s)		4.6	4.6	4.6	4.6	4.6	4.2	6.4		4.2	6.4	
Act Effct Green (s)		12.5	12.5	12.5	12.5	12.5	9.0	102.7		9.4	105.7	
Actuated g/C Ratio		0.09	0.09	0.09	0.09	0.09	0.07	0.75		0.07	0.77	
v/c Ratio		0.62	0.30	0.11	0.25	0.29	0.23	0.52		0.37	0.54	
Control Delay		77.8	8.0	57.8	60.6	7.5	66.0	8.4		70.1	7.7	
Queue Delay		0.0	0.0	0.0	0.0	0.0	0.0	0.0		0.0	0.0	
Total Delay		77.8	8.0	57.8	60.6	7.5	66.0	8.4		70.1	7.7	
LOS		E	A	E	E	A	E	A		E	A	
Approach Delay		47.3			30.9			9.2			9.0	
Approach LOS		D			C			A			A	

Intersection Summary

Area Type: Other
 Cycle Length: 137.2
 Actuated Cycle Length: 137.2
 Offset: 102 (74%), Referenced to phase 2:NBT and 6:SBT, Start of Green
 Control Type: Actuated-Coordinated
 Maximum v/c Ratio: 0.62
 Intersection Signal Delay: 11.1 Intersection LOS: B
 Intersection Capacity Utilization 68.6% ICU Level of Service C
 Analysis Period (min) 15

Splits and Phases: 7: Newport Blvd & Industrial Way



**CUMULATIVE CONDITIONS
WITH PROJECT
MID-DAY**

Cumulative Conditions with Project - Mid-Day
1: Superior Ave & 17th St

Lanes, Volumes, Timings
Synchro 11 Report

Lane Group	EBL	EBT	EBR	WBL	WBT	WBR	NBL	NBT	NBR	SBL	SBT	SBR
Lane Configurations												
Traffic Volume (vph)	54	591	76	218	462	73	112	160	528	102	321	99
Future Volume (vph)	54	591	76	218	462	73	112	160	528	102	321	99
Ideal Flow (vphpl)	1900	1900	1900	1900	1900	1900	1900	1900	1900	1900	1900	1900
Storage Length (ft)	100		250	0		0	80		0	90		0
Storage Lanes	1		1	1		0	1		1	1		0
Taper Length (ft)	25			25			25			25		
Satd. Flow (prot)	1770	3539	1583	1770	3465	0	1770	1624	1504	1770	3415	0
Flt Permitted	0.950			0.287			0.404			0.255		
Satd. Flow (perm)	1770	3539	1583	535	3465	0	753	1624	1504	475	3415	0
Right Turn on Red			Yes			Yes			Yes			Yes
Satd. Flow (RTOR)			214		25			74	336		50	
Link Speed (mph)		35			30			35			35	
Link Distance (ft)		556			357			606			247	
Travel Time (s)		10.8			8.1			11.8			4.8	
Peak Hour Factor	0.99	0.99	0.99	0.99	0.99	0.99	0.99	0.99	0.99	0.99	0.99	0.99
Shared Lane Traffic (%)									37%			
Lane Group Flow (vph)	55	597	77	220	541	0	113	359	336	103	424	0
Turn Type	Prot	NA	Perm	pm+pt	NA		pm+pt	NA	Perm	pm+pt	NA	
Protected Phases	1	6		5	2		3	8		7	4	
Permitted Phases			6	2			8		8	4		
Total Split (s)	12.0	22.0	22.0	20.0	30.0		12.0	21.0	21.0	12.0	21.0	
Total Lost Time (s)	4.2	5.1	5.1	4.2	5.1		4.2	5.1	5.1	4.2	5.1	
Act Effct Green (s)	6.3	26.2	26.2	40.8	33.3		22.1	15.5	15.5	22.4	15.6	
Actuated g/C Ratio	0.08	0.35	0.35	0.54	0.44		0.29	0.21	0.21	0.30	0.21	
v/c Ratio	0.37	0.48	0.11	0.49	0.35		0.36	0.91	0.58	0.40	0.57	
Control Delay	39.3	22.9	0.3	14.0	16.4		19.3	53.0	7.9	20.4	26.5	
Queue Delay	0.0	0.0	0.0	0.0	0.0		0.0	0.0	0.0	0.0	0.0	
Total Delay	39.3	22.9	0.3	14.0	16.4		19.3	53.0	7.9	20.4	26.5	
LOS	D	C	A	B	B		B	D	A	C	C	
Approach Delay		21.7			15.7			29.5			25.3	
Approach LOS		C			B			C			C	

Intersection Summary

Area Type: Other
 Cycle Length: 75
 Actuated Cycle Length: 75
 Offset: 28 (37%), Referenced to phase 2:WBTL and 6:EBT, Start of Green
 Control Type: Actuated-Coordinated
 Maximum v/c Ratio: 0.91
 Intersection Signal Delay: 23.0 Intersection LOS: C
 Intersection Capacity Utilization 68.8% ICU Level of Service C
 Analysis Period (min) 15

Splits and Phases: 1: Superior Ave & 17th St

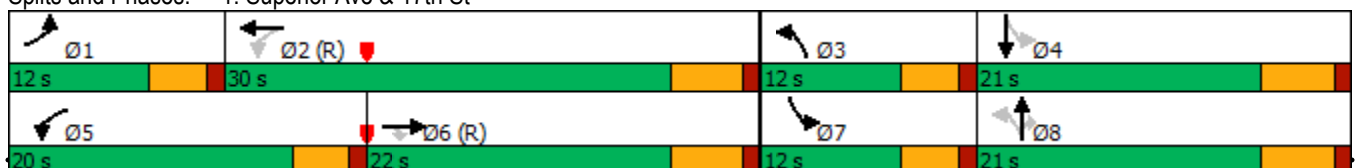

Intersection						
Int Delay, s/veh	1.2					
Movement	WBL	WBR	NBT	NBR	SBL	SBT
Lane Configurations	↔		↕		↔	↕
Traffic Vol, veh/h	35	50	728	19	57	649
Future Vol, veh/h	35	50	728	19	57	649
Conflicting Peds, #/hr	0	0	0	0	0	0
Sign Control	Stop	Stop	Free	Free	Free	Free
RT Channelized	-	None	-	None	-	None
Storage Length	0	-	-	-	65	-
Veh in Median Storage, #	0	-	0	-	-	0
Grade, %	0	-	0	-	-	0
Peak Hour Factor	97	97	97	97	97	97
Heavy Vehicles, %	2	2	2	2	2	2
Mvmt Flow	36	52	751	20	59	669

Major/Minor	Minor1	Major1	Major2		
Conflicting Flow All	1214	386	0	0	771
Stage 1	761	-	-	-	-
Stage 2	453	-	-	-	-
Critical Hdwy	6.84	6.94	-	-	4.14
Critical Hdwy Stg 1	5.84	-	-	-	-
Critical Hdwy Stg 2	5.84	-	-	-	-
Follow-up Hdwy	3.52	3.32	-	-	2.22
Pot Cap-1 Maneuver	174	612	-	-	840
Stage 1	422	-	-	-	-
Stage 2	607	-	-	-	-
Platoon blocked, %			-	-	-
Mov Cap-1 Maneuver	162	612	-	-	840
Mov Cap-2 Maneuver	292	-	-	-	-
Stage 1	422	-	-	-	-
Stage 2	565	-	-	-	-

Approach	WB	NB	SB
HCM Control Delay, s	15.8	0	0.8
HCM LOS	C		

Minor Lane/Major Mvmt	NBT	NBRWBLn1	SBL	SBT
Capacity (veh/h)	-	-	422	840
HCM Lane V/C Ratio	-	-	0.208	0.07
HCM Control Delay (s)	-	-	15.8	9.6
HCM Lane LOS	-	-	C	A
HCM 95th %tile Q(veh)	-	-	0.8	0.2

Cumulative Conditions With Project - Mid-Day
 3: Old Newport Blvd (W) & E 16th St

HCM 6th TWSC
 Synchro 11 Report

Intersection												
Int Delay, s/veh	3.9											
Movement	EBL	EBT	EBR	WBL	WBT	WBR	NBL	NBT	NBR	SBL	SBT	SBR
Lane Configurations		↻			↻			↻			↻	
Traffic Vol, veh/h	3	56	13	53	67	7	8	0	45	9	3	0
Future Vol, veh/h	3	56	13	53	67	7	8	0	45	9	3	0
Conflicting Peds, #/hr	0	0	0	0	0	0	0	0	0	0	0	0
Sign Control	Free	Free	Free	Free	Free	Free	Stop	Stop	Stop	Stop	Stop	Stop
RT Channelized	-	-	None	-	-	None	-	-	None	-	-	None
Storage Length	-	-	-	-	-	-	-	-	-	-	-	-
Veh in Median Storage, #	-	0	-	-	0	-	-	0	-	-	0	-
Grade, %	-	0	-	-	0	-	-	0	-	-	0	-
Peak Hour Factor	91	91	91	91	91	91	91	91	91	91	91	91
Heavy Vehicles, %	2	2	2	2	2	2	2	2	2	2	2	2
Mvmt Flow	3	62	14	58	74	8	9	0	49	10	3	0

Major/Minor	Major1			Major2			Minor1			Minor2		
Conflicting Flow All	82	0	0	76	0	0	271	273	69	294	276	78
Stage 1	-	-	-	-	-	-	75	75	-	194	194	-
Stage 2	-	-	-	-	-	-	196	198	-	100	82	-
Critical Hdwy	4.12	-	-	4.12	-	-	7.12	6.52	6.22	7.12	6.52	6.22
Critical Hdwy Stg 1	-	-	-	-	-	-	6.12	5.52	-	6.12	5.52	-
Critical Hdwy Stg 2	-	-	-	-	-	-	6.12	5.52	-	6.12	5.52	-
Follow-up Hdwy	2.218	-	-	2.218	-	-	3.518	4.018	3.318	3.518	4.018	3.318
Pot Cap-1 Maneuver	1515	-	-	1523	-	-	682	634	994	658	632	983
Stage 1	-	-	-	-	-	-	934	833	-	808	740	-
Stage 2	-	-	-	-	-	-	806	737	-	906	827	-
Platoon blocked, %	-	-	-	-	-	-	-	-	-	-	-	-
Mov Cap-1 Maneuver	1515	-	-	1523	-	-	657	607	994	605	605	983
Mov Cap-2 Maneuver	-	-	-	-	-	-	657	607	-	605	605	-
Stage 1	-	-	-	-	-	-	932	831	-	806	710	-
Stage 2	-	-	-	-	-	-	770	708	-	859	825	-

Approach	EB			WB			NB			SB		
HCM Control Delay, s	0.3			3.1			9.2			11.1		
HCM LOS							A			B		

Minor Lane/Major Mvmt	NBLn1	EBL	EBT	EBR	WBL	WBT	WBR	SBLn1
Capacity (veh/h)	923	1515	-	-	1523	-	-	605
HCM Lane V/C Ratio	0.063	0.002	-	-	0.038	-	-	0.022
HCM Control Delay (s)	9.2	7.4	-	-	7.5	0	-	11.1
HCM Lane LOS	A	A	-	-	A	A	-	B
HCM 95th %tile Q(veh)	0.2	0	-	-	0.1	-	-	0.1

Cumulative Conditions with Project - Mid-Day
4: Newport Blvd & E 16th St

Lanes, Volumes, Timings
Synchro 11 Report

Lane Group	EBL	EBT	EBR	WBL	WBT	WBR	NBL	NBT	NBR	SBL	SBT	SBR
Lane Configurations												
Traffic Volume (vph)	44	28	24	68	42	77	44	1750	87	81	1729	42
Future Volume (vph)	44	28	24	68	42	77	44	1750	87	81	1729	42
Ideal Flow (vphpl)	1900	1900	1900	1900	1900	1900	1900	1900	1900	1900	1900	1900
Storage Length (ft)	0		0	0		0	95		0	85		55
Storage Lanes	0		0	0		0	1		0	1		1
Taper Length (ft)	25			25			25			25		
Satd. Flow (prot)	0	1760	0	0	1727	0	1770	5050	0	1770	5085	1583
Flt Permitted		0.644			0.821		0.950			0.950		
Satd. Flow (perm)	0	1159	0	0	1444	0	1770	5050	0	1770	5085	1583
Right Turn on Red			Yes			Yes			No			Yes
Satd. Flow (RTOR)		12			25							57
Link Speed (mph)		25			25			50			50	
Link Distance (ft)		160			479			1146			979	
Travel Time (s)		4.4			13.1			15.6			13.4	
Peak Hour Factor	0.97	0.97	0.97	0.97	0.97	0.97	0.97	0.97	0.97	0.97	0.97	0.97
Shared Lane Traffic (%)												
Lane Group Flow (vph)	0	99	0	0	192	0	45	1894	0	84	1782	43
Turn Type	Perm	NA		Perm	NA		Prot	NA		Prot	NA	Perm
Protected Phases		4			8		5	2		1	6	
Permitted Phases	4			8								6
Total Split (s)	45.0	45.0		45.0	45.0		15.2	75.7		18.2	75.7	75.7
Total Lost Time (s)		6.0			6.0		4.2	5.7		4.2	5.7	5.7
Act Effct Green (s)		20.4			20.4		9.5	91.1		11.5	95.7	95.7
Actuated g/C Ratio		0.15			0.15		0.07	0.66		0.08	0.69	0.69
v/c Ratio		0.55			0.82		0.37	0.57		0.58	0.51	0.04
Control Delay		58.2			75.9		70.7	15.2		76.4	12.4	1.8
Queue Delay		0.0			0.0		0.0	0.0		0.0	0.0	0.0
Total Delay		58.2			75.9		70.7	15.2		76.4	12.4	1.8
LOS		E			E		E	B		E	B	A
Approach Delay		58.2			75.9			16.5			14.9	
Approach LOS		E			E			B			B	

Intersection Summary

Area Type: Other
 Cycle Length: 138.9
 Actuated Cycle Length: 138.9
 Offset: 102 (73%), Referenced to phase 2:NBT and 6:SBT, Start of Green
 Control Type: Actuated-Coordinated
 Maximum v/c Ratio: 0.82
 Intersection Signal Delay: 19.5 Intersection LOS: B
 Intersection Capacity Utilization 69.1% ICU Level of Service C
 Analysis Period (min) 15

Splits and Phases: 4: Newport Blvd & E 16th St



Cumulative Conditions with Project - Mid-Day
5: Superior Ave & W 16th St/Industrial Way

Lanes, Volumes, Timings
Synchro 11 Report

Lane Group	EBL	EBT	EBR	WBL	WBT	WBR	NBL	NBT	NBR	SBL	SBT	SBR
Lane Configurations												
Traffic Volume (vph)	84	88	53	47	77	30	54	560	87	29	513	87
Future Volume (vph)	84	88	53	47	77	30	54	560	87	29	513	87
Ideal Flow (vphpl)	1900	1900	1900	1900	1900	1900	1900	1900	1900	1900	1900	1900
Storage Length (ft)	0		0	0		0	100		110	100		0
Storage Lanes	1		0	0		0	1		1	1		0
Taper Length (ft)	25			25			25			25		
Satd. Flow (prot)	1770	1757	0	0	1787	0	1770	3539	1583	1770	3461	0
Flt Permitted	0.950				0.985		0.310			0.340		
Satd. Flow (perm)	1770	1757	0	0	1787	0	577	3539	1583	633	3461	0
Right Turn on Red			Yes			Yes			Yes			No
Satd. Flow (RTOR)		31			10				64			
Link Speed (mph)		30			30			40				35
Link Distance (ft)		216			687			694				1138
Travel Time (s)		4.9			15.6			11.8				22.2
Peak Hour Factor	0.97	0.97	0.97	0.97	0.97	0.97	0.97	0.97	0.97	0.97	0.97	0.97
Shared Lane Traffic (%)												
Lane Group Flow (vph)	87	146	0	0	158	0	56	577	90	30	619	0
Turn Type	Split	NA		Split	NA		Perm	NA	Perm	Perm	NA	
Protected Phases	6	6		2	2			3			3	
Permitted Phases							3		3	3		
Total Split (s)	56.1	56.1		35.1	35.1		30.9	30.9	30.9	30.9	30.9	
Total Lost Time (s)	5.1	5.1			5.1		5.9	5.9	5.9	5.9	5.9	
Act Effct Green (s)	9.7	9.7			30.0		25.0	25.0	25.0	25.0	25.0	
Actuated g/C Ratio	0.12	0.12			0.37		0.31	0.31	0.31	0.31	0.31	
v/c Ratio	0.41	0.61			0.24		0.31	0.53	0.17	0.15	0.58	
Control Delay	38.6	37.8			18.2		28.5	25.6	10.0	24.0	26.6	
Queue Delay	0.0	0.0			0.0		0.0	0.0	0.0	0.0	0.0	
Total Delay	38.6	37.8			18.2		28.5	25.6	10.0	24.0	26.6	
LOS	D	D			B		C	C	A	C	C	
Approach Delay		38.1			18.2			23.9			26.4	
Approach LOS		D			B			C			C	

Intersection Summary

Area Type: Other
 Cycle Length: 122.1
 Actuated Cycle Length: 80.9
 Control Type: Actuated-Uncoordinated
 Maximum v/c Ratio: 0.61
 Intersection Signal Delay: 26.2
 Intersection LOS: C
 Intersection Capacity Utilization 55.0%
 ICU Level of Service A
 Analysis Period (min) 15

Splits and Phases: 5: Superior Ave & W 16th St/Industrial Way



Cumulative Conditions With Project - Mid-Day
6: Industrial Way & Old Newport Blvd (W)

HCM 6th TWSC
Synchro 11 Report

Intersection												
Int Delay, s/veh	3.6											
Movement	EBL	EBT	EBR	WBL	WBT	WBR	NBL	NBT	NBR	SBL	SBT	SBR
Lane Configurations		↕			↕			↕			↕	
Traffic Vol, veh/h	13	173	23	41	125	37	22	2	48	38	4	15
Future Vol, veh/h	13	173	23	41	125	37	22	2	48	38	4	15
Conflicting Peds, #/hr	0	0	0	0	0	0	0	0	0	0	0	0
Sign Control	Free	Free	Free	Free	Free	Free	Stop	Stop	Stop	Stop	Stop	Stop
RT Channelized	-	-	None	-	-	None	-	-	None	-	-	None
Storage Length	-	-	-	-	-	-	-	-	-	-	-	-
Veh in Median Storage, #	-	0	-	-	0	-	-	0	-	-	0	-
Grade, %	-	0	-	-	0	-	-	0	-	-	0	-
Peak Hour Factor	95	95	95	95	95	95	95	95	95	95	95	95
Heavy Vehicles, %	2	2	2	2	2	2	2	2	2	2	2	2
Mvmt Flow	14	182	24	43	132	39	23	2	51	40	4	16

Major/Minor	Major1			Major2			Minor1			Minor2		
Conflicting Flow All	171	0	0	206	0	0	470	479	194	487	472	152
Stage 1	-	-	-	-	-	-	222	222	-	238	238	-
Stage 2	-	-	-	-	-	-	248	257	-	249	234	-
Critical Hdwy	4.12	-	-	4.12	-	-	7.12	6.52	6.22	7.12	6.52	6.22
Critical Hdwy Stg 1	-	-	-	-	-	-	6.12	5.52	-	6.12	5.52	-
Critical Hdwy Stg 2	-	-	-	-	-	-	6.12	5.52	-	6.12	5.52	-
Follow-up Hdwy	2.218	-	-	2.218	-	-	3.518	4.018	3.318	3.518	4.018	3.318
Pot Cap-1 Maneuver	1406	-	-	1365	-	-	504	486	847	491	490	894
Stage 1	-	-	-	-	-	-	780	720	-	765	708	-
Stage 2	-	-	-	-	-	-	756	695	-	755	711	-
Platoon blocked, %	-	-	-	-	-	-	-	-	-	-	-	-
Mov Cap-1 Maneuver	1406	-	-	1365	-	-	475	464	847	444	467	894
Mov Cap-2 Maneuver	-	-	-	-	-	-	475	464	-	444	467	-
Stage 1	-	-	-	-	-	-	771	712	-	757	683	-
Stage 2	-	-	-	-	-	-	712	671	-	700	703	-

Approach	EB			WB			NB			SB		
HCM Control Delay, s	0.5			1.6			11			12.9		
HCM LOS							B			B		

Minor Lane/Major Mvmt	NBLn1	EBL	EBT	EBR	WBL	WBT	WBR	SBLn1
Capacity (veh/h)	671	1406	-	-	1365	-	-	514
HCM Lane V/C Ratio	0.113	0.01	-	-	0.032	-	-	0.117
HCM Control Delay (s)	11	7.6	0	-	7.7	0	-	12.9
HCM Lane LOS	B	A	A	-	A	A	-	B
HCM 95th %tile Q(veh)	0.4	0	-	-	0.1	-	-	0.4

Cumulative Conditions with Project - Mid-Day
7: Newport Blvd & Industrial Way

Lanes, Volumes, Timings
Synchro 11 Report

Lane Group	EBL	EBT	EBR	WBL	WBT	WBR	NBL	NBT	NBR	SBL	SBT	SBR
Lane Configurations												
Traffic Volume (vph)	75	53	127	10	74	98	43	1662	14	112	1683	67
Future Volume (vph)	75	53	127	10	74	98	43	1662	14	112	1683	67
Ideal Flow (vphpl)	1900	1900	1900	1900	1900	1900	1900	1900	1900	1900	1900	1900
Storage Length (ft)	0		0	0		0	90		0	95		0
Storage Lanes	0		1	1		1	1		0	1		0
Taper Length (ft)	25			25			25			25		
Satd. Flow (prot)	0	1811	1583	1770	1863	1583	1770	5080	0	1770	5055	0
Flt Permitted		0.730		0.462			0.950			0.950		
Satd. Flow (perm)	0	1360	1583	861	1863	1583	1770	5080	0	1770	5055	0
Right Turn on Red			Yes			Yes			Yes			Yes
Satd. Flow (RTOR)			132			102		1				7
Link Speed (mph)		30			30			50				50
Link Distance (ft)		175			191			846				1146
Travel Time (s)		4.0			4.3			11.5				15.6
Peak Hour Factor	0.96	0.96	0.96	0.96	0.96	0.96	0.96	0.96	0.96	0.96	0.96	0.96
Shared Lane Traffic (%)												
Lane Group Flow (vph)	0	133	132	10	77	102	45	1746	0	117	1823	0
Turn Type	Perm	NA	Perm	Perm	NA	Perm	Prot	NA		Prot	NA	
Protected Phases		4			8		5	2		1	6	
Permitted Phases	4		4	8		8						
Total Split (s)	40.6	40.6	40.6	40.6	40.6	40.6	15.2	76.4		26.2	76.4	
Total Lost Time (s)		4.6	4.6	4.6	4.6	4.6	4.2	6.4		4.2	6.4	
Act Effct Green (s)		17.4	17.4	17.4	17.4	17.4	9.4	96.9		13.6	103.8	
Actuated g/C Ratio		0.12	0.12	0.12	0.12	0.12	0.07	0.68		0.09	0.72	
v/c Ratio		0.81	0.43	0.10	0.34	0.36	0.39	0.51		0.70	0.50	
Control Delay		93.2	12.5	54.6	60.0	13.0	74.0	13.1		83.5	10.1	
Queue Delay		0.0	0.0	0.0	0.0	0.0	0.0	0.0		0.0	0.0	
Total Delay		93.2	12.5	54.6	60.0	13.0	74.0	13.1		83.5	10.1	
LOS		F	B	D	E	B	E	B		F	B	
Approach Delay		53.0			34.3			14.6			14.6	
Approach LOS		D			C			B			B	

Intersection Summary

Area Type: Other
 Cycle Length: 143.2
 Actuated Cycle Length: 143.2
 Offset: 90 (63%), Referenced to phase 2:NBT and 6:SBT, Start of Green
 Control Type: Actuated-Coordinated
 Maximum v/c Ratio: 0.81
 Intersection Signal Delay: 17.9 Intersection LOS: B
 Intersection Capacity Utilization 67.8% ICU Level of Service C
 Analysis Period (min) 15

Splits and Phases: 7: Newport Blvd & Industrial Way



**CUMULATIVE CONDITIONS
WITH PROJECT
PM PEAK HOUR**

Cumulative Conditions with Project - PM Peak Hour

Lanes, Volumes, Timings

1: Superior Ave & 17th St

Synchro 11 Report

Lane Group	EBL	EBT	EBR	WBL	WBT	WBR	NBL	NBT	NBR	SBL	SBT	SBR
Lane Configurations												
Traffic Volume (vph)	35	518	69	239	433	66	110	156	556	73	307	111
Future Volume (vph)	35	518	69	239	433	66	110	156	556	73	307	111
Ideal Flow (vphpl)	1900	1900	1900	1900	1900	1900	1900	1900	1900	1900	1900	1900
Storage Length (ft)	100		250	0		0	80		0	90		0
Storage Lanes	1		1	1		0	1		1	1		0
Taper Length (ft)	25			25			25			25		
Satd. Flow (prot)	1770	3539	1583	1770	3468	0	1770	1617	1504	1770	3398	0
Flt Permitted	0.950			0.298			0.368			0.217		
Satd. Flow (perm)	1770	3539	1583	555	3468	0	685	1617	1504	404	3398	0
Right Turn on Red			Yes			Yes			Yes			Yes
Satd. Flow (RTOR)			200		23			78	374		59	
Link Speed (mph)		35			30			35			35	
Link Distance (ft)		556			357			606			247	
Travel Time (s)		10.8			8.1			11.8			4.8	
Peak Hour Factor	0.92	0.92	0.92	0.92	0.92	0.92	0.92	0.92	0.92	0.92	0.92	0.92
Shared Lane Traffic (%)									38%			
Lane Group Flow (vph)	38	563	75	260	543	0	120	400	374	79	455	0
Turn Type	Prot	NA	Perm	pm+pt	NA		pm+pt	NA	Perm	pm+pt	NA	
Protected Phases	1	6		5	2		3	8		7	4	
Permitted Phases			6	2			8		8	4		
Total Split (s)	12.0	24.0	24.0	21.0	33.0		12.0	23.0	23.0	12.0	23.0	
Total Lost Time (s)	4.2	5.1	5.1	4.2	5.1		4.2	5.1	5.1	4.2	5.1	
Act Effct Green (s)	6.0	26.8	26.8	43.1	35.7		25.3	18.6	18.6	24.9	18.4	
Actuated g/C Ratio	0.08	0.34	0.34	0.54	0.45		0.32	0.23	0.23	0.31	0.23	
v/c Ratio	0.29	0.48	0.11	0.55	0.35		0.39	0.92	0.59	0.33	0.55	
Control Delay	40.1	24.7	0.3	15.8	16.8		20.6	53.7	7.4	19.9	26.5	
Queue Delay	0.0	0.0	0.0	0.0	0.0		0.0	0.0	0.0	0.0	0.0	
Total Delay	40.1	24.7	0.3	15.8	16.8		20.6	53.7	7.4	19.9	26.5	
LOS	D	C	A	B	B		C	D	A	B	C	
Approach Delay		22.8			16.5			29.9			25.5	
Approach LOS		C			B			C			C	

Intersection Summary

Area Type: Other
 Cycle Length: 80
 Actuated Cycle Length: 80
 Offset: 28 (35%), Referenced to phase 2:WBTL and 6:EBT, Start of Green
 Control Type: Actuated-Coordinated
 Maximum v/c Ratio: 0.92
 Intersection Signal Delay: 23.7
 Intersection LOS: C
 Intersection Capacity Utilization 66.8%
 ICU Level of Service C
 Analysis Period (min) 15

Splits and Phases: 1: Superior Ave & 17th St

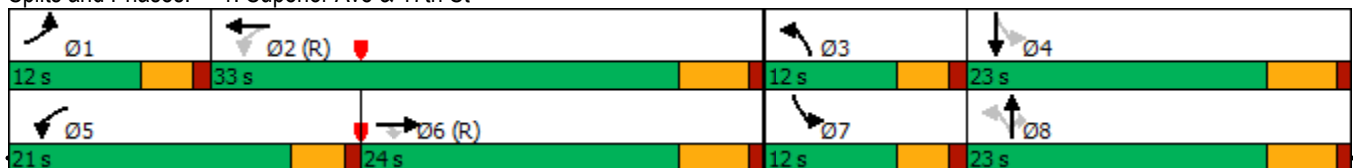

Intersection						
Int Delay, s/veh	1					
Movement	WBL	WBR	NBT	NBR	SBL	SBT
Lane Configurations	↔		↕↔		↔	↕↕
Traffic Vol, veh/h	23	44	760	16	30	585
Future Vol, veh/h	23	44	760	16	30	585
Conflicting Peds, #/hr	0	0	0	0	0	0
Sign Control	Stop	Stop	Free	Free	Free	Free
RT Channelized	-	None	-	None	-	None
Storage Length	0	-	-	-	65	-
Veh in Median Storage, #	0	-	0	-	-	0
Grade, %	0	-	0	-	-	0
Peak Hour Factor	84	84	84	84	84	84
Heavy Vehicles, %	2	2	2	2	2	2
Mvmt Flow	27	52	905	19	36	696

Major/Minor	Minor1	Major1	Major2		
Conflicting Flow All	1335	462	0	0	924
Stage 1	915	-	-	-	-
Stage 2	420	-	-	-	-
Critical Hdwy	6.84	6.94	-	-	4.14
Critical Hdwy Stg 1	5.84	-	-	-	-
Critical Hdwy Stg 2	5.84	-	-	-	-
Follow-up Hdwy	3.52	3.32	-	-	2.22
Pot Cap-1 Maneuver	145	547	-	-	735
Stage 1	351	-	-	-	-
Stage 2	631	-	-	-	-
Platoon blocked, %			-	-	-
Mov Cap-1 Maneuver	138	547	-	-	735
Mov Cap-2 Maneuver	259	-	-	-	-
Stage 1	351	-	-	-	-
Stage 2	600	-	-	-	-

Approach	WB	NB	SB
HCM Control Delay, s	16.4	0	0.5
HCM LOS	C		

Minor Lane/Major Mvmt	NBT	NBRWBLn1	SBL	SBT
Capacity (veh/h)	-	-	396	735
HCM Lane V/C Ratio	-	-	0.201	0.049
HCM Control Delay (s)	-	-	16.4	10.1
HCM Lane LOS	-	-	C	B
HCM 95th %tile Q(veh)	-	-	0.7	0.2

Cumulative Conditions With Project - PM Peak Hour
 3: Old Newport Blvd (W) & E 16th St

HCM 6th TWSC
 Synchro 11 Report

Intersection												
Int Delay, s/veh	4.4											
Movement	EBL	EBT	EBR	WBL	WBT	WBR	NBL	NBT	NBR	SBL	SBT	SBR
Lane Configurations		↻			↻			↻			↻	
Traffic Vol, veh/h	1	44	6	50	65	3	7	0	45	8	1	11
Future Vol, veh/h	1	44	6	50	65	3	7	0	45	8	1	11
Conflicting Peds, #/hr	0	0	0	0	0	0	0	0	0	0	0	0
Sign Control	Free	Free	Free	Free	Free	Free	Stop	Stop	Stop	Stop	Stop	Stop
RT Channelized	-	-	None	-	-	None	-	-	None	-	-	None
Storage Length	-	-	-	-	-	-	-	-	-	-	-	-
Veh in Median Storage, #	-	0	-	-	0	-	-	0	-	-	0	-
Grade, %	-	0	-	-	0	-	-	0	-	-	0	-
Peak Hour Factor	72	72	72	72	72	72	72	72	72	72	72	72
Heavy Vehicles, %	2	2	2	2	2	2	2	2	2	2	2	2
Mvmt Flow	1	61	8	69	90	4	10	0	63	11	1	15

Major/Minor	Major1			Major2			Minor1			Minor2		
Conflicting Flow All	94	0	0	69	0	0	305	299	65	329	301	92
Stage 1	-	-	-	-	-	-	67	67	-	230	230	-
Stage 2	-	-	-	-	-	-	238	232	-	99	71	-
Critical Hdwy	4.12	-	-	4.12	-	-	7.12	6.52	6.22	7.12	6.52	6.22
Critical Hdwy Stg 1	-	-	-	-	-	-	6.12	5.52	-	6.12	5.52	-
Critical Hdwy Stg 2	-	-	-	-	-	-	6.12	5.52	-	6.12	5.52	-
Follow-up Hdwy	2.218	-	-	2.218	-	-	3.518	4.018	3.318	3.518	4.018	3.318
Pot Cap-1 Maneuver	1500	-	-	1532	-	-	647	613	999	624	612	965
Stage 1	-	-	-	-	-	-	943	839	-	773	714	-
Stage 2	-	-	-	-	-	-	765	713	-	907	836	-
Platoon blocked, %	-	-	-	-	-	-	-	-	-	-	-	-
Mov Cap-1 Maneuver	1500	-	-	1532	-	-	612	583	999	563	582	965
Mov Cap-2 Maneuver	-	-	-	-	-	-	612	583	-	563	582	-
Stage 1	-	-	-	-	-	-	942	838	-	772	680	-
Stage 2	-	-	-	-	-	-	715	679	-	849	835	-

Approach	EB			WB			NB			SB		
HCM Control Delay, s	0.1			3.2			9.2			10.1		
HCM LOS							A			B		

Minor Lane/Major Mvmt	NBLn1	EBL	EBT	EBR	WBL	WBT	WBR	SBLn1
Capacity (veh/h)	921	1500	-	-	1532	-	-	732
HCM Lane V/C Ratio	0.078	0.001	-	-	0.045	-	-	0.038
HCM Control Delay (s)	9.2	7.4	-	-	7.5	0	-	10.1
HCM Lane LOS	A	A	-	-	A	A	-	B
HCM 95th %tile Q(veh)	0.3	0	-	-	0.1	-	-	0.1

Cumulative Conditions with Project - PM Peak Hour
4: Newport Blvd & E 16th St

Lanes, Volumes, Timings
Synchro 11 Report

Lane Group	EBL	EBT	EBR	WBL	WBT	WBR	NBL	NBT	NBR	SBL	SBT	SBR
Lane Configurations												
Traffic Volume (vph)	31	37	34	86	52	54	32	1711	75	49	1729	29
Future Volume (vph)	31	37	34	86	52	54	32	1711	75	49	1729	29
Ideal Flow (vphpl)	1900	1900	1900	1900	1900	1900	1900	1900	1900	1900	1900	1900
Storage Length (ft)	0		0	0		0	95		0	85		55
Storage Lanes	0		0	0		0	1		0	1		1
Taper Length (ft)	25			25			25			25		
Satd. Flow (prot)	0	1752	0	0	1753	0	1770	5055	0	1770	5085	1583
Flt Permitted		0.803			0.758		0.950			0.950		
Satd. Flow (perm)	0	1428	0	0	1358	0	1770	5055	0	1770	5085	1583
Right Turn on Red			Yes			Yes			No			Yes
Satd. Flow (RTOR)		18			14							57
Link Speed (mph)		25			25			50				50
Link Distance (ft)		160			479			1146				979
Travel Time (s)		4.4			13.1			15.6				13.4
Peak Hour Factor	0.89	0.89	0.89	0.89	0.89	0.89	1.00	0.89	0.89	0.89	0.89	0.89
Shared Lane Traffic (%)												
Lane Group Flow (vph)	0	115	0	0	216	0	32	2006	0	55	1943	33
Turn Type	Perm	NA		Perm	NA		Prot	NA		Prot	NA	Perm
Protected Phases		4			8		5	2		1	6	
Permitted Phases	4			8								6
Total Split (s)	45.0	45.0		45.0	45.0		15.2	75.7		18.2	75.7	75.7
Total Lost Time (s)		6.0			6.0		4.2	5.7		4.2	5.7	5.7
Act Effct Green (s)		24.8			24.8		9.2	90.9		9.9	94.4	94.4
Actuated g/C Ratio		0.18			0.18		0.07	0.65		0.07	0.68	0.68
v/c Ratio		0.43			0.85		0.28	0.61		0.44	0.56	0.03
Control Delay		45.8			79.5		68.0	16.6		72.4	14.3	1.0
Queue Delay		0.0			0.0		0.0	0.0		0.0	0.0	0.0
Total Delay		45.8			79.5		68.0	16.6		72.4	14.3	1.0
LOS		D			E		E	B		E	B	A
Approach Delay		45.8			79.5			17.4				15.7
Approach LOS		D			E			B				B

Intersection Summary

Area Type: Other
 Cycle Length: 138.9
 Actuated Cycle Length: 138.9
 Offset: 98 (71%), Referenced to phase 2:NBT and 6:SBT, Start of Green
 Control Type: Actuated-Coordinated
 Maximum v/c Ratio: 0.85
 Intersection Signal Delay: 20.4
 Intersection LOS: C
 Intersection Capacity Utilization 67.4%
 ICU Level of Service C
 Analysis Period (min) 15

Splits and Phases: 4: Newport Blvd & E 16th St



Cumulative Conditions with Project - PM Peak Hour
 5: Superior Ave & W 16th St/Industrial Way

Lanes, Volumes, Timings
 Synchro 11 Report

Lane Group	EBL	EBT	EBR	WBL	WBT	WBR	NBL	NBT	NBR	SBL	SBT	SBR
Lane Configurations												
Traffic Volume (vph)	81	88	67	26	79	21	44	604	60	26	482	55
Future Volume (vph)	81	88	67	26	79	21	44	604	60	26	482	55
Ideal Flow (vphpl)	1900	1900	1900	1900	1900	1900	1900	1900	1900	1900	1900	1900
Storage Length (ft)	0		0	0		0	100		110	100		0
Storage Lanes	1		0	0		0	1		1	1		0
Taper Length (ft)	25			25			25			25		
Satd. Flow (prot)	1770	1742	0	0	1802	0	1770	3539	1583	1770	3486	0
Flt Permitted	0.950				0.990		0.277			0.223		
Satd. Flow (perm)	1770	1742	0	0	1802	0	516	3539	1583	415	3486	0
Right Turn on Red			Yes			Yes			Yes			No
Satd. Flow (RTOR)		39			8				64			
Link Speed (mph)		30			30			40			35	
Link Distance (ft)		216			687			694			1138	
Travel Time (s)		4.9			15.6			11.8			22.2	
Peak Hour Factor	0.82	0.82	0.82	0.82	0.82	0.82	0.82	0.82	0.82	0.82	0.82	0.82
Shared Lane Traffic (%)												
Lane Group Flow (vph)	99	189	0	0	154	0	54	737	73	32	655	0
Turn Type	Split	NA		Split	NA		Perm	NA	Perm	Perm	NA	
Protected Phases	6	6		2	2			3			3	
Permitted Phases							3		3	3		
Total Split (s)	56.1	56.1		35.1	35.1		30.9	30.9	30.9	30.9	30.9	
Total Lost Time (s)	5.1	5.1			5.1		5.9	5.9	5.9	5.9	5.9	
Act Effct Green (s)	11.6	11.6			30.0		25.0	25.0	25.0	25.0	25.0	
Actuated g/C Ratio	0.14	0.14			0.36		0.30	0.30	0.30	0.30	0.30	
v/c Ratio	0.40	0.68			0.23		0.35	0.69	0.14	0.26	0.62	
Control Delay	37.0	39.5			19.4		31.6	30.0	8.5	29.8	28.5	
Queue Delay	0.0	0.0			0.0		0.0	0.0	0.0	0.0	0.0	
Total Delay	37.0	39.5			19.4		31.6	30.0	8.5	29.8	28.5	
LOS	D	D			B		C	C	A	C	C	
Approach Delay		38.6			19.4			28.3			28.5	
Approach LOS		D			B			C			C	

Intersection Summary

Area Type: Other
 Cycle Length: 122.1
 Actuated Cycle Length: 82.8
 Control Type: Actuated-Uncoordinated
 Maximum v/c Ratio: 0.69
 Intersection Signal Delay: 29.2
 Intersection LOS: C
 Intersection Capacity Utilization 54.0%
 ICU Level of Service A
 Analysis Period (min) 15

Splits and Phases: 5: Superior Ave & W 16th St/Industrial Way



Cumulative Conditions With Project - PM Peak Hour
6: Industrial Way & Old Newport Blvd (W)

HCM 6th TWSC
Synchro 11 Report

Intersection												
Int Delay, s/veh	2.6											
Movement	EBL	EBT	EBR	WBL	WBT	WBR	NBL	NBT	NBR	SBL	SBT	SBR
Lane Configurations		↕			↕			↕			↕	
Traffic Vol, veh/h	6	161	9	16	108	42	7	0	14	40	0	17
Future Vol, veh/h	6	161	9	16	108	42	7	0	14	40	0	17
Conflicting Peds, #/hr	0	0	0	0	0	0	0	0	0	0	0	0
Sign Control	Free	Free	Free	Free	Free	Free	Stop	Stop	Stop	Stop	Stop	Stop
RT Channelized	-	-	None	-	-	None	-	-	None	-	-	None
Storage Length	-	-	-	-	-	-	-	-	-	-	-	-
Veh in Median Storage, #	-	0	-	-	0	-	-	0	-	-	0	-
Grade, %	-	0	-	-	0	-	-	0	-	-	0	-
Peak Hour Factor	76	76	76	76	76	76	76	76	76	76	76	76
Heavy Vehicles, %	2	2	2	2	2	2	2	2	2	2	2	2
Mvmt Flow	8	212	12	21	142	55	9	0	18	53	0	22

Major/Minor	Major1			Major2			Minor1			Minor2		
Conflicting Flow All	197	0	0	224	0	0	457	473	218	455	452	170
Stage 1	-	-	-	-	-	-	234	234	-	212	212	-
Stage 2	-	-	-	-	-	-	223	239	-	243	240	-
Critical Hdwy	4.12	-	-	4.12	-	-	7.12	6.52	6.22	7.12	6.52	6.22
Critical Hdwy Stg 1	-	-	-	-	-	-	6.12	5.52	-	6.12	5.52	-
Critical Hdwy Stg 2	-	-	-	-	-	-	6.12	5.52	-	6.12	5.52	-
Follow-up Hdwy	2.218	-	-	2.218	-	-	3.518	4.018	3.318	3.518	4.018	3.318
Pot Cap-1 Maneuver	1376	-	-	1345	-	-	514	490	822	515	503	874
Stage 1	-	-	-	-	-	-	769	711	-	790	727	-
Stage 2	-	-	-	-	-	-	780	708	-	761	707	-
Platoon blocked, %	-	-	-	-	-	-	-	-	-	-	-	-
Mov Cap-1 Maneuver	1376	-	-	1345	-	-	491	478	822	494	490	874
Mov Cap-2 Maneuver	-	-	-	-	-	-	491	478	-	494	490	-
Stage 1	-	-	-	-	-	-	764	706	-	784	714	-
Stage 2	-	-	-	-	-	-	746	695	-	739	702	-

Approach	EB			WB			NB			SB		
HCM Control Delay, s	0.3			0.7			10.6			12.3		
HCM LOS							B			B		

Minor Lane/Major Mvmt	NBLn1	EBL	EBT	EBR	WBL	WBT	WBR	SBLn1
Capacity (veh/h)	671	1376	-	-	1345	-	-	568
HCM Lane V/C Ratio	0.041	0.006	-	-	0.016	-	-	0.132
HCM Control Delay (s)	10.6	7.6	0	-	7.7	0	-	12.3
HCM Lane LOS	B	A	A	-	A	A	-	B
HCM 95th %tile Q(veh)	0.1	0	-	-	0	-	-	0.5

Cumulative Conditions with Project - PM Peak Hour
7: Newport Blvd & Industrial Way

Lanes, Volumes, Timings
Synchro 11 Report

Lane Group	EBL	EBT	EBR	WBL	WBT	WBR	NBL	NBT	NBR	SBL	SBT	SBR
Lane Configurations												
Traffic Volume (vph)	72	62	77	12	74	110	43	1621	8	63	1739	58
Future Volume (vph)	72	62	77	12	74	110	43	1621	8	63	1739	58
Ideal Flow (vphpl)	1900	1900	1900	1900	1900	1900	1900	1900	1900	1900	1900	1900
Storage Length (ft)	0		0	0		0	90		0	95		0
Storage Lanes	0		1	1		1	1		0	1		0
Taper Length (ft)	25			25			25			25		
Satd. Flow (prot)	0	1814	1583	1770	1863	1583	1770	5080	0	1770	5060	0
Flt Permitted		0.724		0.422			0.950			0.950		
Satd. Flow (perm)	0	1349	1583	786	1863	1583	1770	5080	0	1770	5060	0
Right Turn on Red			Yes			Yes			Yes			Yes
Satd. Flow (RTOR)			90			126		1				6
Link Speed (mph)		30			30			50				50
Link Distance (ft)		175			191			846				1146
Travel Time (s)		4.0			4.3			11.5				15.6
Peak Hour Factor	0.87	0.87	0.87	0.87	0.87	0.87	0.87	0.87	0.87	0.87	0.87	0.87
Shared Lane Traffic (%)												
Lane Group Flow (vph)	0	154	89	14	85	126	49	1872	0	72	2066	0
Turn Type	Perm	NA	Perm	Perm	NA	Perm	Prot	NA		Prot	NA	
Protected Phases		4			8		5	2		1	6	
Permitted Phases	4		4	8		8						
Total Split (s)	40.6	40.6	40.6	40.6	40.6	40.6	14.2	76.4		26.2	76.4	
Total Lost Time (s)		4.6	4.6	4.6	4.6	4.6	4.2	6.4		4.2	6.4	
Act Effct Green (s)		19.4	19.4	19.4	19.4	19.4	9.6	100.6		10.7	101.7	
Actuated g/C Ratio		0.14	0.14	0.14	0.14	0.14	0.07	0.70		0.07	0.71	
v/c Ratio		0.85	0.30	0.13	0.34	0.39	0.42	0.52		0.55	0.57	
Control Delay		95.2	12.1	54.1	58.0	11.6	74.8	12.2		79.1	12.3	
Queue Delay		0.0	0.0	0.0	0.0	0.0	0.0	0.0		0.0	0.0	
Total Delay		95.2	12.1	54.1	58.0	11.6	74.8	12.2		79.1	12.3	
LOS		F	B	D	E	B	E	B		E	B	
Approach Delay		64.8			31.8			13.8			14.6	
Approach LOS		E			C			B			B	

Intersection Summary

Area Type: Other
 Cycle Length: 143.2
 Actuated Cycle Length: 143.2
 Offset: 88 (61%), Referenced to phase 2:NBT and 6:SBT, Start of Green
 Control Type: Actuated-Coordinated
 Maximum v/c Ratio: 0.85
 Intersection Signal Delay: 17.8 Intersection LOS: B
 Intersection Capacity Utilization 69.0% ICU Level of Service C
 Analysis Period (min) 15

Splits and Phases: 7: Newport Blvd & Industrial Way



**CUMULATIVE CONDITIONS
WITH PROJECT
MID-DAY (SATURDAY)**

Cumulative Conditions with Project - Mid-Day (Saturday)

Lanes, Volumes, Timings

1: Superior Ave & 17th St

Synchro 11 Report

Lane Group	EBL	EBT	EBR	WBL	WBT	WBR	NBL	NBT	NBR	SBL	SBT	SBR
Lane Configurations												
Traffic Volume (vph)	27	519	64	222	430	85	80	121	444	120	197	121
Future Volume (vph)	27	519	64	222	430	85	80	121	444	120	197	121
Ideal Flow (vphpl)	1900	1900	1900	1900	1900	1900	1900	1900	1900	1900	1900	1900
Storage Length (ft)	100		250	0		0	80		0	90		0
Storage Lanes	1		1	1		0	1		1	1		0
Taper Length (ft)	25			25			25			25		
Satd. Flow (prot)	1770	3539	1583	1770	3451	0	1770	1616	1504	1770	3337	0
Flt Permitted	0.950			0.319			0.496			0.284		
Satd. Flow (perm)	1770	3539	1583	594	3451	0	924	1616	1504	529	3337	0
Right Turn on Red			Yes			Yes			Yes			Yes
Satd. Flow (RTOR)			214		33			85	296		130	
Link Speed (mph)		35			30			35			35	
Link Distance (ft)		556			357			606			247	
Travel Time (s)		10.8			8.1			11.8			4.8	
Peak Hour Factor	0.93	0.93	0.93	0.93	0.93	0.93	0.93	0.93	0.93	0.93	0.93	0.93
Shared Lane Traffic (%)									38%			
Lane Group Flow (vph)	29	558	69	239	553	0	86	311	296	129	342	0
Turn Type	Prot	NA	Perm	pm+pt	NA		pm+pt	NA	Perm	pm+pt	NA	
Protected Phases	1	6		5	2		3	8		7	4	
Permitted Phases			6	2			8		8	4		
Total Split (s)	12.0	22.0	22.0	20.0	30.0		12.0	21.0	21.0	12.0	21.0	
Total Lost Time (s)	4.2	5.1	5.1	4.2	5.1		4.2	5.1	5.1	4.2	5.1	
Act Effct Green (s)	5.7	27.4	27.4	42.5	37.3		20.3	13.7	13.7	21.1	14.1	
Actuated g/C Ratio	0.08	0.37	0.37	0.57	0.50		0.27	0.18	0.18	0.28	0.19	
v/c Ratio	0.22	0.43	0.10	0.48	0.32		0.26	0.85	0.57	0.49	0.47	
Control Delay	36.1	22.0	0.3	13.3	13.9		17.9	43.6	8.4	23.1	18.1	
Queue Delay	0.0	0.0	0.0	0.0	0.0		0.0	0.0	0.0	0.0	0.0	
Total Delay	36.1	22.0	0.3	13.3	13.9		17.9	43.6	8.4	23.1	18.1	
LOS	D	C	A	B	B		B	D	A	C	B	
Approach Delay		20.4			13.7			25.4			19.5	
Approach LOS		C			B			C			B	

Intersection Summary

Area Type: Other
 Cycle Length: 75
 Actuated Cycle Length: 75
 Offset: 9.6 (13%), Referenced to phase 2:WBTL and 6:EBT, Start of Green
 Control Type: Actuated-Coordinated
 Maximum v/c Ratio: 0.85
 Intersection Signal Delay: 19.5
 Intersection LOS: B
 Intersection Capacity Utilization 64.2%
 ICU Level of Service C
 Analysis Period (min) 15

Splits and Phases: 1: Superior Ave & 17th St

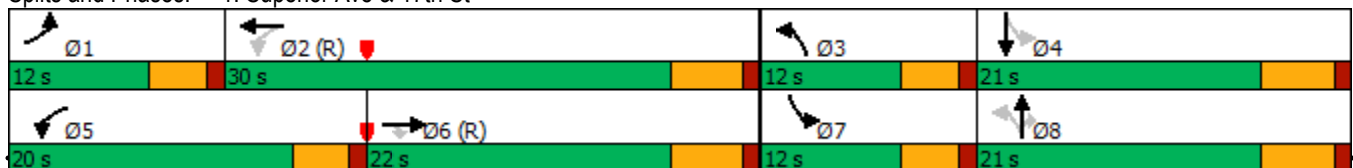

Intersection						
Int Delay, s/veh	1.1					
Movement	WBL	WBR	NBT	NBR	SBL	SBT
Lane Configurations	↔		↕↔		↕	↕↕
Traffic Vol, veh/h	32	47	600	19	35	465
Future Vol, veh/h	32	47	600	19	35	465
Conflicting Peds, #/hr	0	0	0	0	0	0
Sign Control	Stop	Stop	Free	Free	Free	Free
RT Channelized	-	None	-	None	-	None
Storage Length	0	-	-	-	65	-
Veh in Median Storage, #	0	-	0	-	-	0
Grade, %	0	-	0	-	-	0
Peak Hour Factor	92	100	92	92	92	92
Heavy Vehicles, %	2	2	2	2	2	2
Mvmt Flow	35	47	652	21	38	505

Major/Minor	Minor1	Major1	Major2		
Conflicting Flow All	992	337	0	0	673
Stage 1	663	-	-	-	-
Stage 2	329	-	-	-	-
Critical Hdwy	6.84	6.94	-	-	4.14
Critical Hdwy Stg 1	5.84	-	-	-	-
Critical Hdwy Stg 2	5.84	-	-	-	-
Follow-up Hdwy	3.52	3.32	-	-	2.22
Pot Cap-1 Maneuver	243	659	-	-	914
Stage 1	474	-	-	-	-
Stage 2	701	-	-	-	-
Platoon blocked, %			-	-	-
Mov Cap-1 Maneuver	233	659	-	-	914
Mov Cap-2 Maneuver	355	-	-	-	-
Stage 1	474	-	-	-	-
Stage 2	672	-	-	-	-

Approach	WB	NB	SB
HCM Control Delay, s	14	0	0.6
HCM LOS	B		

Minor Lane/Major Mvmt	NBT	NBRWBLn1	SBL	SBT
Capacity (veh/h)	-	-	483	914
HCM Lane V/C Ratio	-	-	0.169	0.042
HCM Control Delay (s)	-	-	14	9.1
HCM Lane LOS	-	-	B	A
HCM 95th %tile Q(veh)	-	-	0.6	0.1

Cumulative Conditions With Project - Mid-Day (Saturday)
 3: Old Newport Blvd (W) & E 16th St

HCM 6th TWSC
 Synchro 11 Report

Intersection												
Int Delay, s/veh	4.1											
Movement	EBL	EBT	EBR	WBL	WBT	WBR	NBL	NBT	NBR	SBL	SBT	SBR
Lane Configurations		↻			↻			↻			↻	
Traffic Vol, veh/h	3	42	11	54	74	8	7	0	55	9	0	3
Future Vol, veh/h	3	42	11	54	74	8	7	0	55	9	0	3
Conflicting Peds, #/hr	0	0	0	0	0	0	0	0	0	0	0	0
Sign Control	Free	Free	Free	Free	Free	Free	Stop	Stop	Stop	Stop	Stop	Stop
RT Channelized	-	-	None	-	-	None	-	-	None	-	-	None
Storage Length	-	-	-	-	-	-	-	-	-	-	-	-
Veh in Median Storage, #	-	0	-	-	0	-	-	0	-	-	0	-
Grade, %	-	0	-	-	0	-	-	0	-	-	0	-
Peak Hour Factor	94	94	94	94	94	94	94	94	94	94	94	94
Heavy Vehicles, %	2	2	2	2	2	2	2	2	2	2	2	2
Mvmt Flow	3	45	12	57	79	9	7	0	59	10	0	3

Major/Minor	Major1			Major2			Minor1			Minor2		
Conflicting Flow All	88	0	0	57	0	0	256	259	51	285	261	84
Stage 1	-	-	-	-	-	-	57	57	-	198	198	-
Stage 2	-	-	-	-	-	-	199	202	-	87	63	-
Critical Hdwy	4.12	-	-	4.12	-	-	7.12	6.52	6.22	7.12	6.52	6.22
Critical Hdwy Stg 1	-	-	-	-	-	-	6.12	5.52	-	6.12	5.52	-
Critical Hdwy Stg 2	-	-	-	-	-	-	6.12	5.52	-	6.12	5.52	-
Follow-up Hdwy	2.218	-	-	2.218	-	-	3.518	4.018	3.318	3.518	4.018	3.318
Pot Cap-1 Maneuver	1508	-	-	1547	-	-	697	645	1017	667	644	975
Stage 1	-	-	-	-	-	-	955	847	-	804	737	-
Stage 2	-	-	-	-	-	-	803	734	-	921	842	-
Platoon blocked, %	-	-	-	-	-	-	-	-	-	-	-	-
Mov Cap-1 Maneuver	1508	-	-	1547	-	-	673	619	1017	609	618	975
Mov Cap-2 Maneuver	-	-	-	-	-	-	673	619	-	609	618	-
Stage 1	-	-	-	-	-	-	953	845	-	802	708	-
Stage 2	-	-	-	-	-	-	769	705	-	866	840	-

Approach	EB			WB			NB			SB		
HCM Control Delay, s	0.4			2.9			9			10.5		
HCM LOS							A			B		

Minor Lane/Major Mvmt	NBLn1	EBL	EBT	EBR	WBL	WBT	WBR	SBLn1
Capacity (veh/h)	962	1508	-	-	1547	-	-	672
HCM Lane V/C Ratio	0.069	0.002	-	-	0.037	-	-	0.019
HCM Control Delay (s)	9	7.4	-	-	7.4	0	-	10.5
HCM Lane LOS	A	A	-	-	A	A	-	B
HCM 95th %tile Q(veh)	0.2	0	-	-	0.1	-	-	0.1

Cumulative Conditions with Project - Mid-Day (Saturday)

Lanes, Volumes, Timings

4: Newport Blvd & E 16th St

Synchro 11 Report

Lane Group	EBL	EBT	EBR	WBL	WBT	WBR	NBL	NBT	NBR	SBL	SBT	SBR
Lane Configurations												
Traffic Volume (vph)	36	34	31	81	52	82	32	1888	81	52	1983	31
Future Volume (vph)	36	34	31	81	52	82	32	1888	81	52	1983	31
Ideal Flow (vphpl)	1900	1900	1900	1900	1900	1900	1900	1900	1900	1900	1900	1900
Storage Length (ft)	0		0	0		0	95		0	85		55
Storage Lanes	0		0	0		0	1		0	1		1
Taper Length (ft)	25			25			25			25		
Satd. Flow (prot)	0	1754	0	0	1736	0	1770	5055	0	1770	5085	1583
Flt Permitted		0.734			0.801		0.950			0.950		
Satd. Flow (perm)	0	1310	0	0	1416	0	1770	5055	0	1770	5085	1583
Right Turn on Red			Yes			Yes			No			Yes
Satd. Flow (RTOR)		16			22							56
Link Speed (mph)		25			25			50			50	
Link Distance (ft)		160			479			1146			979	
Travel Time (s)		4.4			13.1			15.6			13.4	
Peak Hour Factor	0.92	0.92	0.92	0.92	0.92	0.92	0.92	0.92	0.92	0.92	0.92	0.92
Shared Lane Traffic (%)												
Lane Group Flow (vph)	0	110	0	0	234	0	35	2140	0	57	2155	34
Turn Type	Perm	NA		Perm	NA		Prot	NA		Prot	NA	Perm
Protected Phases		4			8		5	2		1	6	
Permitted Phases	4			8								6
Total Split (s)	45.0	45.0		45.0	45.0		18.2	75.7		19.2	75.7	75.7
Total Lost Time (s)		6.0			6.0		4.2	5.7		4.2	5.7	5.7
Act Effct Green (s)		25.4			25.4		9.2	91.2		10.0	92.0	92.0
Actuated g/C Ratio		0.18			0.18		0.07	0.65		0.07	0.66	0.66
v/c Ratio		0.44			0.85		0.30	0.65		0.45	0.64	0.03
Control Delay		47.1			76.1		69.3	17.9		73.5	17.1	1.3
Queue Delay		0.0			0.0		0.0	0.0		0.0	0.0	0.0
Total Delay		47.1			76.1		69.3	17.9		73.5	17.1	1.3
LOS		D			E		E	B		E	B	A
Approach Delay		47.1			76.1			18.7			18.3	
Approach LOS		D			E			B			B	

Intersection Summary

Area Type: Other
 Cycle Length: 139.9
 Actuated Cycle Length: 139.9
 Offset: 103 (74%), Referenced to phase 2:NBT and 6:SBT, Start of Green
 Control Type: Actuated-Coordinated
 Maximum v/c Ratio: 0.85
 Intersection Signal Delay: 22.0 Intersection LOS: C
 Intersection Capacity Utilization 69.3% ICU Level of Service C
 Analysis Period (min) 15

Splits and Phases: 4: Newport Blvd & E 16th St



Cumulative Conditions with Project - Mid-Day (Saturday)
 5: Superior Ave & W 16th St/Industrial Way

Lanes, Volumes, Timings
 Synchro 11 Report

Lane Group	EBL	EBT	EBR	WBL	WBT	WBR	NBL	NBT	NBR	SBL	SBT	SBR
Lane Configurations												
Traffic Volume (vph)	72	92	75	22	57	33	23	482	32	25	373	63
Future Volume (vph)	72	92	75	22	57	33	23	482	32	25	373	63
Ideal Flow (vphpl)	1900	1900	1900	1900	1900	1900	1900	1900	1900	1900	1900	1900
Storage Length (ft)	0		0	0		0	100		110	100		0
Storage Lanes	1		0	0		0	1		1	1		0
Taper Length (ft)	25			25			25			25		
Satd. Flow (prot)	1770	1738	0	0	1770	0	1770	3539	1583	1770	3461	0
Flt Permitted	0.950				0.990		0.431			0.391		
Satd. Flow (perm)	1770	1738	0	0	1770	0	803	3539	1583	728	3461	0
Right Turn on Red			Yes			Yes			Yes			No
Satd. Flow (RTOR)		41			16				64			
Link Speed (mph)		30			30			40			35	
Link Distance (ft)		216			687			694			1138	
Travel Time (s)		4.9			15.6			11.8			22.2	
Peak Hour Factor	0.95	0.95	0.95	0.95	0.95	0.95	0.95	0.95	0.95	0.95	0.95	0.95
Shared Lane Traffic (%)												
Lane Group Flow (vph)	76	176	0	0	118	0	24	507	34	26	459	0
Turn Type	Split	NA		Split	NA		Perm	NA	Perm	Perm	NA	
Protected Phases	6	6		2	2			3			3	
Permitted Phases							3		3	3		
Total Split (s)	56.1	56.1		35.1	35.1		30.9	30.9	30.9	30.9	30.9	
Total Lost Time (s)	5.1	5.1			5.1		5.9	5.9	5.9	5.9	5.9	
Act Effct Green (s)	10.8	10.8			30.0		25.0	25.0	25.0	25.0	25.0	
Actuated g/C Ratio	0.13	0.13			0.37		0.30	0.30	0.30	0.30	0.30	
v/c Ratio	0.33	0.67			0.18		0.10	0.47	0.06	0.12	0.43	
Control Delay	35.7	38.3			16.9		23.2	25.4	2.4	23.7	25.0	
Queue Delay	0.0	0.0			0.0		0.0	0.0	0.0	0.0	0.0	
Total Delay	35.7	38.3			16.9		23.2	25.4	2.4	23.7	25.0	
LOS	D	D			B		C	C	A	C	C	
Approach Delay		37.5			16.9			23.9			24.9	
Approach LOS		D			B			C			C	

Intersection Summary

Area Type: Other
 Cycle Length: 122.1
 Actuated Cycle Length: 82
 Control Type: Actuated-Uncoordinated
 Maximum v/c Ratio: 0.67
 Intersection Signal Delay: 26.1
 Intersection LOS: C
 Intersection Capacity Utilization 49.8%
 ICU Level of Service A
 Analysis Period (min) 15

Splits and Phases: 5: Superior Ave & W 16th St/Industrial Way



Cumulative Conditions With Project - Mid-Day (Saturday)
 6: Industrial Way & Old Newport Blvd (W)

HCM 6th TWSC
 Synchro 11 Report

Intersection												
Int Delay, s/veh	3.1											
Movement	EBL	EBT	EBR	WBL	WBT	WBR	NBL	NBT	NBR	SBL	SBT	SBR
Lane Configurations		↕			↕			↕			↕	
Traffic Vol, veh/h	8	129	16	24	81	42	13	0	21	38	0	17
Future Vol, veh/h	8	129	16	24	81	42	13	0	21	38	0	17
Conflicting Peds, #/hr	0	0	0	0	0	0	0	0	0	0	0	0
Sign Control	Free	Free	Free	Free	Free	Free	Stop	Stop	Stop	Stop	Stop	Stop
RT Channelized	-	-	None	-	-	None	-	-	None	-	-	None
Storage Length	-	-	-	-	-	-	-	-	-	-	-	-
Veh in Median Storage, #	-	0	-	-	0	-	-	0	-	-	0	-
Grade, %	-	0	-	-	0	-	-	0	-	-	0	-
Peak Hour Factor	89	89	89	89	89	89	89	89	89	89	89	89
Heavy Vehicles, %	2	2	2	2	2	2	2	2	2	2	2	2
Mvmt Flow	9	145	18	27	91	47	15	0	24	43	0	19

Major/Minor	Major1			Major2			Minor1			Minor2		
Conflicting Flow All	138	0	0	163	0	0	350	364	154	353	350	115
Stage 1	-	-	-	-	-	-	172	172	-	169	169	-
Stage 2	-	-	-	-	-	-	178	192	-	184	181	-
Critical Hdwy	4.12	-	-	4.12	-	-	7.12	6.52	6.22	7.12	6.52	6.22
Critical Hdwy Stg 1	-	-	-	-	-	-	6.12	5.52	-	6.12	5.52	-
Critical Hdwy Stg 2	-	-	-	-	-	-	6.12	5.52	-	6.12	5.52	-
Follow-up Hdwy	2.218	-	-	2.218	-	-	3.518	4.018	3.318	3.518	4.018	3.318
Pot Cap-1 Maneuver	1446	-	-	1416	-	-	605	564	892	602	574	937
Stage 1	-	-	-	-	-	-	830	756	-	833	759	-
Stage 2	-	-	-	-	-	-	824	742	-	818	750	-
Platoon blocked, %		-	-		-	-						
Mov Cap-1 Maneuver	1446	-	-	1416	-	-	580	548	892	574	558	937
Mov Cap-2 Maneuver	-	-	-	-	-	-	580	548	-	574	558	-
Stage 1	-	-	-	-	-	-	824	751	-	827	743	-
Stage 2	-	-	-	-	-	-	790	726	-	791	745	-

Approach	EB			WB			NB			SB		
HCM Control Delay, s	0.4			1.2			10.1			11.1		
HCM LOS							B			B		

Minor Lane/Major Mvmt	NBLn1	EBL	EBT	EBR	WBL	WBT	WBR	SBLn1
Capacity (veh/h)	740	1446	-	-	1416	-	-	652
HCM Lane V/C Ratio	0.052	0.006	-	-	0.019	-	-	0.095
HCM Control Delay (s)	10.1	7.5	0	-	7.6	0	-	11.1
HCM Lane LOS	B	A	A	-	A	A	-	B
HCM 95th %tile Q(veh)	0.2	0	-	-	0.1	-	-	0.3

Cumulative Conditions with Project - Mid-Day (Saturday)
7: Newport Blvd & Industrial Way

Lanes, Volumes, Timings
Synchro 11 Report

Lane Group	EBL	EBT	EBR	WBL	WBT	WBR	NBL	NBT	NBR	SBL	SBT	SBR
Lane Configurations												
Traffic Volume (vph)	49	58	82	11	46	65	42	1884	16	43	1997	53
Future Volume (vph)	49	58	82	11	46	65	42	1884	16	43	1997	53
Ideal Flow (vphpl)	1900	1900	1900	1900	1900	1900	1900	1900	1900	1900	1900	1900
Storage Length (ft)	0		0	0		0	90		0	95		0
Storage Lanes	0		1	1		1	1		0	1		0
Taper Length (ft)	25			25			25			25		
Satd. Flow (prot)	0	1822	1583	1770	1863	1583	1770	5080	0	1770	5065	0
Flt Permitted		0.829		0.520			0.950			0.950		
Satd. Flow (perm)	0	1544	1583	969	1863	1583	1770	5080	0	1770	5065	0
Right Turn on Red			Yes			Yes			Yes			Yes
Satd. Flow (RTOR)			94			94		1				4
Link Speed (mph)		30			30			50				50
Link Distance (ft)		175			191			846				1146
Travel Time (s)		4.0			4.3			11.5				15.6
Peak Hour Factor	0.96	0.96	0.96	0.96	0.96	0.96	0.96	0.96	0.96	0.96	0.96	0.96
Shared Lane Traffic (%)												
Lane Group Flow (vph)	0	111	85	11	48	68	44	1980	0	45	2135	0
Turn Type	Perm	NA	Perm	Perm	NA	Perm	Prot	NA		Prot	NA	
Protected Phases		4			8		5	2		1	6	
Permitted Phases	4		4	8		8						
Total Split (s)	40.6	40.6	40.6	40.6	40.6	40.6	15.2	76.4		20.2	76.4	
Total Lost Time (s)		4.6	4.6	4.6	4.6	4.6	4.2	6.4		4.2	6.4	
Act Effct Green (s)		14.4	14.4	14.4	14.4	14.4	9.3	100.9		9.4	100.9	
Actuated g/C Ratio		0.10	0.10	0.10	0.10	0.10	0.07	0.74		0.07	0.74	
v/c Ratio		0.69	0.34	0.11	0.25	0.27	0.37	0.53		0.37	0.57	
Control Delay		79.8	12.0	55.5	57.9	6.9	69.9	9.4		70.1	10.0	
Queue Delay		0.0	0.0	0.0	0.0	0.0	0.0	0.0		0.0	0.0	
Total Delay		79.8	12.0	55.5	57.9	6.9	69.9	9.4		70.1	10.0	
LOS		E	B	E	E	A	E	A		E	B	
Approach Delay		50.4			30.4			10.8			11.3	
Approach LOS		D			C			B			B	

Intersection Summary

Area Type: Other
 Cycle Length: 137.2
 Actuated Cycle Length: 137.2
 Offset: 102 (74%), Referenced to phase 2:NBT and 6:SBT, Start of Green
 Control Type: Actuated-Coordinated
 Maximum v/c Ratio: 0.69
 Intersection Signal Delay: 13.3 Intersection LOS: B
 Intersection Capacity Utilization 69.4% ICU Level of Service C
 Analysis Period (min) 15

Splits and Phases: 7: Newport Blvd & Industrial Way



Appendix D PARKING AND QUEUING SURVEY DATA SHEETS



Raising Canes's Queue/Parking Study

3150 Harbor Blvd., Costa Mesa

Thursday, 9 February 2023

Time	Queue	Parking	Time	Queue	Parking	Time	Queue	Parking
11:00	3	14	3:00	2	15	7:00	18	7
11:05	3		3:05	1				
11:10	2		3:10	7				
11:15	5		3:15	5				
11:20	8		3:20	3				
11:25	3		3:25	2				
11:30	3	15	3:30	4	12			
11:35	2		3:35	3				
11:40	2		3:40	5				
11:45	3		3:45	3				
11:50	4		3:50	13				
11:55	3		3:55	10				
12:00	6	14	4:00	8	10			
12:05	6		4:05	5				
12:10	4		4:10	9				
12:15	10		4:15	2				
12:20	5		4:20	3				
12:25	8		4:25	4				
12:30	9	23	4:30	9	8			
12:35	2		4:35	11				
12:40	6		4:40	12				
12:45	13		4:45	7				
12:50	3		4:50	5				
12:55	4		4:55	9				
1:00	3	19	5:00	5	7			
1:05	2		5:05	5				
1:10	2		5:10	5				
1:15	3		5:15	6				
1:20	1		5:20	6				
1:25	1		5:25	8				
1:30	2	19	5:30	9	8			
1:35	1		5:35	10				
1:40	3		5:40	8				
1:45	4		5:45	6				
1:50	1		5:50	4				
1:55	5		5:55	3				
2:00	10	14	6:00	7	9			
2:05	11		6:05	3				
2:10	3		6:10	1				
2:15	5		6:15	4				
2:20	8		6:20	7				
2:25	11		6:25	8				
2:30	3	13	6:30	13	5			
2:35	17		6:35	16				
2:40	7		6:40	18				
2:45	2		6:45	13				
2:50	5		6:50	14				
2:55	1		6:55	16	157-			

Raising Canes's Queue/Parking Study
 2249 N. Tustin St., Orange
 Thursday, 9 February 2023

Time	Queue	Parking	Time	Queue	Parking	Time	Queue	Parking
11:00	0	3	3:00	6	4	7:00	9	4
11:05	2		3:05	7				
11:10	5		3:10	6				
11:15	4		3:15	5				
11:20	3		3:20	3				
11:25	5		3:25	2				
11:30	4	2	3:30	6	7			
11:35	1		3:35	7				
11:40	1		3:40	7				
11:45	2		3:45	5				
11:50	5		3:50	8				
11:55	4		3:55	12				
12:00	4	6	4:00	7	6			
12:05	0		4:05	6				
12:10	7		4:10	5				
12:15	5		4:15	4				
12:20	7		4:20	5				
12:25	13		4:25	4				
12:30	8	4	4:30	1	4			
12:35	1		4:35	3				
12:40	2		4:40	6				
12:45	4		4:45	3				
12:50	6		4:50	0				
12:55	3		4:55	3				
1:00	2	4	5:00	3	5			
1:05	2		5:05	2				
1:10	3		5:10	5				
1:15	4		5:15	5				
1:20	3		5:20	10				
1:25	2		5:25	14				
1:30	4	7	5:30	9	5			
1:35	2		5:35	6				
1:40	1		5:40	2				
1:45	4		5:45	1				
1:50	2		5:50	1				
1:55	1		5:55	3				
2:00	0	7	6:00	7	5			
2:05	1		6:05	14				
2:10	5		6:10	15				
2:15	1		6:15	18				
2:20	1		6:20	12				
2:25	4		6:25	17				
2:30	1	3	6:30	10	4			
2:35	0		6:35	10				
2:40	4		6:40	14				
2:45	7		6:45	10				
2:50	9		6:50	15				
2:55	8		6:55	10				

Raising Canes's Queue/Parking Study

23971 El Toro Rd., Laguna Hills

Thursday, 9 February 2023

Time	Queue	Parking	Time	Queue	Parking	Time	Queue	Parking
11:00	5	14	3:00	8	23	7:00	9	21
11:05	7		3:05	7				
11:10	6		3:10	11				
11:15	6		3:15	11				
11:20	5		3:20	10				
11:25	4		3:25	9				
11:30	2	21	3:30	5	21			
11:35	5		3:35	5				
11:40	4		3:40	4				
11:45	7		3:45	5				
11:50	8		3:50	3				
11:55	9		3:55	3				
12:00	9	20	4:00	5	19			
12:05	7		4:05	5				
12:10	9		4:10	5				
12:15	10		4:15	5				
12:20	12		4:20	5				
12:25	6		4:25	4				
12:30	10	23	4:30	6	19			
12:35	8		4:35	5				
12:40	8		4:40	4				
12:45	8		4:45	4				
12:50	4		4:50	4				
12:55	3		4:55	3				
1:00	5	20	5:00	4	20			
1:05	5		5:05	4				
1:10	3		5:10	4				
1:15	1		5:15	4				
1:20	2		5:20	4				
1:25	2		5:25	5				
1:30	2	24	5:30	7	19			
1:35	2		5:35	3				
1:40	2		5:40	5				
1:45	1		5:45	4				
1:50	3		5:50	6				
1:55	5		5:55	7				
2:00	3	29	6:00	7	18			
2:05	2		6:05	3				
2:10	1		6:10	5				
2:15	1		6:15	4				
2:20	2		6:20	9				
2:25	0		6:25	6				
2:30	3	26	6:30	6	27			
2:35	3		6:35	7				
2:40	4		6:40	5				
2:45	6		6:45	7				
2:50	6		6:50	7				
2:55	8		6:55	7-159-				

Raising Canes's Queue/Parking Study

3150 Harbor Blvd., Costa Mesa

Saturday, 11 February 2023

Time	Queue	Parking	Time	Queue	Parking	Time	Queue	Parking
11:00	2	9	3:00	19	12	7:00	15	5
11:05	2		3:05	16				
11:10	1		3:10	20				
11:15	4		3:15	18				
11:20	2		3:20	18				
11:25	3		3:25	12				
11:30	4	13	3:30	8	13			
11:35	5		3:35	9				
11:40	5		3:40	13				
11:45	9		3:45	18				
11:50	12		3:50	13				
11:55	13		3:55	5				
12:00	8	14	4:00	4	14			
12:05	3		4:05	6				
12:10	1		4:10	7				
12:15	6		4:15	5				
12:20	7		4:20	8				
12:25	10		4:25	2				
12:30	13	17	4:30	0	9			
12:35	16		4:35	2				
12:40	16		4:40	2				
12:45	11		4:45	0				
12:50	14		4:50	2				
12:55	13		4:55	11				
1:00	13	15	5:00	6	11			
1:05	10		5:05	13				
1:10	9		5:10	14				
1:15	14		5:15	15				
1:20	20		5:20	18				
1:25	18		5:25	11				
1:30	14	14	5:30	14	10			
1:35	7		5:35	3				
1:40	8		5:40	8				
1:45	9		5:45	17				
1:50	11		5:50	13				
1:55	8		5:55	9				
2:00	12	14	6:00	13	10			
2:05	11		6:05	17				
2:10	12		6:10	16				
2:15	14		6:15	15				
2:20	16		6:20	14				
2:25	15		6:25	18				
2:30	15	15	6:30	20	8			
2:35	12		6:35	21				
2:40	14		6:40	19				
2:45	19		6:45	20				
2:50	18		6:50	21				
2:55	17		6:55	19	160-			

Raising Canes's Queue/Parking Study
 2249 N. Tustin St., Orange
 Saturday, 11 February 2023

Time	Queue	Parking	Time	Queue	Parking	Time	Queue	Parking
11:00	2	0	3:00	8	5	7:00	9	3
11:05	6		3:05	5				
11:10	5		3:10	1				
11:15	8		3:15	3				
11:20	3		3:20	1				
11:25	2		3:25	4				
11:30	3	2	3:30	6	6			
11:35	6		3:35	2				
11:40	6		3:40	2				
11:45	4		3:45	3				
11:50	5		3:50	2				
11:55	10		3:55	1				
12:00	13	7	4:00	0	3			
12:05	11		4:05	3				
12:10	8		4:10	6				
12:15	13		4:15	4				
12:20	7		4:20	1				
12:25	9		4:25	2				
12:30	8	8	4:30	2	4			
12:35	12		4:35	5				
12:40	13		4:40	7				
12:45	19		4:45	3				
12:50	11		4:50	0				
12:55	7		4:55	4				
1:00	4	4	5:00	3	5			
1:05	3		5:05	7				
1:10	5		5:10	8				
1:15	7		5:15	9				
1:20	9		5:20	7				
1:25	16		5:25	8				
1:30	14	6	5:30	9	6			
1:35	11		5:35	11				
1:40	12		5:40	11				
1:45	12		5:45	12				
1:50	7		5:50	10				
1:55	6		5:55	12				
2:00	6	6	6:00	3	3			
2:05	4		6:05	1				
2:10	3		6:10	2				
2:15	9		6:15	3				
2:20	7		6:20	6				
2:25	9		6:25	6				
2:30	10	7	6:30	4	3			
2:35	9		6:35	6				
2:40	6		6:40	10				
2:45	0		6:45	10				
2:50	4		6:50	10				
2:55	4		6:55	4				

Raising Canes's Queue/Parking Study

23971 El Toro Rd., Laguna Hills

Saturday, 11 February 2023

Time	Queue	Parking	Time	Queue	Parking	Time	Queue	Parking
11:00	0	14	3:00	5	16	7:00	7	30
11:05	1		3:05	4				
11:10	2		3:10	4				
11:15	3		3:15	3				
11:20	1		3:20	1				
11:25	3		3:25	1				
11:30	1	12	3:30	4	11			
11:35	2		3:35	5				
11:40	5		3:40	4				
11:45	6		3:45	6				
11:50	10		3:50	3				
11:55	5		3:55	1				
12:00	4	13	4:00	2	21			
12:05	7		4:05	2				
12:10	9		4:10	1				
12:15	9		4:15	2				
12:20	8		4:20	2				
12:25	12		4:25	1				
12:30	6	27	4:30	1	16			
12:35	8		4:35	3				
12:40	8		4:40	2				
12:45	6		4:45	3				
12:50	10		4:50	4				
12:55	11		4:55	2				
1:00	6	29	5:00	5	22			
1:05	11		5:05	1				
1:10	8		5:10	1				
1:15	7		5:15	2				
1:20	7		5:20	3				
1:25	7		5:25	4				
1:30	7	19	5:30	8	31			
1:35	8		5:35	10				
1:40	6		5:40	13				
1:45	6		5:45	10				
1:50	10		5:50	10				
1:55	11		5:55	6				
2:00	13	30	6:00	10	31			
2:05	11		6:05	13				
2:10	11		6:10	9				
2:15	6		6:15	4				
2:20	6		6:20	11				
2:25	7		6:25	10				
2:30	6	18	6:30	11	28			
2:35	6		6:35	9				
2:40	5		6:40	8				
2:45	7		6:45	11				
2:50	7		6:50	10				
2:55	6		6:55	8-162-				