

Assessment Report & Recommendations

TeWinkle Park Lakes

June 2022 – Revised

April 2022

March 2022

Prepared For:

Seung Yang, P.E. – City Engineer
Robert Ryan – Maintenance Services Manager
City of Costa Mesa
77 Fair Drive
Costa Mesa, CA 92626

Prepared By:



Pacific Advanced Civil Engineering, Inc.
17520 Newhope Street, Suite 200
Fountain Valley, CA 92708
714-481-7300

Contact Persons:

Andy Komor, MS, PE
Zirang Song, MS, PE

PACE JN B836

Table of Contents

1 Introduction	1-1
1.1 Background Information	1-1
1.2 Lake Geometry	1-1
1.3 Previous Repairs and Modifications	1-2
1.4 Previous Rehabilitation Goals	1-2
1.5 Rehabilitation Report Objectives	1-2
1.6 Information Requested and Received from the City	1-3
2 Lake System Field Inventory	2-1
2.1 Site Visit	2-1
2.2 Existing Lake Components	2-1
2.2.1 Park Trail Features	2-1
2.2.2 Floating Fountains	2-3
2.2.3 Lake, Pond, Stream Liner and Shoreline	2-4
2.3 PACE Recommendations	2-5
2.3.1 Storm Drains and Surface Flow	2-7
2.3.2 Water Quality	2-8
2.3.3 Lake Ecology	2-11
2.4 Mechanical Components	2-13
2.4.1 Floating Fountains	2-13
2.4.2 Ponds and Stream Pump System – Pump 1	2-14
2.4.3 Lake Recirculation Pump – Pump 2	2-14
2.4.4 Existing Fill System	2-15
2.4.5 Aeration and Ozone System	2-16
2.4.6 Bio-filter Gravel Bed Intake	2-16
3 Proposed Liner Solution	3-1
3.1 30 mil Reinforced Polyethylene (RPE) Geomembrane Liner	3-1
3.1.1 Assumptions Made	3-1
3.1.2 Key Construction Features	3-1
3.1.3 Advantages and Disadvantages	3-2
4 Proposed Shoreline Solution	4-1
4.1 Rebuild Shoreline and Regrade	4-1
4.1.1 Assumptions Made	4-1
4.1.2 Key Construction Features	4-1
4.1.3 Advantages and Disadvantages	4-2
4.2 Island Regrading and Physical Barriers	4-2
5 Proposed Lake Treatment Option	5-1
The treatment options provided below include the following:	5-1
5.1 Lake Regrading and Reshape shoreline:	5-1
5.2 Aeration	5-4
5.3 Recirculation	5-6
5.4 Alum Treatment with Acid Addition	5-9
5.5 Treatment Planter/Wetland	5-13
5.6 Ozone Treatment	5-15
5.7 Filtration	5-18
5.8 Chloramine Treatment	5-18
5.9 PACE Recommendations for Lake Treatment	5-20
6 Lake Water Balance Analysis	6-1
6.1 Methods	6-1
6.2 Results and Discussion	6-3
6.3 Usage Record and Leakage	6-8
6.4 Water Balance Conclusion	6-8

6.5 Make-up Source Waters	6-9
Tables	
Table 1-1: Summary of Existing Lake Geometry	1-2
Table 2-1: Water Quality Summary.....	2-10
Table 5-1: Existing Lake and Proposed Lake Options Data	5-1
Table 6-1: TeWinkle Park Lakes Water Balance Table	6-4
Figures	
Figure 1-1-1: Park Trail Features	1-1
Figure 2-1: Pier Deck at Lake 1 with lower railing section	2-1
Figure 2-2: Maintenance Boat Dock at Pier Deck with Lockable Gate	2-2
Figure 2-3: Concrete Bridge.....	2-2
Figure 2-4: Deck.....	2-3
Figure 2-5: Wooden Bridge at Pond 1	2-3
Figure 2-6: Location of Floating Fountains	2-4
Figure 2-7: Existing Conditions/Issues at Lake Shoreline	2-6
Figure 2-8: High Elevation at Lake Shoreline	2-7
Figure 2-9: Erosion at Lake Shorelines.....	2-8
Figure 2-10: Water Sampling Locations.....	2-10
Figure 2-11: Photos of Turtle and Waterfowl	2-11
Figure 2-12: Feeding Waterfowl at TeWinkle Park	2-12
Figure 2-13: Photos of Floating Fountains at Lakes	2-13
Figure 2-14: Floating Fountain Control Panel	2-13
Figure 2-15: Pond and Stream Pump System	2-14
Figure 2-16: Lake Recirculation Pump System.....	2-15
Figure 2-17: Water Level Sensor Vault.....	2-16
Figure 3-1: 30 mil (min.) RPE Liner	3-1
Figure 4-1: Rebuild Shoreline (Regrade) w/ 30 mil. (min) RPE Liner	4-1
Figure 4-2: Proposed Island Grading.....	4-3
Figure 4-3: Proposed Island Features	4-4
Figure 6-1: TeWinkle Park Lakes Water Balance Schematic	6-1
Figure 6-2: Lakes Monthly Output.....	6-6
Figure 6-3: Lakes Monthly Input	6-7
Figure 6-4: Lakes Water Monthly Demand	6-8
Exhibit	
Exhibit 5-1: Proposed Lake Grading Option 1	5-2
Exhibit 5-2: Proposed Lake Grading Option 2	5-3
Exhibit 5-3: Lake Aeration System.....	5-5
Exhibit 5-4: Proposed Lake Recirculation System	5-7
Exhibit 5-5: Proposed Screen Intake	5-8
Exhibit 5-6: Alum Treatment of Turbid Water (Left: Untreated, Right: Treated)	5-9
Exhibit 5-7: Proposed Alum Discharge Standpipe inside Lake Planter	5-11
Exhibit 5-8: Proposed Alum Treatment with Acid Addition at Pump Station.....	5-12
Exhibit 5-9: Lakes Plan View with Aquatic Planter/ Wetland	5-14
Exhibit 5-10: Proposed Ozone Room Options at Lake Pump Station	5-17

ABBREVIATION

AR	AIR RELEASE	FLG	FLANGE	PS	PUMP STATION
AIR/VAC	AIR RELEASE & VACUUM RELIEF	GAL	GALLON	RB	REDUCER BUSHING
APP EQ	APPROVED EQUAL	GA	GAUGE	REINF	REINFORCE
BL	BALL VALVE	GPM	GALLONS PER MINUTE	RCP	REINFORCED CONCRETE PIPE
BF	BIOFILTER	GV	GATE VALVE	R/W	RIGHT OF WAY
BLDG	BUILDING	HP	HORSE POWER	SCH	SCHEDULE
BV	BUTTERFLY VALVE	HZ	HERTZ	SPECS	SPECIFICATIONS
CV	CHECK VALVE	IE	INVERT ELEVATION	SF	SQUARE FEET
CONC	CONCRETE	IRR	IRRIGATION	THK	THICK
CONT	CONTINUOUS	MFR	MANUFACTURE	TOF	TOP OF FOOTING
DIA	DIAMETER	MAX	MAXIMUM	TOP	TOP OF PAVEMENT
DIP	DUCTILE IRON PIPE	MG	MILLION GALLON	TOS	TOP OF SHORELINE
EW	EACH WAY	MIN	MINIMUM	TOW	TOP OF WALL
EOP	EDGE OF PAVEMENT	OC	ON CENTER	TDH	TOTAL DYNAMIC HEAD
EL	ELEVATION	PH	PHASE	TYP	TYPICAL
ENG	ENGINEERING	PUE	PUBLIC UTILITY EASEMENT	V	VOLTS
EQ	EQUALIZER	PVC	POLYVINYL CHLORIDE	WS	WATER SURFACE
FF	FINISH FLOOR	PSF	POUNDS PER SQUARE FOOT	WP	WETLAND PLANTER
FG	FINISH GRADE	PSI	POUNDS PER SQUARE INCH	WQF	WATER QUALITY FILTER
TBD	TO BE DETERMINED	RPM	REVOLUTION PER MINUTE	LF	LINEAR FEET
AC	ACRE	FT	FEET	AC-FT	ACRE FEET
mg/L	MILLIGRAM PER LITER				

1 Introduction

1.1 Background Information

TeWinkle Lakes, located at TeWinkle Park, 970 Arlington Drive, Costa Mesa, California, is a 2 Acre (lakes area) recreational facility with systems of lakes, ponds, and streams. The lake systems are focal points of the park with multiple waterfalls connecting streams and lakes.

In 2004, the lakes and ponds were renovated with shoreline repair, adding a lake recirculation system and installing PVC liner for the ponds to improve waterproofing. Furthermore, the lakes have several floating fountains (see section 2.2.2) to increase water circulation and aeration.

1.2 Lake Geometry

PACE engineers visited the site on 01/26/2022 and reviewed the lake and pump station's current condition. PACE also reviewed the as-built plan for existing conditions. The water surface elevation, perimeter, surface area, average depth, and maximum depth were documented. The data is summarized in Table 1-1 below. This data is based on the as-built plan and may differ from current conditions. The current lake conditions are documented in section 2 of this report. TeWinkle Park Lakes features are shown in Figure 1.1.

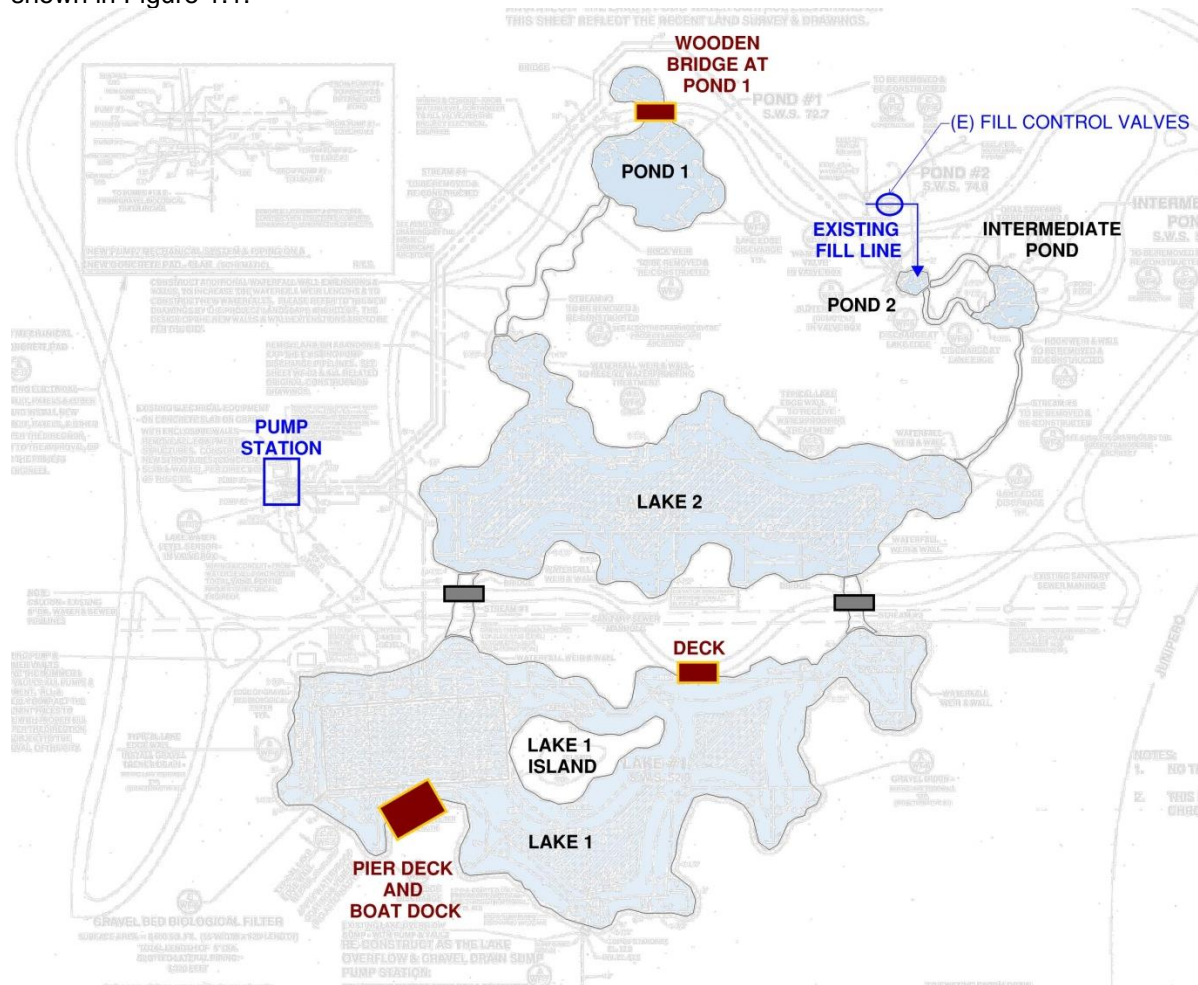

Figure 1-1-1: Park Trail Features

Table 1-1: Summary of Existing Lake Geometry

NAME	AS BUILT PLAN (Dated 07/22/2004)			
	Water Surface	PERIMETER [LF]	SURFACE AREA [AC (SF)]	MAX. DEPTH [FT]
LAKE 1	52.0	1,420	0.98 (42,800)	9
LAKE 2	54.8	1,156	0.73 (32,000)	8.8
POND 1	72.7	363	0.12 (5,442)	3
POND 2	74.0	64	0.006 (283)	3
INTERMEDIATE POND	58.8	153	0.027 (1,190)	2
STREAM 1	N/A	127	0.013 (552)	0.5 TO 1.5
STREAM 2	N/A	113	0.009 (385)	0.5 TO 1.5
STREAM 3	N/A	295	0.032 (1,400)	0.5 TO 1.5
STREAM 4	N/A	108	0.005 (210)	0.5 TO 1.5
STREAM 5	N/A	231	0.006 (285)	0.5 TO 1.5

1.3 Previous Repairs and Modifications

In 2004, the lake systems were renovated with the following items:

- Installed lake suction pipeline and bio-filter at the bottom of Lake 1
- Installed Lake 1 and Lake 2 recirculation piping inside the lakes
- Installed new discharge along the pond's shoreline
- Repaired lake shorelines to improve the waterproofing of the lakes
- Renovated the ponds and stream with new construction and 10 mil PVC liner
- Renovated the waterfall with stones and retaining walls
- Renovated the lake system at pump station with (2) recirculation pumps, ozone system, aeration/blower system, auto water level control with motor valve, and floating fountain system

1.4 Previous Rehabilitation Goals

Due to the lake liner and shoreline's declining condition, the previous rehabilitation goals were as follows:

- Develop alternatives to repair or replace the lake shoreline
- Develop Lake 1 and 2 recirculation systems to improve water movement to limit water stagnations
- Develop a water transfer system to Pond 1, Pond 2, and Intermedia Pond
- Develop a bio-filter in the bottom of Lake 1 for water filtration
- Develop a pump station enclosure to house the lake equipment, electrical and control
- Add liner, add the ponds, and repair liner at the lake's shoreline to prevent leaks

1.5 Rehabilitation Report Objectives

PACE provides this study with the following objectives:

- Identify current site conditions for Lake 1, Lake 2, Pond 1, Pond 2, Intermediate Pond, Streams, and connection waterfalls
- Identify unsafe conditions along the lake shoreline and the slope around the lake
- Evaluate issues or damages to the current lake system
- Identify any regulatory requirements that may impact the rehabilitation of the lake including safety considerations
- Provide recommendations to repair or replace the lake system and improve project features
- Provide the foundation for the renovation design

1.6 Information Requested and Received from the City

PACE requested the information listed below to better understand the system and operation of this project.

- Operation and Maintenance record and data, history of the system, and issues in operation
- City records on water and electrical usage
- Recycle water supply capacity

The City provided the following items to the PACE team:

- TeWinkle Lakes water use records, 2014 and 2017

2 Lake System Field Inventory

2.1 Site Visit

On January 26, 2022, PACE conducted initial site visits to collect data and lake inventory, inspect lake condition and investigate/review in detail the existing conditions. This section details the results of the visit.

2.2 Existing Lake Components

2.2.1 Park Trail Features

Since the lakes were designed as a focal point of TeWinkle Park, there are numbers components to serve as park trail features (locations shown in Figure 1-1).

a. Pier Deck and Maintenance Boat Dock:

Pier Deck on the south shoreline of Lake 1 is made of wood and cantilever into the lake with supports. The deck is in good condition. However, there is a lower section of the railing in the middle of the deck. See Figure 2-1.

In addition to the pier deck is a boat dock combination with a lockable gate, which can act as boat access for lake maintenance. This dock is not for recreational purposes. See Figure 2-2.

PACE recommends raising a section of low railing to match the rest of the railing height. The pier deck shall be protected and reused in the renovation. The deck support will need to be examined in more depth to confirm the foundation integrity.



Figure 2-1: Pier Deck at Lake 1 with lower railing section



Figure 2-2: Maintenance Boat Dock at Pier Deck with Lockable Gate

b. Concrete Bridges:

There are two (2) concrete bridges that connect the lake trail with the island trail. The concrete bridges are in good condition. PACE recommends that these bridges be protected in the renovation.



Figure 2-3: Concrete Bridge

c. Deck:

An existing deck with wooden guardrails at the North shoreline of Lake 1 is located on the island. This deck is part of Lake 1 shoreline which has damage and cracks inside the lake. PACE recommends keeping and reusing this deck as Lake 1 shoreline will be rebuilt.



Figure 2-4: Deck

d. Wooden Bridge at Pond 1:

There is a wooden bridge at Pond 1 that connects the lake trail from the lake to the trail toward Pond 2 and Intermediate Pond. This bridge is in good condition. It can be protected in place and reused in the renovation; however, the City may replace this bridge in the renovation design.



Figure 2-5: Wooden Bridge at Pond 1

2.2.2 Floating Fountains

A floating fountain consists of a pump and a fountain nozzle mounted on a molded plastic float anchored in the middle of a lake. Besides providing an exciting water display, floating fountains aerate and circulate pond water, promoting the growth of natural bacteria that purify the water and control the accumulation of organic matter. A properly sized floating fountain can help to keep a lake attractive and improve water quality.

PACE noted a total of six (6) existing floating fountains, three (3) fountains are at Lake 1 and three (3) fountains are at Lake 2. All fountains are functioning as expected. The floating fountains can be removed, protected, and reused during the lake renovation. Locations are shown in Figure 2-6.

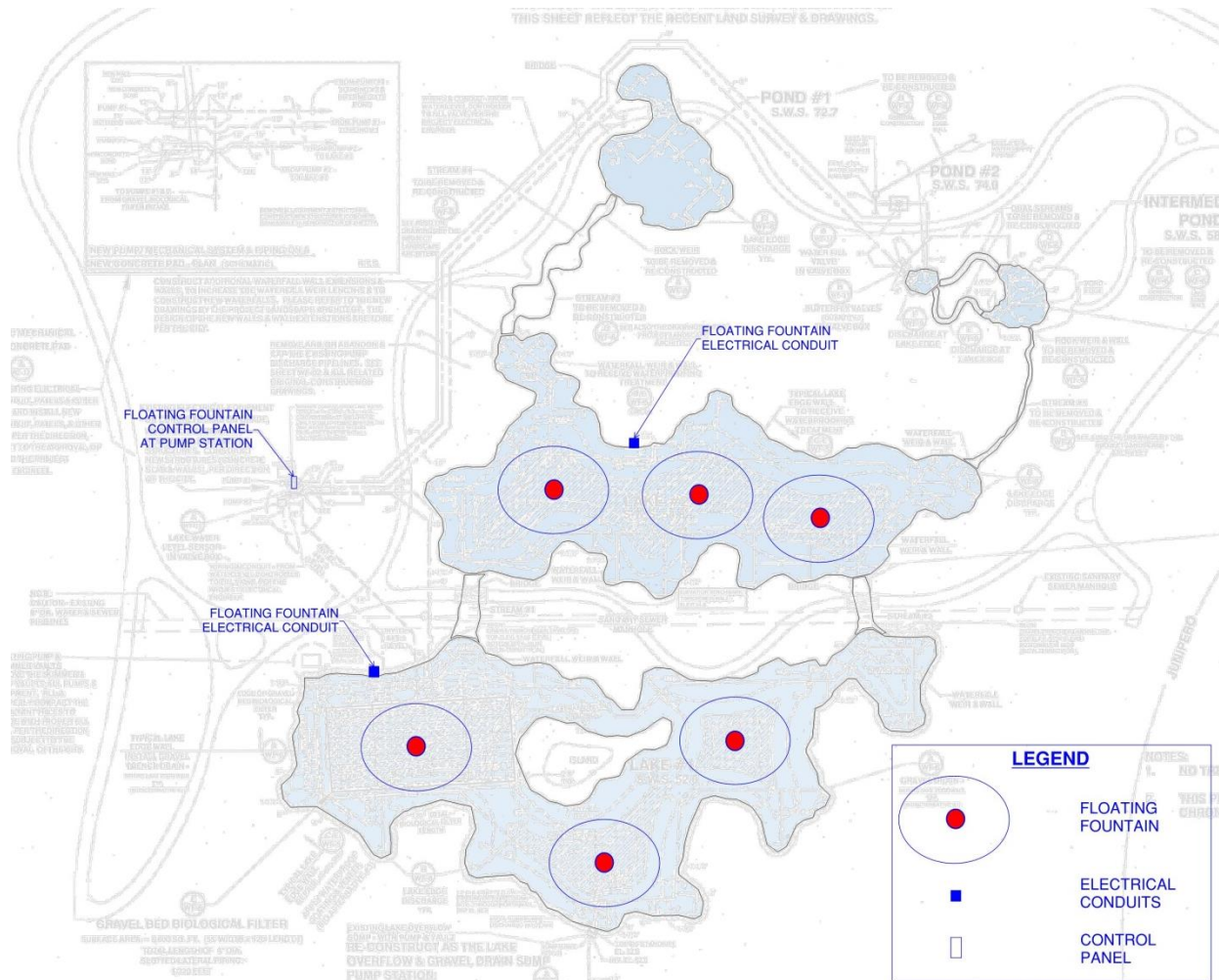

Figure 2-6: Location of Floating Fountains

2.2.3 Lake, Pond, Stream Liner and Shoreline

During the site visit by PACE, broken PVC liners were observed in several locations. Major water leaks behind sections of lake shorelines were also noticed. A water use estimate is performed in Section 6 based on historical evaporation data and empirical fountain water loss data.

When inspecting the lake shoreline, PACE referenced the as-built plan for the lake edge detail (See Appendix A). The shoreline slope of 4V:1H, shoreline depth of 21" and water depth of 4". The shoreline is a combination of an old concrete wall and a new soil cement layer added during the 2004 renovation.

The shoreline has some major cracks and leaks. At three shoreline areas, the water penetrated through the shoreline. Inside the lake, the concrete veneer was heavily damaged with 3 to 6 inches of concrete cracks. The top of the shoreline appeared to have major erosion due to the stiff slope and no erosion protection landscape. Furthermore, tree roots along the shoreline are also a major problem that can damage the lake. Tree roots can lift up the shoreline or puncture the liner. See Figure 2-7 for the typical shoreline issues and damage.

PACE observed many portions of the lake shoreline that are at a high elevation for public access. In some areas, the shoreline drop is more than 7 feet from the lake bottom. See Figure 2-8 for the high elevation shoreline.

The pond and stream liner and shoreline appear to be in fair condition. Some repairs are needed.

2.3 PACE Recommendations

Lake liner - The existing lake liner shall be removed and replaced with a new liner to make sure the lake is watertight. See Section 3 – Proposed Liner Solution for more details.

Lake shoreline - Remove the existing shoreline and rebuild a new lake shoreline. The proposed lake shorelines have eroded concrete shoreline type, gabion wall, and boulder pocket shoreline type to match the existing. The new shoreline will be installed with a liner extended to the top of the shoreline for waterproofing. The shoreline liner is connected to the lake liner to make a complete waterproofing vessel for the lake. See Section 4 – Proposed Shoreline Solution for more details.

Lake concrete shelf - New concrete veneer shall be installed as part of the shoreline to protect the liner underneath in shallow water area.

Landscape along the shoreline - Local regrading may need to be done to reduce the slope to a safe slope of 3:1 or 5:1. Alternatively, boulders can be added along the lake shoreline to serve as a barrier. The tree roots shall be cut back behind the shoreline. Any trees that are close to the shoreline shall be removed or relocated to protect the lake shoreline from damage by trees.

Unsafe conditions along the shoreline - Hedges, boulders or guardrails shall be installed to protect the public from walking into these areas.

Pond and streamliner and shoreline - The pond and stream shall be protected in place and repaired for minor damage.



a) Major Crack and Leak Shoreline

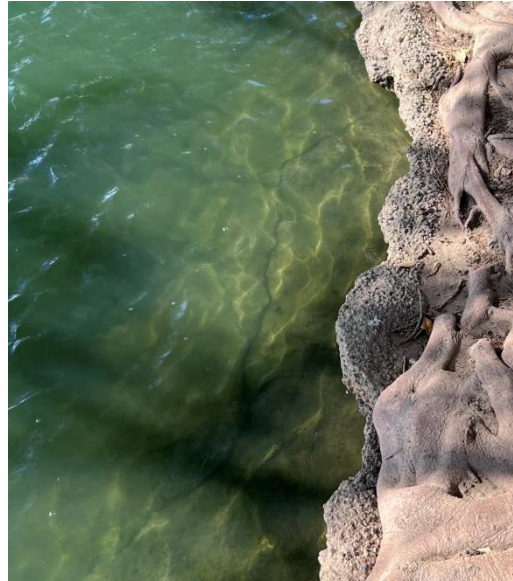

b) Concrete Veneer Crack



c) Stiff Slope at Shoreline



d) Erosion Behind the Shoreline



e) Tree Roots at Shoreline

Figure 2-7: Existing Conditions/Issues at Lake Shoreline



Figure 2-8: High Elevation at Lake Shoreline

2.3.1 Storm Drains and Surface Flow

During the site visit, PACE determined that there are no storm drain pipes connecting to the lakes or any of the ponds. However, the surface stormwater is an issue for this site. PACE observed heavy erosion happening along the lake shoreline, especially the area with a steep slope.

PACE recommends that the slope be regraded into a shallow slope of 3:1 to 5:1 and landscape installed to limit the erosion.



Figure 2-9: Erosion at Lake Shorelines

2.3.2 Water Quality

While onsite January 26, 2022, PACE took three (3) 250ml water samples (location per Figure 2-10) for water quality analysis. A water quality analysis was performed by a PACE lab technician with the result summary in Table 2-1. If required, further testing and water source samples shall be collected and analysis be done to serve as a design guideline for the lake treatment design.

The existing lake water will be drained before lake demolition work. There will be a “Special Purpose Discharge Permit” required from OCSD for a one-time water discharge to the sewer system. Contractor will be responsible for the permit application and to locate a suitable sewer manhole for the lake water discharge.

The target water quality column shown in Table 2-1 is the key water quality that PACE targets for the lake. The treatment method and solution will be designed during the design phase. The parameters below are the key water quality for the lake design.

pH: Typical freshwater lakes and ponds usually have a pH of 7-8. The pH level is important to plants and animal life. Most of the fish and animals cannot survive if water is too acidic (below 5.0) or too basic (above 9.0). The Lakes and Ponds at TeWinkle Park pH level is range from 8.06 to 8.45 which is slightly basic. A small scale manual acid treatment will improve the pH to the target level.

DO: Dissolved oxygen (DO) is the amount of oxygen dissolved into a body of water. Typical freshwater lakes and ponds usually have a DO level of 5 mg/L or more. The DO level will provide oxygen to fish, aquatic animals and keep the algae under control. The Lakes and Ponds at TeWinkle Park DO level is range from 11.02 to 12.89 which is in the acceptable range. The lakes and ponds have high DO levels because of high wind and floating fountains on the lakes. The aeration system is another method to keep the DO level high and stable.

Turbidity: Turbidity is the parameter to measure the amount of suspended solid or algae in the water that scatter light making the water appear cloudy or murky. Particulate matter can include sediment especially clay, silt, fine organic and inorganic matter, algae, and other microscopic organisms. Turbidity is measured using specialized optical equipment (Secchi Disk). The target turbidity is Secchi disk reading no less than 3 feet underwater. The turbidity of the Lakes and Ponds at TeWinkle Park is range from 6.82 to 13.4 feet which is not ideal. Filtration and/or Alum treatment will improve the turbidity of the water. The filtration system will remove the algae and fine particles out of the water. Similarly, Alum treatment will facilitate fine particles settle down at the alum standpipe and vacuum out of the lake.

Ortho-P: Orthophosphate (Ortho-P or PO_4) is the phosphorus form that is directly taken up by algae and the concentration of this fraction constitutes directly to algal growth. Ortho-P level shall be less than 0.05 mg/L. The Ortho-P level of the Lakes and Ponds at TeWinkle Park is range from 0.85 to 0.88 mg/L which is on the high side of the acceptable range. Alum treatment will remove Ortho-P by coagulation process and settle down into the alum standpipe then vacuum out of the lake.

Ammonia: Ammonia is one of the forms of nitrogen that exist in the aquatic environment. Unlike other forms of nitrogen, which can cause over-enrichment of the water body, ammonia causes direct toxic effects on aquatic life. Ammonia level shall be less than 0.5 mg/L in a body of water. The ammonia level of the Lakes and Ponds at TeWinkle Park is in the range of 0.13 to 0.15 mg/L which is in the acceptable range.

Nitrate: Nitrate is one of the forms of nitrogen that can cause over-enrichment of the water. Nitrate level is directly related to algae growth. The nitrate level shall be less than 2 mg/L. The nitrate level of the Lakes and Ponds at TeWinkle Park is in the range of 4.1 to 4.4 mg/L which is not in the acceptable range. Alum treatment will remove Nitrate by coagulation process and settle down into the alum standpipe then vacuum out of the lake.

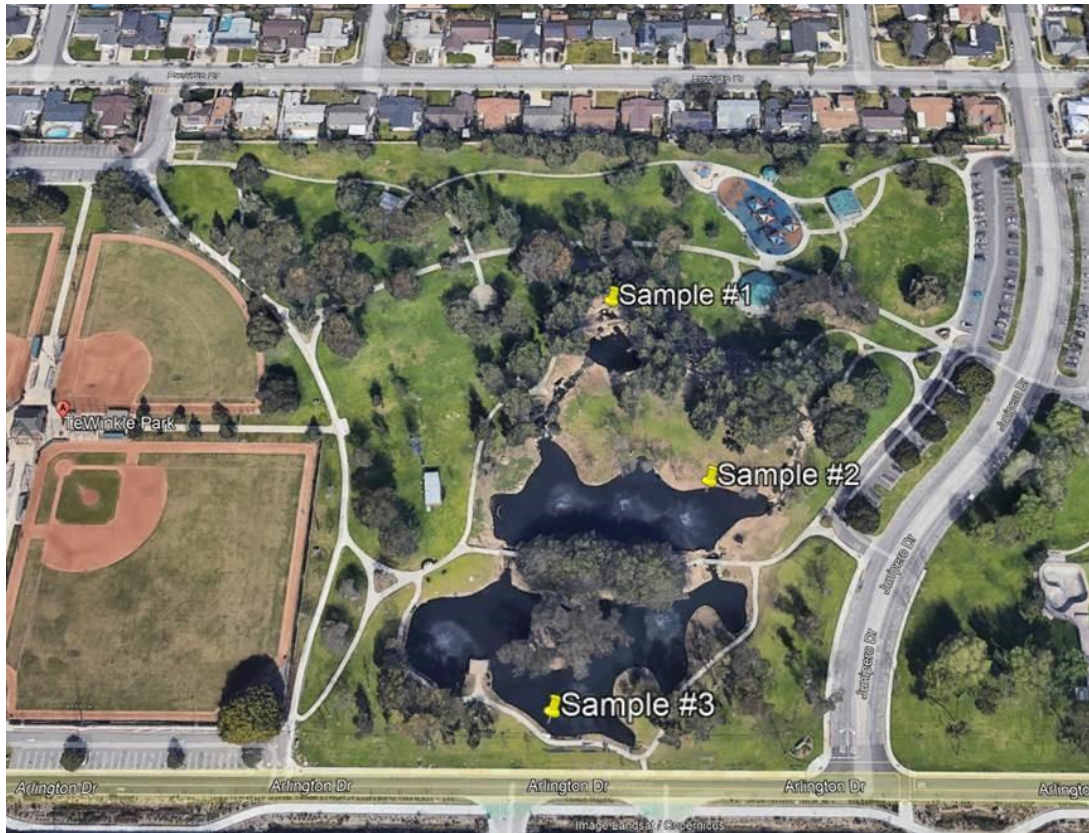

Figure 2-10: Water Sampling Locations

Table 2-1: Water Quality Summary

TeWinkle Park, Costa Mesa, CA					
	Unit	Sample 1	Sample 2	Sample 3	Target Water Quality
pH	N/A	8.06	8.26	8.45	7 to 8
DO	mg/L	11.02	11.44	12.89	Above 5 mg/L
Temp	Celsius	14.8	13.7	13.7	Less than 72 °F
Turbidity	NTU	8.61	6.82	13.4	Secchi disk(*) reading no less than 3 feet
Ortho-P	mg/L	0.86	0.88	0.85	Less than 0.05 mg/L
Ammonia	mg/L	0.13	0.14	0.15	Less than 0.5 mg/L as N
Nitrate	mg/L	4.4	4.1	4.4	Less than 2 mg/L

Notes:

Not all tested parameters are shown in the table.

(*) Secchi Disk is an opaque disk, typically white, used to gauge the transparency of water by measuring the depth (called Secchi depth) at which the disk ceases to be visible from the surface.

2.3.3 Lake Ecology

a. Wildlife:

During the TeWinkle Lakes site visit, PACE observed a high count of waterfowl. It was estimated to have about 500 waterfowl (geese and duck). The waterfowl with their waste is a major issue for lake water quality. In addition to waterfowl, there is a low number of fish and turtles inside the lakes. See Figure 2-12.

The main reason for the high number of waterfowl is due to direct feeding by the public. During the site visit, multiple people were feeding ducks and geese in Lake 1, Lake 2, and Pond 1 areas. Furthermore, these feeding activities happen almost daily, on the sidewalk and/or inside the lake. This will make the lake water quality reduced and the lake will become polluted with wildlife waste. See Figure 2-13 for an example of feeding activity on site.

If the lake were to be drained, then the fish, waterfowl, and turtles will need to be removed. Healthy waterfowl will move on their own, while others will require assistance. There are turtles associations and groups that will help relocate turtles. To remove the fish, the lake should be drained until it is 1 to 2 feet in depth. The fish will then be gathered and transported to other bodies of water, such as ponds for sorting and protection.

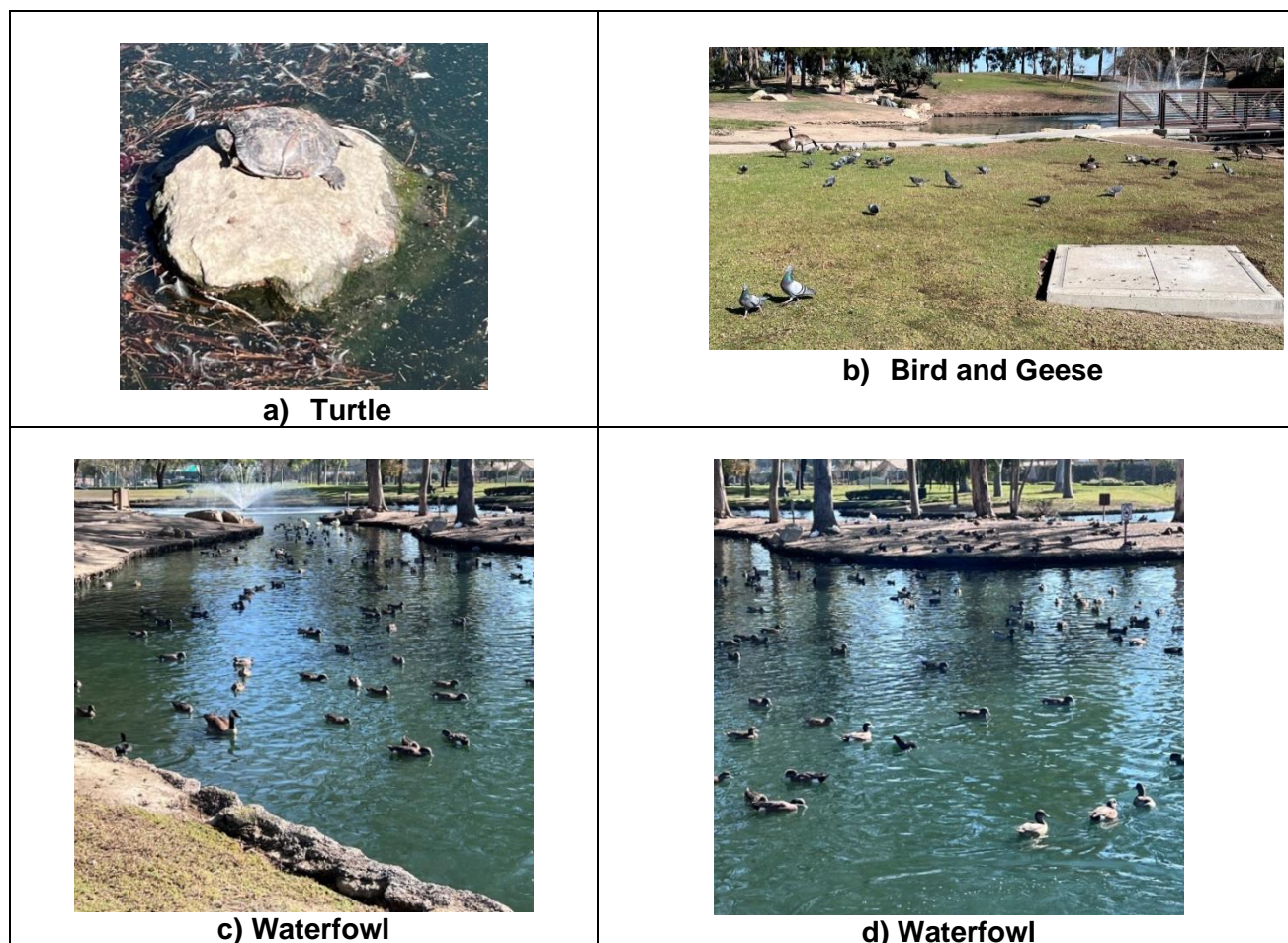

Figure 2-11: Photos of Turtle and Waterfowl



Figure 2-12: Feeding Waterfowl at TeWinkle Park

PACE recommends that the shoreline be installed with hedges, high walls, and aquatic planters to keep the waterfowl inside the lake or on the small island at Lake 1 so that the lake trail can be cleaned of waste and clear from ducks or geese.

b. Rocks and Plants Around Lake Shoreline:

There are numerous rocks and plants around the lake shoreline and inside the lake. Anything salvageable (i.e. plants and rocks) can be saved and stored while the rest will be discarded.

2.4 Mechanical Components

2.4.1 Floating Fountains

The floating fountain system at TeWinkle Park Lake is controlled by the panel inside the pump station to the three (3) floating fountains at Lake 1 and the three (3) at Lake 2. The mechanical and control of the floating fountains are functional and in good condition.

PACE recommends removing, protecting, and reusing the floating fountain systems for the renovation.

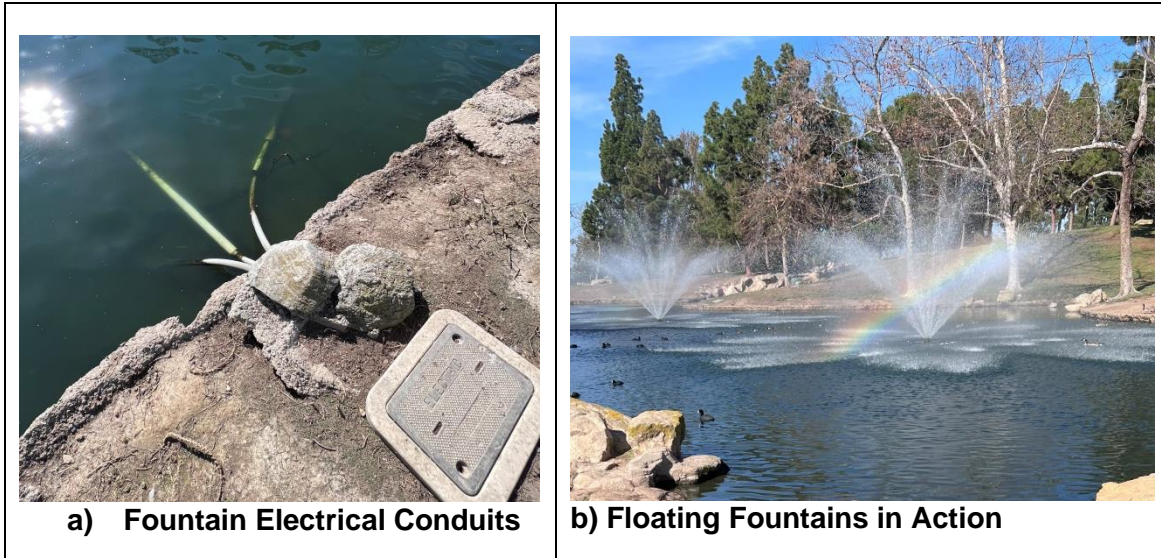

Figure 2-13: Photos of Floating Fountains at Lakes



Figure 2-14: Floating Fountain Control Panel

2.4.2 Ponds and Stream Pump System – Pump 1

During the site visit, it was observed that Pump 1 is used for pond water transfer. Pump 1 (Figure 2-15) has a flow of 1,600 GPM at 33 FT, 20 HP, 460V, 3PH, and 1170 RPM. The pump was operating, but the PACE engineer could not verify the performance of the pump due to the broken pressure gauge and lack of a flow meter.

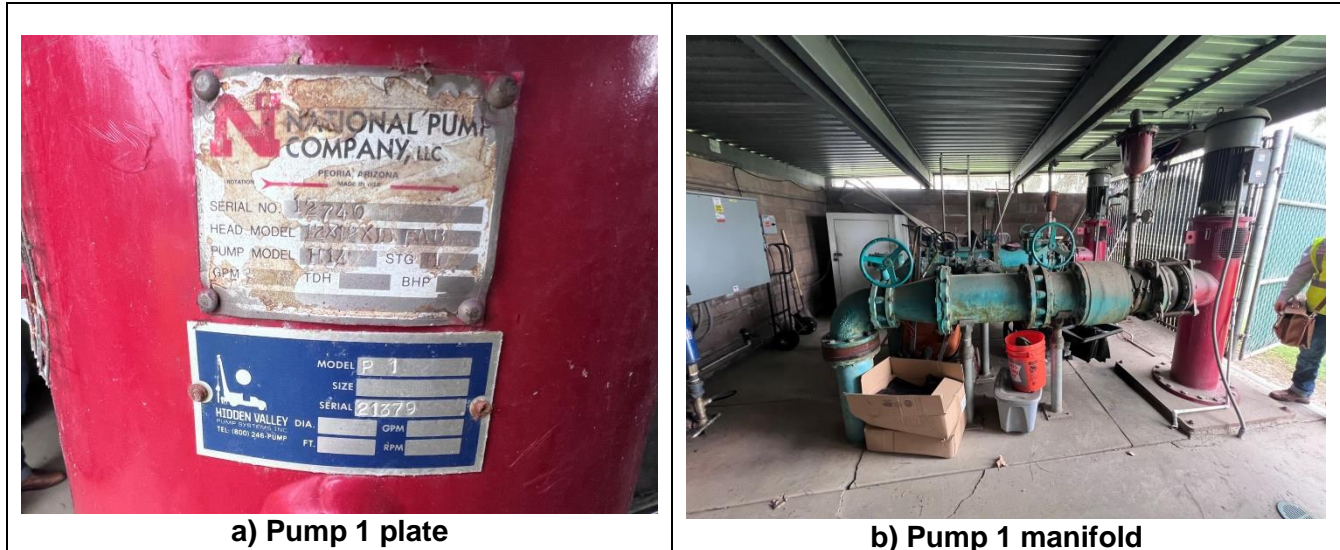

Figure 2-15: Pond and Stream Pump System

The existing water transfer pipe system appeared to be in good condition and most of it can be reused. The discharge points at the ponds are exposed along the pond shoreline. The discharge point can be redesigned to make the discharge pipe below water to protect the pipe from public access. The existing pipelines are shown on sheet WF-03 of the as-built plan (Appendix A).

PACE recommends pressure testing the existing pipe for any pipe leakage before deciding to reuse the pipe section. The pump shall be tested for performance, and rebuilt (as needed) before being reused in the renovation.

2.4.3 Lake Recirculation Pump – Pump 2

During the site visit, it was observed that Pump 2 was used for lakes recirculation. Pump 2 (Figure 2-16) has a flow rate of 2,000 GPM at 17.5 FT, 15HP, 460V, 3HP, and 1170 RPM. The pump is not operating.

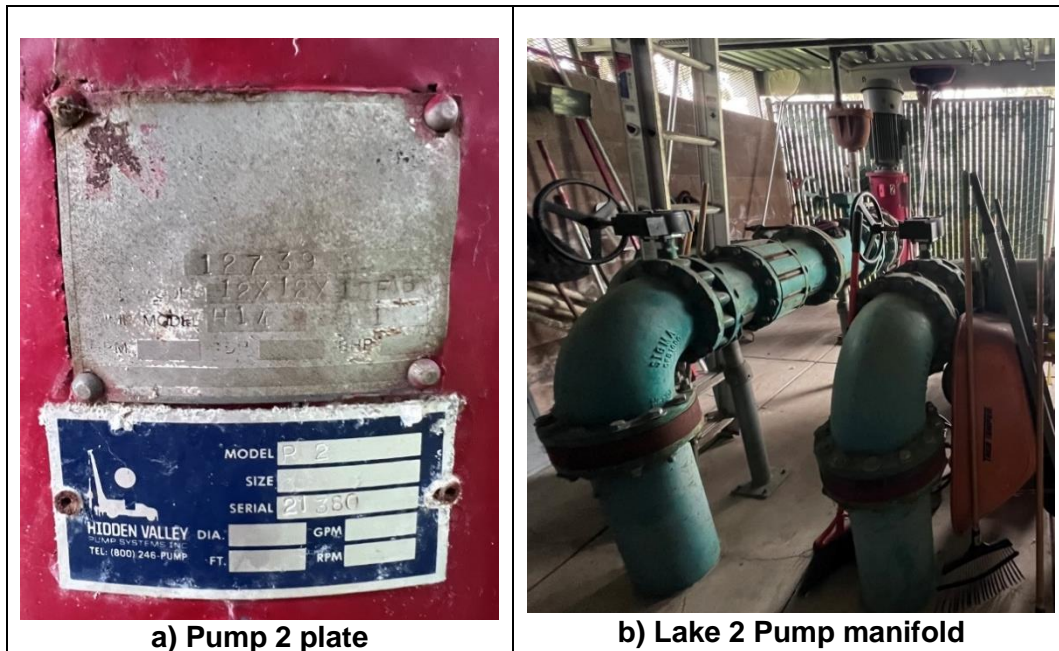

Figure 2-16: Lake Recirculation Pump System

The existing recirculation pipes inside the lakes are in bad condition with a floating pipe section at Lake 2 and many exposed piping inside the lakes. The existing pipelines are shown on sheet WF-03 of the as-built plan (Appendix A).

PACE recommends pressure testing the existing pipe for any pipe leakage before deciding to reuse the pipe section. The pump shall be removed, tested, and reused if the pump condition is good. If the pump is in bad condition, a new pump will replace this pump. In the design phase, the recirculation system will be designed and a pump will be sized according to the new system.

2.4.4 Existing Fill System

The fill line is controlled by a 2" motorized valve near Pond 2 for a potable water supply line. The water level sensor and control are located in the underground vault near the pump station. There was water inside the vault due to rainfall (Figure 2-17).

PACE recommends core drilling the bottom of the vault to drain the water into the ground.



Figure 2-17: Water Level Sensor Vault

2.4.5 Aeration and Ozone System

The existing aeration and ozone system did not work during the site visit.

PACE recommends removing aeration/ozone equipment and piping (under the lakes). The Aeration and Ozone system equipment is critical for lake water quality. PACE will design a new system for this project during the design phase.

2.4.6 Bio-filter Gravel Bed Intake

Biology filter (bio-filter) is a way to filter lake water before the pumps, using a gravel bed as filtration media. The gravel will stop debris, algae, and sediment from getting into the pump suction. However, the bio-filter will require high maintenance and complex cleaning procedure. Also, the bio-filter can be clogged due to debris and sediments.

PACE recommends removing the bio-filter and using a screened intake pump station intake pipe. See Appendix B for the screen intake detail.

3 Proposed Liner Solution

PACE recommends replacing the existing liner with 30 mil (min.) Reinforced Polyethylene (RPE) geomembrane liner as discussed below:

3.1 30 mil Reinforced Polyethylene (RPE) Geomembrane Liner

The second liner alternative is to replace the existing liner with an RPE liner that has a minimum thickness of 30 mil. The RPE liners can typically last for 30-50 years and can reduce the lake water loss through seepage by almost 100%.

3.1.1 Assumptions Made

- The lake will be drained. The lake can be drained to the storm drain or sewer depending on lake water quality at the time of construction. Lake draining can be done with a trash pump or submersible pump.
- Floating Fountains will be removed during geomembrane liner installation and replaced on completion
- Wildlife will be relocated
- Existing soils are suitable for geomembrane liner subgrade support
- The liner will be removed
- Silt and bottom debris will be removed. Testing will be required to determine landfill locations suitable for disposal.
- The concrete shoreline will be replaced per section 4 – Proposed Shoreline Solution

3.1.2 Key Construction Features

- The lake needs to be fully drained
- The current liner, fountains, wildlife, and silt debris need to be removed
- The new 30 mil (min.) RPE liner would be installed and the RPE liner will be mechanically sealed to the new shoreline with a pin and strap (*Section 4 – Proposed Shoreline Solution*)

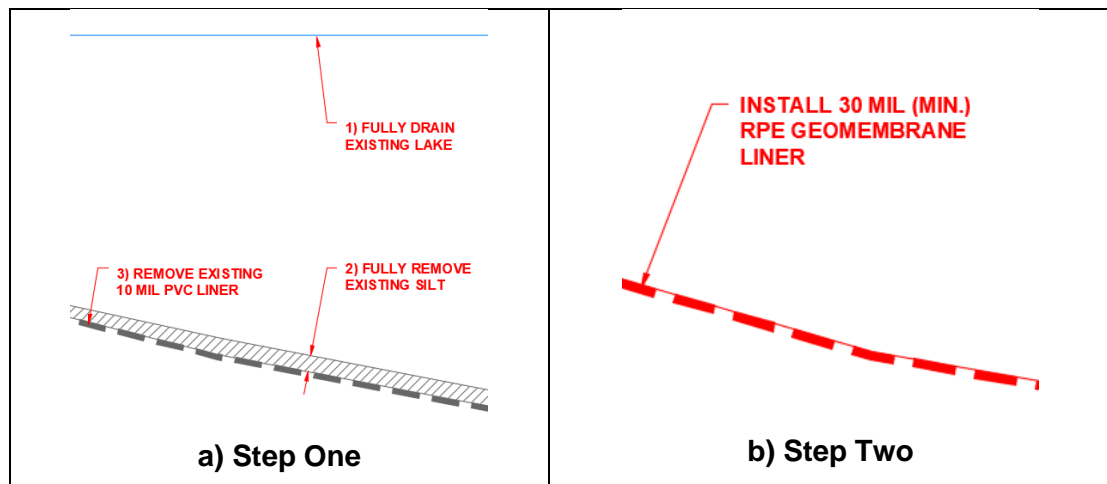

Figure 3-1: 30 mil (min.) RPE Liner

3.1.3 Advantages and Disadvantages

3.1.3.1 *Advantages*

- A new 30 mil RPE liner is flexible and can handle soil settling and geologic events better than other soil lining systems.
- The RPE liner can be installed under a new concrete shoreline to provide the most watertight liner option.
- RPE liners are resistant to ultraviolet (UV) rays and chemicals, the RPE liners do not need to covering where sunlight can reach, typically 6 feet below the water surface.
- Unlike other membrane liners, like high-density polyethylene (HDPE) and low-density polyethylene (LDPE), RPE is thinner and lighter, making the liner easier and less expensive to ship and install.
- This is the lowest seepage loss alternative. RPE liner has a very small permeability, so once the lake is filled back up, there can be almost no water loss from the lake through seepage.

3.1.3.2 *Disadvantages*

- Requires the lake to be entirely drained to expose the lake bottom. This includes the removal/relocation of wildlife. Draining the lake may expose soil that causes short-term odor problems.
- The RPE liner service life is less than soil liner and may need to be replaced every 30-50 years.
- Geomembrane liners are susceptible to damage by vandalism or tear by puncture in shallow areas not covered with concrete.

4 Proposed Shoreline Solution

The existing shoreline has areas with significant damage in which repair may not be a viable option. The concrete shoreline serves the purpose of providing erosion protection of the steeply graded shoreline section.

The existing shoreline does not comply with recreational & park recommendations for the top of shoreline elevation and nearshore slope ratios. It does not meet industry standards for safe ingress/egress if a non-swimmer were to find themselves in the lake.

Modifying the shoreline geometry to comply with industry standards would require extensive regrading. The slope along the shoreline shall be regarded to increase the safety of lake access.

PACE recommends demolishing, rebuilding a new shoreline, and re-grading the slope around the lake shoreline. This solution is most suitable with liner options where a new liner system is installed (*Section 3 – Proposed Liner Solution*). A new liner system and a new shoreline could provide up to 100% water-tight installation based on the liner decision.

Part of the shoreline solution is to focus on the wildlife and waterfowl issues at the park. Waterfowl (ducks, geese) walk around the park and contaminate the park with their waste. To alleviate this issue, PACE recommends installing physical barriers on land (fence, hedges, etc.) and underwater (gabion wall and planter along shoreline) at certain locations to create waterfowl habitat areas.

4.1 Rebuild Shoreline and Regrade

This shoreline alternative is to drain the lake, remove the existing shoreline, and build a new one over it. This shoreline option works best with liner alternatives where a new liner system is installed.

4.1.1 Assumptions Made

- Compatible with new liner 30 mil RPE liner
- Some trees too close to the shoreline should be removed to prevent future damage to the shoreline
- Pier deck and concrete trail along the shoreline should be removed, while the ones that can be worked around can be left in place.
- Lake would be drained completely, as liner solution (*Section 3 – Proposed Liner Solution*)
- All portions of the shoreline will be removed
- The entire shoreline would be rebuilt at one time

4.1.2 Key Construction Features

4.1.2.1 30 mil (min.) RPE Liner Solution

- Excavate fill material from the deeper portion of the lake and regrade the lake near the shoreline so the shoreline water depth is 18 inches and the slope near the shoreline is 1V:4H
- Install 30 mil (min.) RPE liner along all of the lake and shoreline
- Concrete would need to be transported onsite to install a new 4-inch-thick (min.) shoreline with a wire

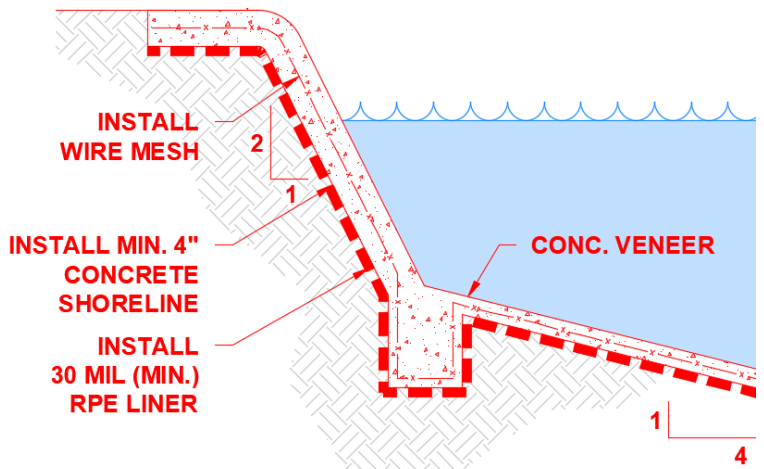

Figure 4-1: Rebuild Shoreline (Regrade) w/ 30 mil. (min) RPE Liner

- mesh, 2V:1H slope until 18-inch water depth, and 8-inch by 8-inch keyway at the bottom of the new shoreline.
- Install 2-inch (min.) thick concrete veneer with a wire mesh and 1V:4H slope until 3 feet water depth

4.1.3 Advantages and Disadvantages

The following advantages and disadvantages are only for the shoreline alternatives.

4.1.3.1 *Advantages*

- The completed shoreline is thicker, uniform in appearance, and reinforced
- A liner will be installed below the new concrete shoreline to minimize seepage loss through the shoreline section
- The new shoreline slope (2V:1H) is less steep and easier to build than the existing shoreline slope (5V:1H)
- New shoreline water depth (18 inches) is safe, according to industry standards
- Trees and boulders along the shoreline will be removed

4.1.3.2 *Disadvantages*

- Lake needs to be fully drained. Draining the lake may expose soil that cause short-term odor problems.
- Wildlife, pier deck and walkways will need to be removed
- Requires excavation of soil in deeper portions of the lake to regrade
- Most expensive shoreline alternative

4.2 **Island Regrading and Physical Barriers**

In order to keep the duck inside of the lake and on part of the island, island grading, shoreline barrier, and ground barriers shall be incorporated into the Lake renovation design. Boulders and gabion walls combined with aquatic planters are a great barrier along the shoreline to keep the waterfowl inside the lakes and out of the other areas of the park. See Exhibit 5-9 for shoreline with gabion wall and planter. Waterfowl will need some dry land. Part of the island can be used as a wildlife habitat. The island in this area will be graded and equipped with drain sumps for ease of cleaning. Ground barriers will be installed to separate the wildlife and other areas of the island.

The island finish grade will be built up 6 inches or more to protect exposed tree roots. The island concrete walkway is rerouted to a higher ground to give the wildlife more space along the island shoreline. Ground barriers such as gabion wall, log wall and plant hedge are installed along the walkway to separate the wildlife with the walkway and park activities. Gates will be provided for access to the wildlife area for interaction and maintenance as needed. For maintenance, the ground of the island shall be artificial turf or stabilized decomposed granite (DG) for easy cleaning and wash the waste toward the drain sump. See figure 4-2a, 4-2b for the artificial turf/ DG finish on the island and Figure 4-3 for proposed island grading and features.

The drain sumps are designed to connect to each other and slope toward the lowest sump for water drainage. In the lowest sump, a sump pump will pump waste water into the existing sewer system.



a. Artificial Turf

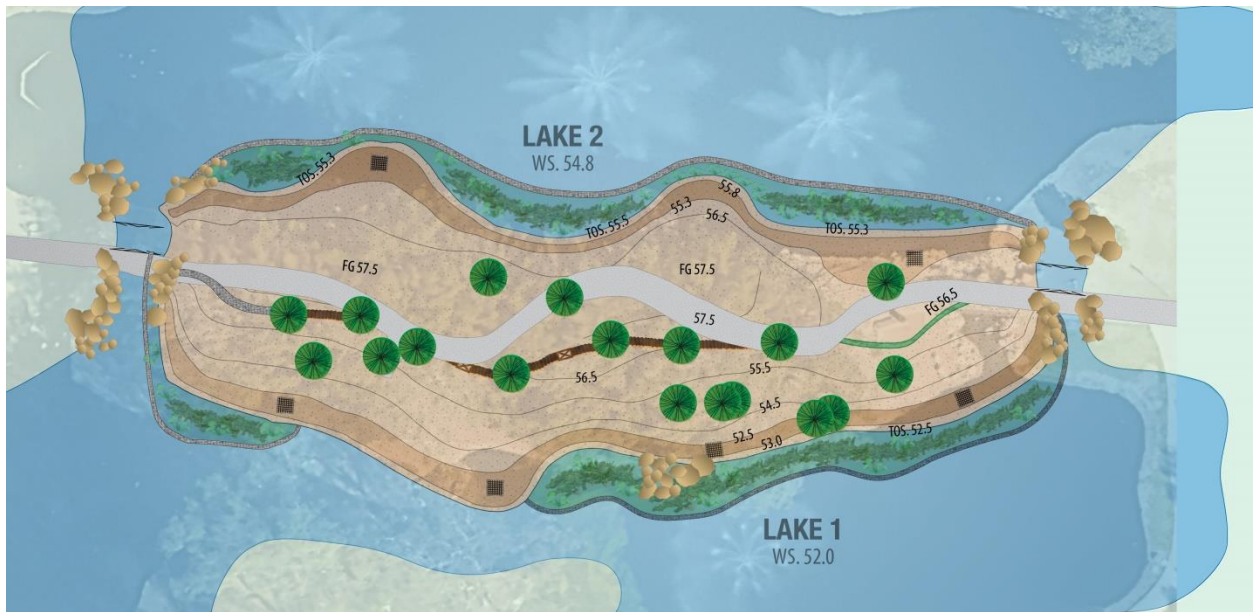

b. Decomposed granite (DG)

Figure 4-2: Proposed Island Grading

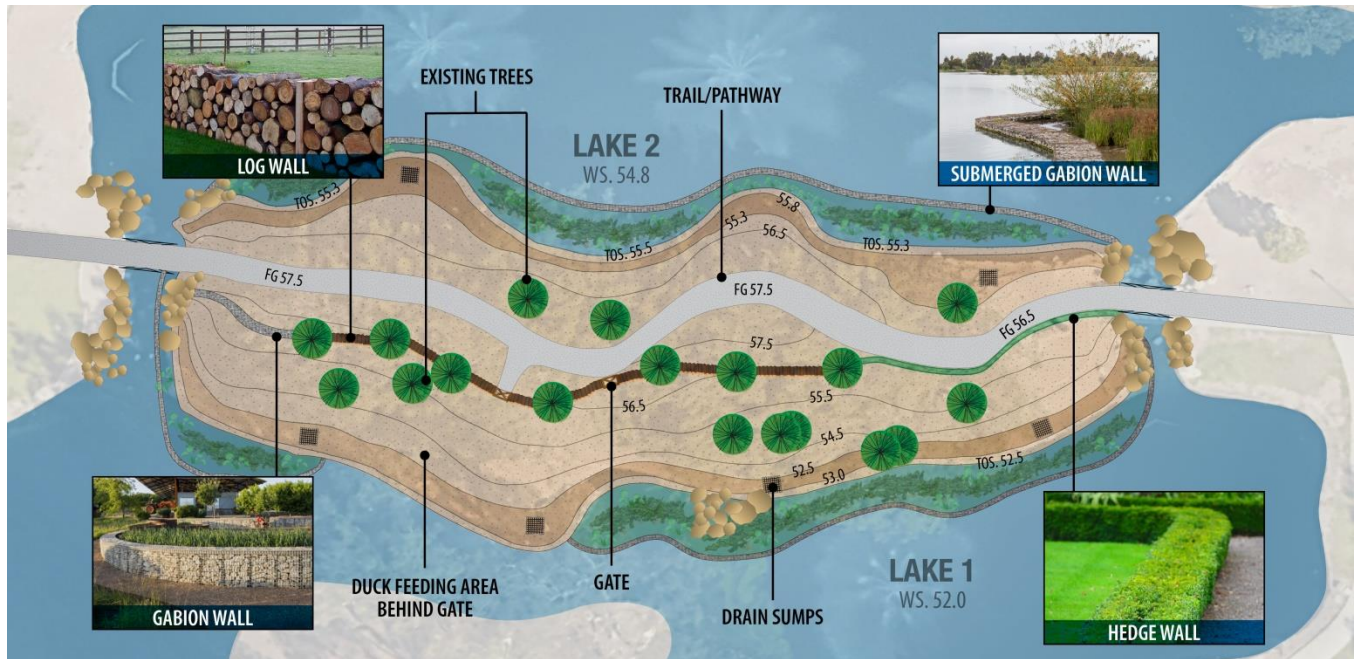

Figure 4-3: Proposed Island Features

5 Proposed Lake Treatment Option

Part of the design and rehabilitation requires determining a treatment system that can be designed for the lakes. Portable water is the main water source to fill the lake. Based on the lake usage, functionality, and existing condition from the sections above, PACE provides possible treatment options and recommendations.

The treatment options provided below include the following:

- 5.1 Lake Regrading and Reshape shoreline
- 5.2 Aeration
- 5.3 Recirculation
- 5.4 Alum Treatment
- 5.5 Treatment Wetland
- 5.6 Ozone Treatment
- 5.7 Filtration
- 5.8 Chloramine Treatment

5.1 Lake Regrading and Reshape shoreline:

PACE recommends regrading and reshaping the lakes to improve flow patterns, limit stagnation corners, and to allow for the storage of more water. There are two regrading options:

Option 1: PACE proposes to keep as much of the Lake 2 shoreline as possible, regrade inside the lake and add planters along the shoreline. The small island and two peninsulas on the southeast end will be removed from Lake 1. The lake will be regraded and planters along the shoreline will be added. See Exhibit 5-1.

Option 2: PACE proposes to regrade Lake 2 in the same way as option 1. The changes are similar at Lake 1 to option 1, but the island is to remain unchanged. Lake 1 is regarded to make it deeper. See Exhibit 5-2.

For the planter (Section 5.5), a gabion wall will be added along most of the lake shoreline to form the planter. A gabion wall is a large wire cage (typical 3'x3'x3' section) filled with rocks inside to create a wall. A gabion wall combined with filter fabric will keep the soil back and let the water through. The gabion wall will be raised 8 to 12 inches above water level.





















The planters and gabion wall around the lake's shoreline will act as a barrier to keep the waterfowl (ducks, geese) inside the lake and off of the sidewalk. The treatment options discussed below are based on lake grading option 1. The existing and proposed lakes data is organized in Table 5-1 below.

Table 5-1: Existing Lake and Proposed Lake Options Data

	Existing Grading		Option 1 Grading		Option 2 Grading	
	Lake 1	Lake 2	Lake 1	Lake 2	Lake 1	Lake 2
VOLUME (GAL) (*)	1,681,500	1,120,700	2,144,100	946,000	1,120,700	946,000
SURFACE AREA (ACRES)	0.95	0.66	1.1	0.66	1.0	0.66
SHORELINE LENGTH (FT)	1,600	1,160	1,110	960	1,110	960
DEPTH (FT)	9	8.8	10	8.8	10	8.8
NORMAL WATER ELEVATION	52.0	54.8	52.0	54.8	52.0	54.8

(*) Existing Volumes of the lakes are estimated from the as-built plan dated 07/22/2004.

LEGEND:

-  SHADED AREA INDICATES LIMIT OF CONCRETE
-  INDICATES SHORELINE
-  INDICATES SHORELINE HINGE POINT
-  INDICATES BOULDERS WITH GRADUATED SIZES
 2'φ = 10%
 3'φ = 20%
 4'φ = 40%
 5'φ = 20%
 6'φ = 10%
-  INDICATES RIVER COBBLE SHELL
-  INDICATES DISCHARGE RISER
-  INDICATES RECIRCULATION DISCHARGE PIPE AND SIZE SEE GENERAL NOTES #2 & #3
-  INDICATES RECIRCULATION INTAKE PIPE AND SIZE
-  INDICATES RECIRCULATION FLOW IN GALLONS PER MINUTE @25%
 1000
-  INDICATES WETLAND PLANTER
-  INDICATES TOTAL EFFECTIVE WEIR LENGTH
-  INDICATES TOP OF WEIR ELEVATION
-  INDICATES WATER SURFACE ELEVATION
-  INDICATES FINISH BOTTOM ELEVATION
-  INDICATES DETAIL LETTER DESIGNATION
-  INDICATES SHEET LOCATION
-  FOOT INDICATES SECTION DIRECTION
-  INDICATES AERATION VALVE BOX
-  INDICATES 3/4" WEIGHTED AERATION TUBING
-  INDICATES AREA OF INFLUENCE
-  INDICATES AERATION POD

NOTE: NOT ALL SYMBOLS MAY BE USED.

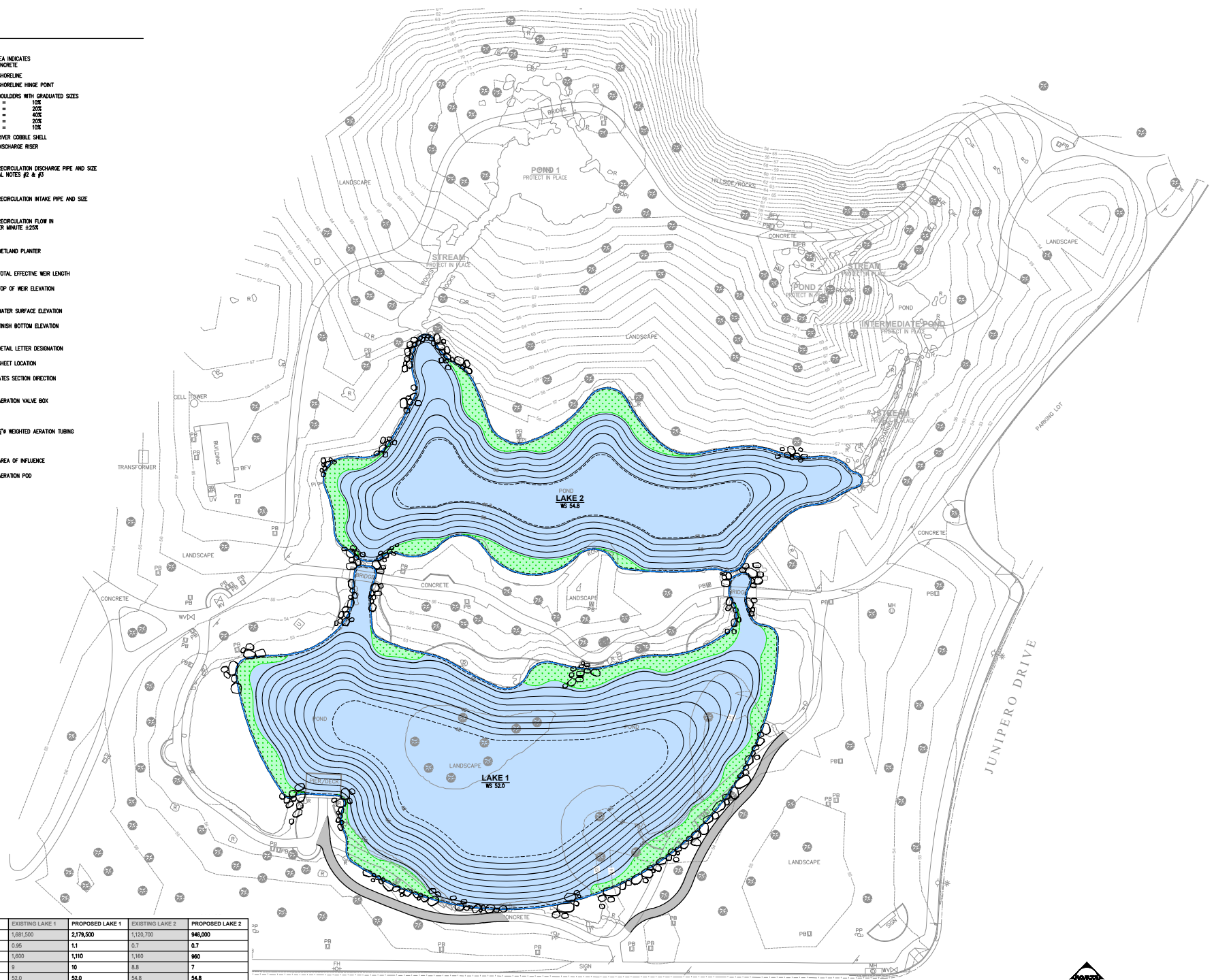

LAKE DATA

	EXISTING LAKE 1	PROPOSED LAKE 1	EXISTING LAKE 2	PROPOSED LAKE 2
VOLUME (GALLONS)	1,681,500	2,178,500	1,120,700	948,000
SURFACE AREA (ACRES)	0.95	1.1	0.7	0.7
LENGTH OF SHORELINE (FT)	1,600	1,110	1,160	960
DEPTH (FT)	9	10	8.8	7
NORMAL WATER SURFACE ELEVATION (FT)	52.0	52.0	54.8	54.8

NOTE: LAKE DATA SHOULD BE CONSIDERED AS ENGINEER'S ESTIMATE ONLY. LAKE CONTRACTOR SHOULD INDEPENDENTLY VERIFY QUANTITIES.

PLAN VIEW

EXHIBIT 5.1 - PROPOSED LAKE GRADING - OPTION 1

May 12, 2022

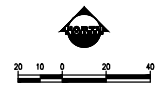

LEGEND:

- SHADED AREA INDICATES LIMIT OF CONCRETE
- INDICATES SHORELINE
- INDICATES SHORELINE HINGE POINT
- INDICATES BOULDERS WITH GRADUATED SIZES
 2'φ = 10%
 3'φ = 20%
 4'φ = 40%
 5'φ = 20%
 6'φ = 10%
- INDICATES RIVER COBBLE SHELL
- INDICATES DISCHARGE RISER
- INDICATES RECIRCULATION DISCHARGE PIPE AND SIZE SEE GENERAL NOTES #2 & #3
- INDICATES RECIRCULATION INTAKE PIPE AND SIZE
- INDICATES RECIRCULATION FLOW IN GALLONS PER MINUTE @ 25PSI
- INDICATES WETLAND PLANTER
- INDICATES TOTAL EFFECTIVE WEIR LENGTH
- INDICATES TOP OF WEIR ELEVATION
- INDICATES WATER SURFACE ELEVATION
- INDICATES FINISH BOTTOM ELEVATION
- INDICATES DETAIL LETTER DESIGNATION
- INDICATES SHEET LOCATION
- FOOT INDICATES SECTION DIRECTION
- INDICATES AERATION VALVE BOX
- INDICATES 3/4" WEIGHTED AERATION TUBING
- INDICATES AREA OF INFLUENCE
- INDICATES AERATION POD

NOTE: NOT ALL SYMBOLS MAY BE USED.

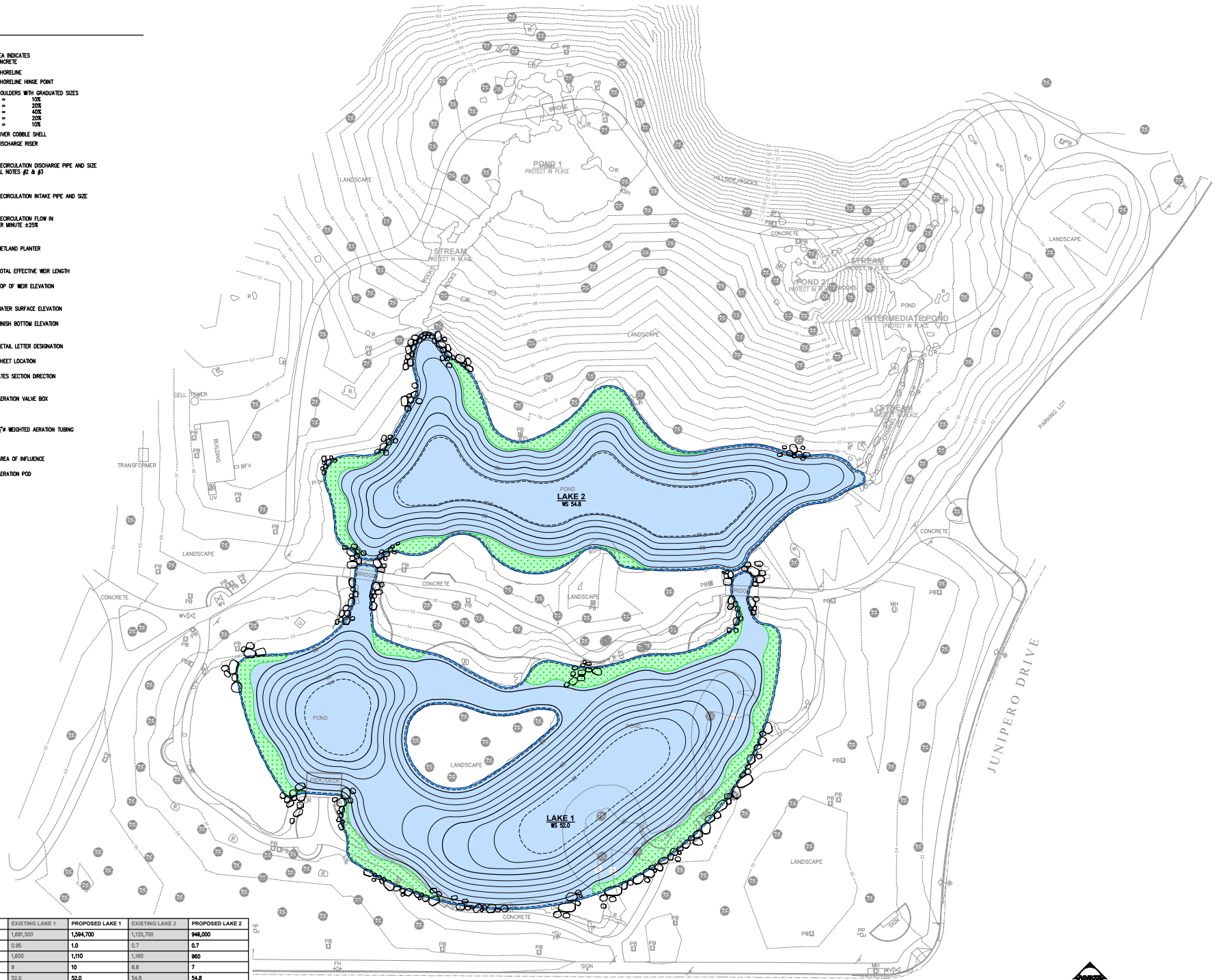

LAKE DATA

	EXISTING LAKE 1	PROPOSED LAKE 1	EXISTING LAKE 2	PROPOSED LAKE 2
VOLUME (GALLONS)	1,681,500	1,584,700	1,120,700	946,000
SURFACE AREA (ACRES)	0.95	1.0	0.7	0.7
LENGTH OF SHORELINE (FT)	1,600	1,110	1,160	960
DEPTH (FT)	9	10	8.8	7
NORMAL WATER SURFACE ELEVATION (FT)	52.0	52.0	54.8	54.8

NOTE: LAKE DATA SHOULD BE CONSIDERED AS ENGINEER'S ESTIMATE ONLY. LAKE CONTRACTOR SHOULD INDEPENDENTLY VERIFY QUANTITIES.

PLAN VIEW
1/16\"/>

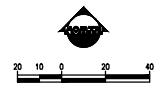

EXHIBIT 5.2 - PROPOSED LAKE GRADING - OPTION 2

May 11, 2022

5.2 Aeration





















Aeration of the lakes is provided via fine bubble diffusers at the bottom of the lakes. A blower or compressor will provide the air from the pump station to the lake diffusers. Aeration is an efficient vertical recirculation and lower power cost treatment system due to significantly smaller motor size compared to waterfall and fountain systems.

As ambient air temperatures warm, the upper layers of the lake become warmer than the ambient lake temperature. The warmed upper layers become temporarily separated from the cooler lower layers due to density differences. When this condition occurs (also called stratification), sediment and lake oxygen demands of the lower layers deplete oxygen. Providing compressed air to the bottom of the lake provides the necessary oxygen by taking the well oxygenated water (dissolved oxygen) at the surface to the bottom of the pond.

Aeration equipment includes an air compressor and air diffusers at the bottom of the pond. The compressors need to be maintained and may require rebuilding on an annual basis. The diffusers should be checked annually to make sure that there is no silt accumulation on the membrane. The diffusers are self-cleaning. However, if there is too much sediment, the surface of the diffusers may clog over time.

Since there are existing floating fountains, they can be reused as surface aerators with a similar effect as the underwater aeration. However, floating fountains will increase the water loss due to wind conditions and evaporation.

LEGEND:

-  SHADED AREA INDICATES LIMIT OF CONCRETE
-  INDICATES SHORELINE
-  INDICATES SHORELINE MINGE POINT
-  INDICATES BOULDERS WITH GRAVIMATED SIZES
 - 3/4" = 10%
 1 1/2" = 20%
 4" = 40%
 8" = 20%
 12" = 10%
-  INDICATES RIVER COBBLE SHELL
-  INDICATES DISCHARGE RISER
-  INDICATES REDCIRCULATION DISCHARGE PIPE AND SIZE SEE GENERAL NOTES #2 & #3
-  INDICATES REDCIRCULATION INTAKE PIPE AND SIZE
-  INDICATES REDCIRCULATION FLOW IN GALLONS PER MINUTE x220%
-  INDICATES WETLAND PLANTER
-  INDICATES TOTAL EFFECTIVE WEIR LENGTH
-  INDICATES TOP OF WEIR ELEVATION
-  INDICATES WATER SURFACE ELEVATION
-  INDICATES FINISH BOTTOM ELEVATION
-  INDICATES DETAIL LETTER DESIGNATION
-  INDICATES SHEET LOCATION
-  FOOT INDICATES SECTION DIRECTION
-  INDICATES AERATION VALVE BOX
-  INDICATES 3/4" WEIGHTED AERATION TUBING
-  INDICATES AREA OF INFLUENCE
-  INDICATES AERATION POD

NOTE: NOT ALL BOULDERS MAY BE USED.

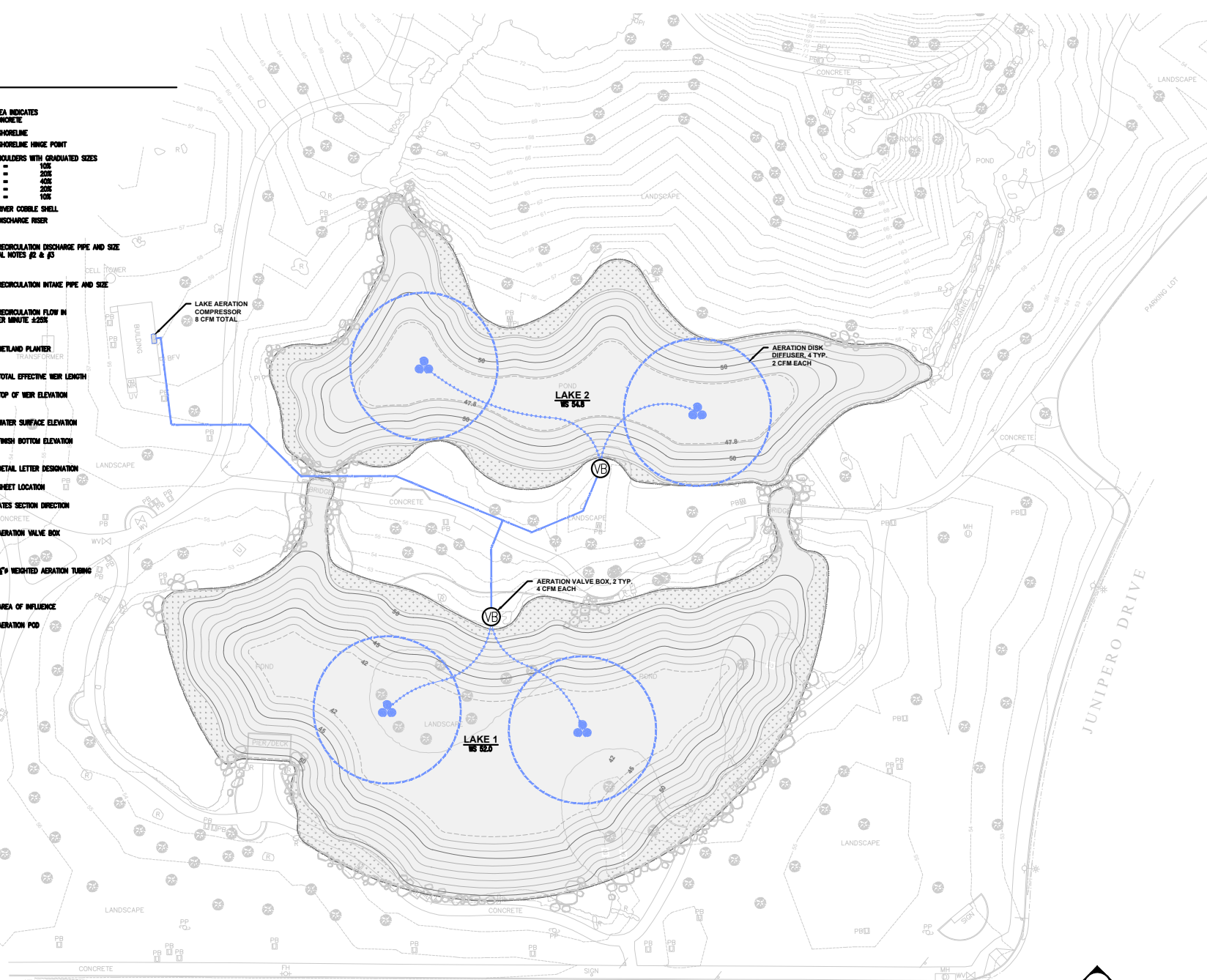

PLAN VIEW
1"=20'-0"

EXHIBIT 5.3 - LAKE AERATION SYSTEM

Apr. 15, 2022



R:\WORK\Engineering\GIS\GIS\GIS - Lake Aeration - Lake Aeration System - by me on 04/14/22 at 11:58:28 AM

5.3 Recirculation

A recirculation system enables high nutrient water (nutrient concentration increases over time) under low oxygen conditions to be mixed with oxidized water. When significant movement of water is created in a lake, regions of critical high temperature and low dissolved oxygen can be decreased. Some natural circulation occurs through wind, convection, and wave action. However, without a mechanical system, there may be areas that will not circulate properly. The equipment required for a recirculation system includes a pump and piping. Regular maintenance of the pumps will be required. Electrical components will also need to be checked on a regular basis.

There are existing pumps for pond and stream water transfers (Pump #1: 1,600 GPM), and a Lake Recirculation pump (pump #2: 2,000 GPM). PACE recommends reusing both pumps for the new lakes. Pump #1 will remain for the same function to supply water to the ponds and stream. Pump #2 has adequate flow to turn over the new lake at 1.25 days turnover for Lake 1 and 0.8 days turnover for Lake 2. The existing pumps shall be tested by the pump manufacturer, rebuild and reuse. If the pump is not reusable, a new pump can be used for lakes recirculation. The pump canisters and part of the existing piping can be reused. See Exhibit 5.4 for the proposed lakes recirculation system.

The recirculation system can serve as a dye, chemical (Alum, Chloramine) and ozone treatment delivery and mixing system. The recirculation system ensures dye, chemical and ozone can be in contact with the lake water effectively and mix well inside the lakes.

The intake pipe is also part of the recirculation system. The current bio-filter intake pipe at Lake 1 will not work due to clogging and debris buildup. PACE proposes to remove the bio-filter and use a screened intake with a fine screen (1/2" to 3/4" opening). This screen intake can be brushed and cleaned by maintenance staff. See Exhibit 5-5 for the proposed screen intake detail.

LEGEND:

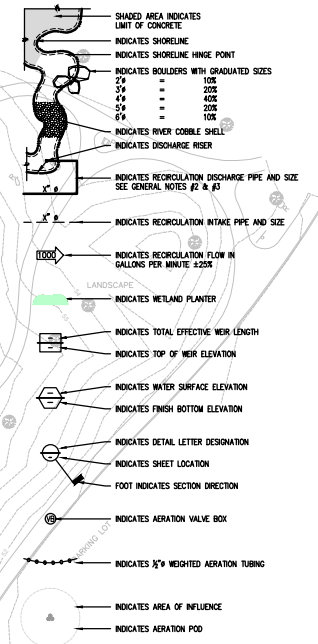

NOTE: NOT ALL SYMBOLS MAY BE USED.

LAKE DATA

	PROPOSED LAKE 1	PROPOSED LAKE 2
VOLUME (GALLONS)	2,144,100	946,000
FLOW RATE (GPM)	1,200	800
TURNOVER (DAY)	1.24	0.8

EXHIBIT 5.4 - PROPOSED LAKE RECIRCULATION SYSTEM

Apr. 15, 2022

PLAN VIEW
1"=20'-0"

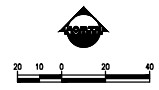

\\PAC\Engineering\Projects\2022 - Lake Recirc - Val. 2022.04 - Proposed Lake Recirculation System - by jw on 04/15/22 at 11:20:14 AM

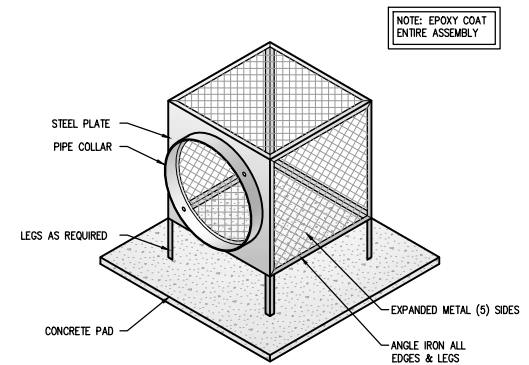
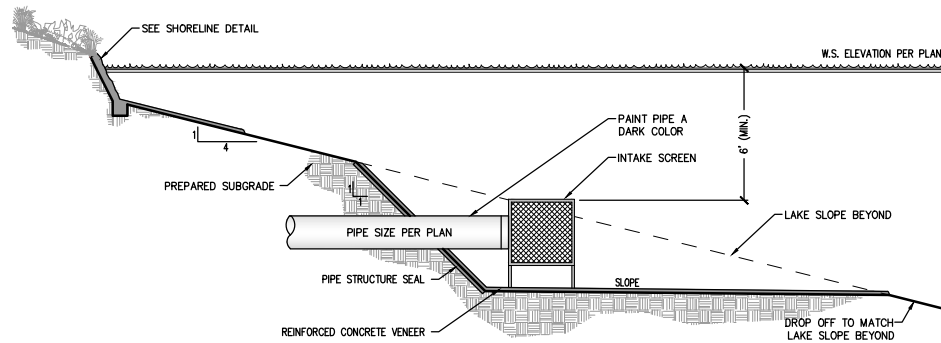
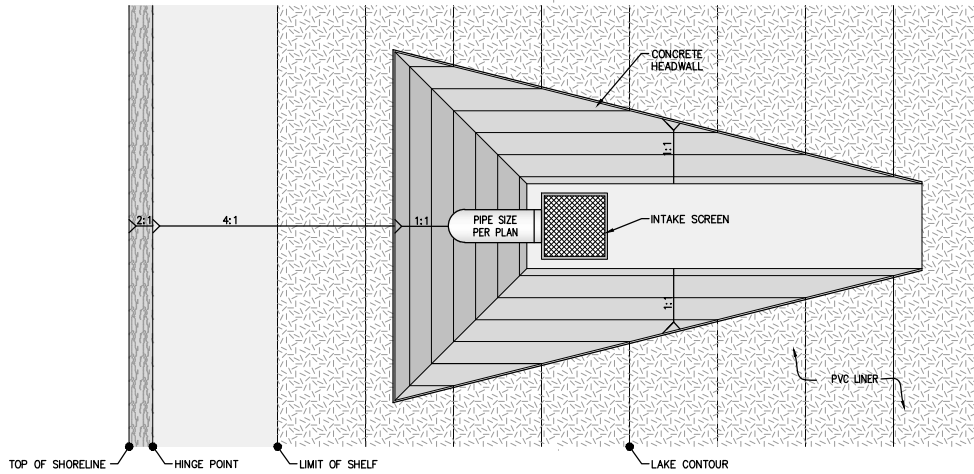

Exhibit 5.5 - Proposed Screen Intake

Apr. 15, 2022

5.4 Alum Treatment with Acid Addition

Alum or aluminum sulfate [Al₂(SO₄)₃] has been widely used in lake management to control turbidity and soluble and particulate phosphorus. By reducing the phosphorous concentration in lake water, algae production and growth are controlled. Both natural lakes and man-made lakes/reservoirs, including recycled water reservoirs, have been treated with alum, and many published reports on its short- and long-term effectiveness are available. In addition to alum, various alternative coagulants may be used, such as polyaluminum chloride (PAC) as well as more specialty products that bind with phosphorus more tightly to prevent its release. Alum and related products are widely used in water and wastewater treatment for both turbidity and phosphorus removal. Alum is non-toxic to aquatic organisms and safe to use by lake managers.

Upon its addition to water, aluminum ions (Al³⁺) react with water to form small solid particles (called floc) of amorphous aluminum hydroxide [Al(OH)₃] as shown in the equation below:

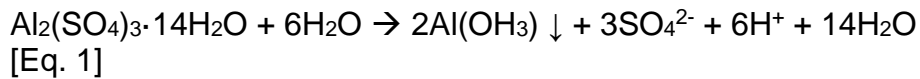

Aluminum hydroxide has a high capacity for the absorption of phosphorus. The aluminum floc precipitates (Exhibit 5-6) and forms a layer of a reactive barrier that adsorbs soluble phosphorus and prevents re-suspension of particulate phosphorus. Aluminum ions may also react with phosphate (PO₄³⁻) directly and form water insoluble aluminum phosphate (AlPO₄) that may also precipitate. The reactions between aluminum ion and phosphorous/phosphate in water are very complex and it is known that many competitive reactions occur simultaneously.

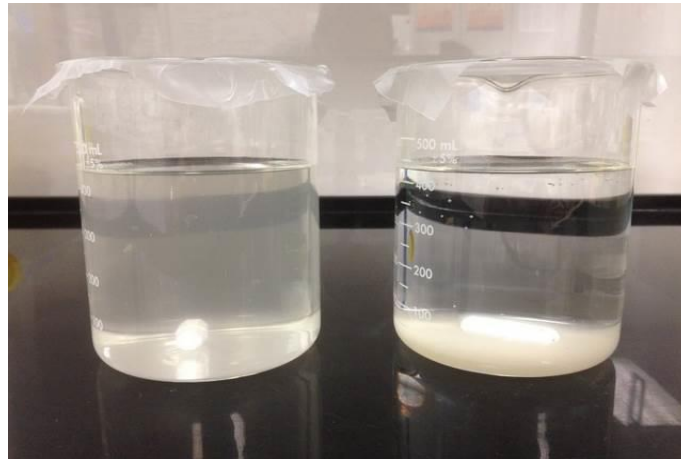

Exhibit 5-6: Alum Treatment of Turbid Water (Left: Untreated, Right: Treated)

Alum is typically added as slurry. It may be surface-applied or injected continuously or intermittently into the lake water recirculation flow. For a one-time application, 5 to 20 mg/L of alum (as Al³⁺) may be added. Alternatively, a smaller dose of alum may be added continuously. A laboratory-scale jar test may be recommended to determine the alum doses (Exhibit 5.6), especially on the reclaimed water to optimize phosphorus removal and minimize sludge generation.

A disadvantage of alum treatment is the generation and accumulation of aluminum hydroxide sludge at the bottom of the lake if allowed to settle. PACE proposes that the alum be injected into the recirculation system as described above (section 5.3). A sedimentation standpipe would be used to discharge the recirculated water with alum where sedimentation can occur in the standpipe (See Exhibit 5-7). This would facilitate the maintenance of accumulated sediment. The sediment will not be at the bottom of the lake but in these sedimentation standpipes. Alum treatment may fail when it is under-dosed because

aluminum may be bound to constituents other than phosphorus. Therefore, the dosage of alum should be carefully determined prior to its application.

To improve alum treatment, small amounts of acid shall be added to keep the pH in the corrective range for alum coagulation to process effectively.

For TeWinkle Park Lakes, the existing pump station has available space for the Alum treatment with acid addition system. PACE proposes to have a large tank (150 GAL to 200 GAL) of alum with mixer to supply enough alum for lake treatment, and a small tank (15 GAL) for acid. See Exhibit 5-8 for the proposed location of the alum treatment system.

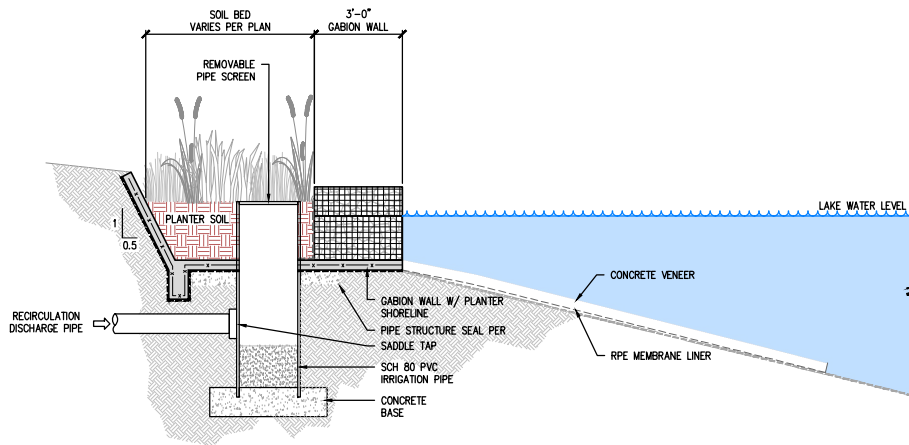

NOTE:
THIS ENTIRE ASSEMBLY SHALL BE HOT-DIP GALVANIZED AFTER ASSEMBLY.

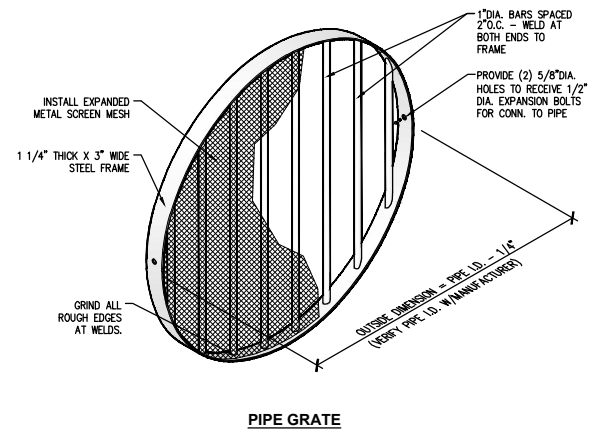
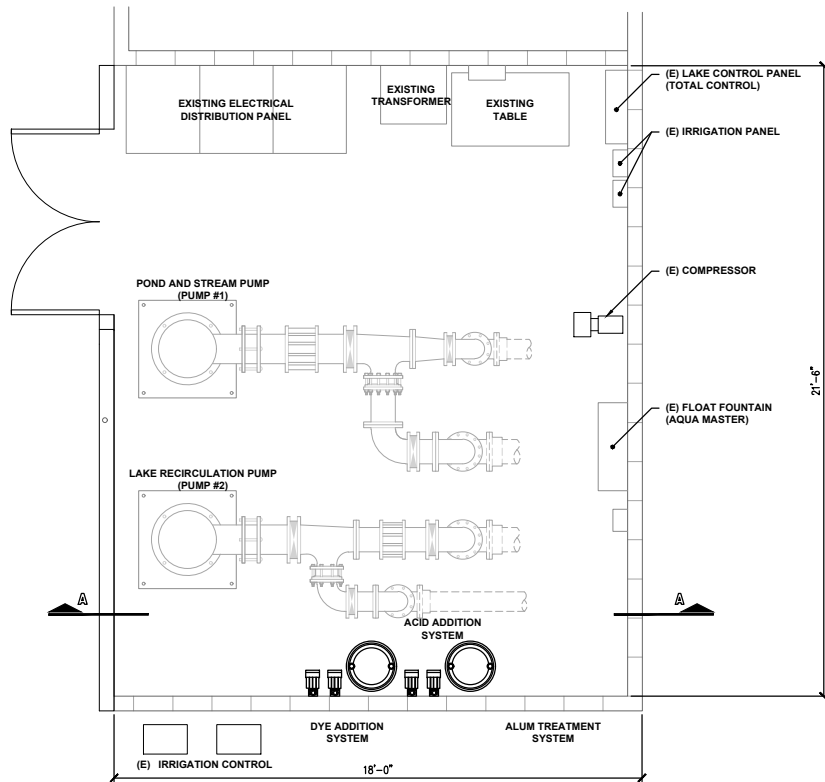

Exhibit 5.7 - Proposed Alum Discharge Standpipe inside Lake Planter

Apr. 15, 2022



17520 Newhope Street, Suite 200 | Fountain Valley, CA 92708
P: (714) 481-7300 | www.pacewater.com



PUMP STATION - PLAN VIEW
1/2"=1'-0"

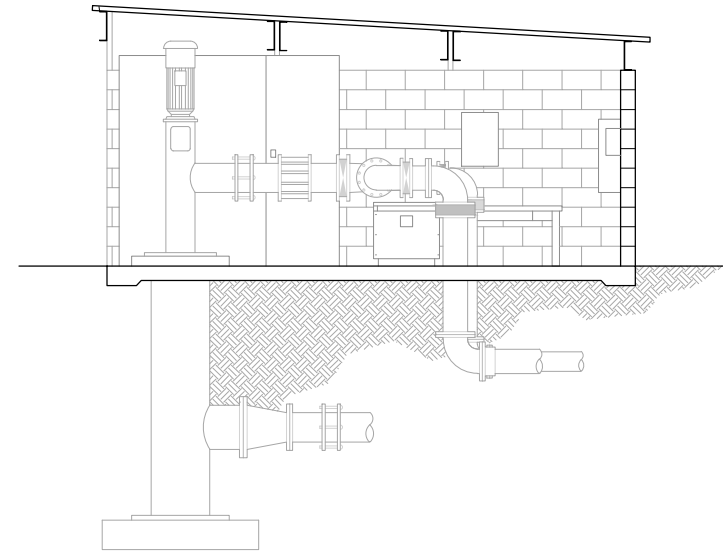

PUMP STATION - SECTION A
1/2"=1'-0"

Exhibit 5.8 - Pump Station with Alum and Acid Treatment System

Apr. 15, 2022



17520 Newhope Street, Suite 200 | Fountain Valley, CA 92708
P: (714) 481-7300 | www.pacewater.com

5.5 Treatment Planter/Wetland

In order to effectively address the large loads of nutrients, organic matter and particulates added to the pond by the abundant waterfowl and feeding of waterfowl, pollutant removal processes should be applied to the pond. These processes may include physical processes such as filtration and biological processes such as wetland treatment or media filtration.

Installation of a treatment planter/wetland at the perimeter of the lake (at strategic locations) shall be designed together with the lake recirculation discharge. The wetland would be constructed in the lakes with the water level in the wetland slightly higher than the lake. Water would be pumped to the planter/wetland and then flow by gravity through the wetland and back to the lake. A water turnover rate of approximately once per week through a treatment wetland would provide excellent water quality treatment for the lakes. See Exhibit 5.9 for the location of the lake planter/wetland.

For TeWinkle Park Lakes, the original design had no aquatic planter. PACE recommends adding an aquatic planter/wetland along the lake's shoreline with a gabion wall for this project. This shoreline design will keep the waterfowl inside the lakes and away from the walkway to improve the lake trail experience. See Exhibit 5-9 for the shoreline detail.

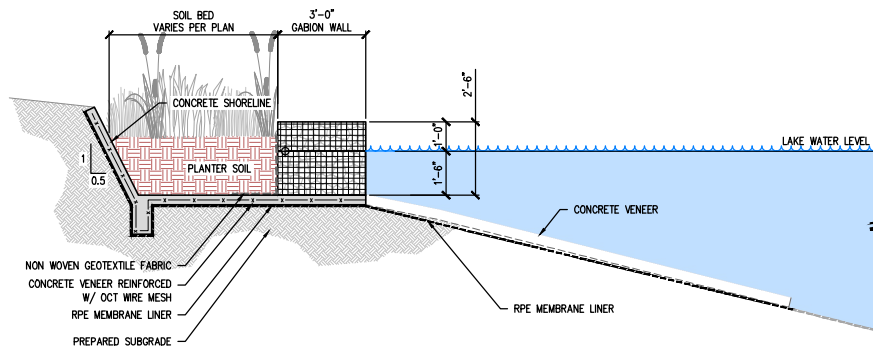

Exhibit 5.9 - Proposed Lake Planter/ Wetland Shoreline

Apr. 15, 2022



17520 Newhope Street, Suite 200 | Fountain Valley, CA 92708
P: (714) 481-7300 | www.pacewater.com

5.6 Ozone Treatment

Ozone (O_3) is a very strong oxidant and a highly effective disinfectant that has been used widely in drinking water and wastewater treatment, as well as in swimming pools, ponds, and other recreational water treatment and management. Ozone has also been used in the aquaculture industry to inactivate pathogens and oxidize organics. Ozone is a naturally occurring, water-soluble gas with three oxygen atoms, which is highly reactive in water. Ozone is very unstable and must be generated on-site from ambient air (20% oxygen) or purified oxygen (>90%) using an ozone generator (Photograph 1).

This option is significantly more expensive than other treatment options, including filtration, and alum treatment because of its higher capital and operation and maintenance costs. Ozone gas needs to be transferred to the aqueous phase (the water to be treated) using a Venturi injector (Photograph 2). In lake and reservoir water treatment and management, ozone should be injected into a side stream (e.g., recirculation flow, not directly to the lake) and then discharged to the lake to prevent ozone off-gassing from the water surface and any toxicity issues in the lake. Although ozone is extremely short-lived in natural water (last less than a few minutes), it is toxic to fish and other aquatic organisms if they are exposed to ozone directly. These requirements increase the complexity of the treatment system.



Photographs 1 and 2: Ozone Generator and Ozone Injection/Contacting System

Although the use of ozone in lakes and reservoirs is relatively rare, primarily because of its high costs and the requirement for fairly extensive maintenance, there may be benefits in using a small dosage of ozone (0.5 to 1 mg/L) in the lake recirculation water. This small dosage of ozone can:

- Improve the clarity of water
- Inactivate harmful bacteria (pathogens) and algae
- Boost the Dissolved Oxygen (DO) level (when purified oxygen was used)
- Oxidize odor-causing compounds
- Oxidize and degrade recalcitrant organics and make it more biodegradable

Any unused ozone decomposes into oxygen (O_2) and water (H_2O) and does not leave any harmful by-products.

A disadvantage of an Ozone system is the high capital and Operation and Maintenance cost. For TeWinkle Park Lakes, an isolated Ozone Room (est. 12'x12') will be required to house the ozone equipment. A separate room will help to detect any leakage, and capture and treat the ozone. The ozone system will work without an isolated room, but leakage ozone will migrate un-detected and uncontrollable. Please note that ozone is toxic to humans and harmful to the environment.

For Ozone Room Option 1, the room is added on the Westside of the existing pump station. This room is about 12' x 12' and only mounts the ozone equipment.

For Ozone Room Option 2, the room is added on the Southside of the existing pump station. This room is about 17.5' x 12'. This room will cover the ozone equipment together with irrigation control and an underground vault for water level sensors. See Exhibit 5-10 for both proposed ozone room options at Lake Pump Station.

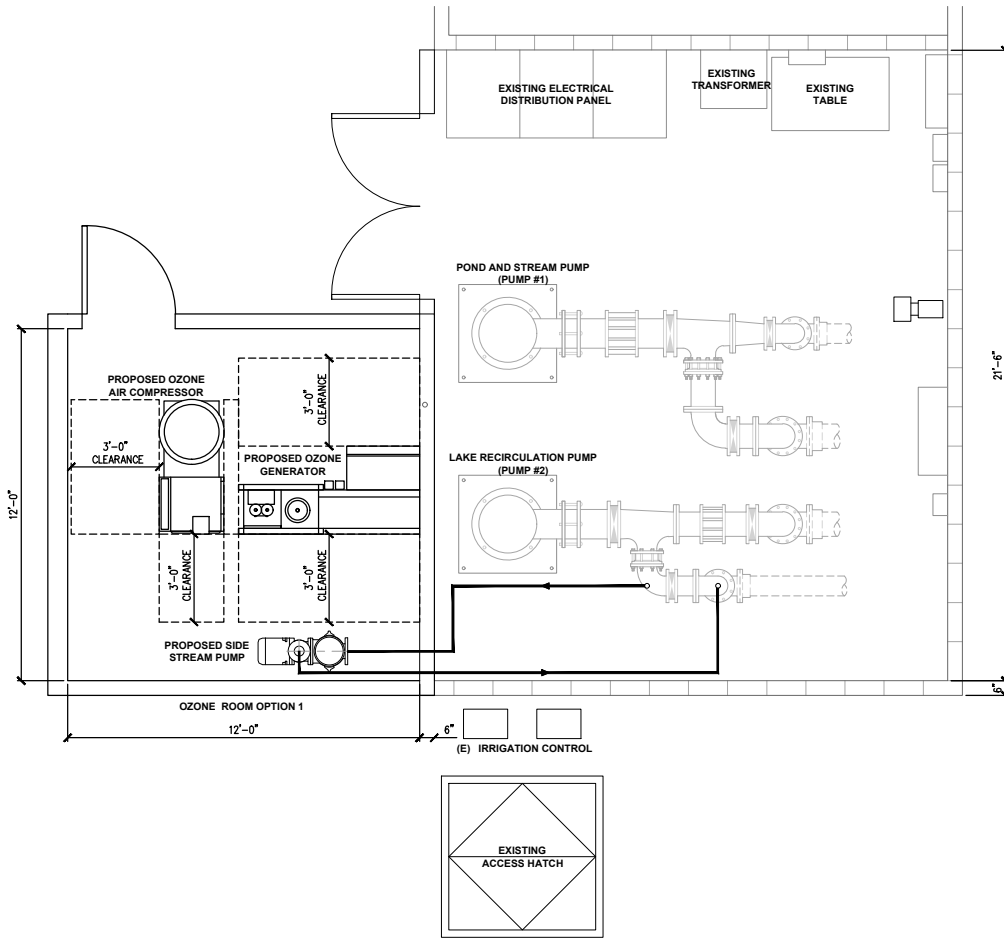

OZONE ROOM OPTION2 - PLAN VIEW
1/2"=1'-0"

Exhibit 5.10 - Pump Station with Ozone Room

Apr. 15, 2022

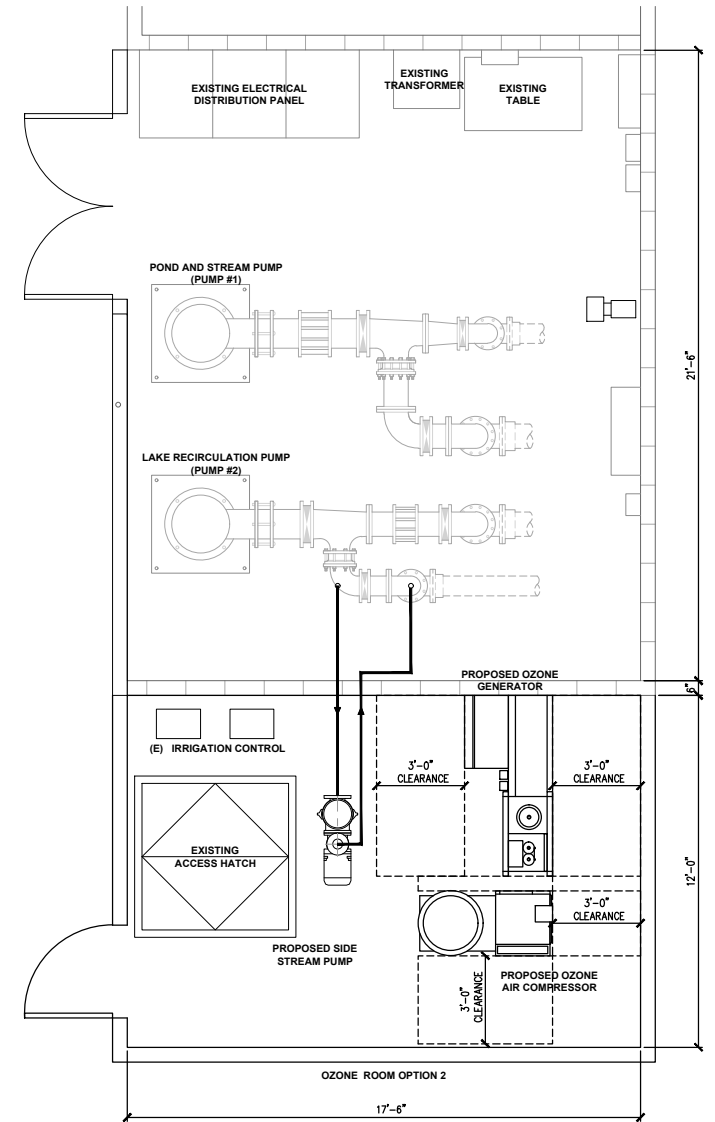

OZONE ROOM OPTION 2 - PLAN VIEW
1/2"=1'-0"



17520 Nennepo Street, Suite 200 | Fountain Valley, CA 92708
P: (714) 481-7300 | www.pacewater.com

5.7 Filtration

Particle filtration is one of the options to improve the water in the lake by removing particles up to 30 microns in size from the water. Filtration results in clear water with lower turbidity. However, it will NOT remove nutrients that are dissolved in the water that can contribute to poor water quality. A filter consists of a pressure vessel containing media (sand, zeolite, etc.) that filter out particles up to 10 microns in size. Sand filters are typically used for swimming pool applications with a turnover rate of 6 hours. For lakes, the turnover rate is not required to be 6 hours.

Filters will be blocked with debris accumulating over time within the filter vessel. Therefore, filters will need to be backwashed to clear out the debris that accumulates. The backwash water is sent typically to the sewer.

For TeWinkle Park Lakes, PACE does not recommend filtration due to the limitation of pump station space, pump pressure, sewer connection, etc. Also, the existing lake water samples do not indicate a high number of particles to make filtration a viable treatment option for this project. Instead of filtration treatment, PACE recommends the use of alum treatment to remove fine particles in the water and regularly remove sediment inside the alum discharge pipes.

5.8 Chloramine Treatment

Various common water treatment chemicals can be added to improve lake water quality. The addition of combined chlorine (chloramines) as a biocide to control algal growth is one such option. Chloramines are less potent disinfectants than free chlorine (HOCl), which is widely used as a disinfectant for drinking water and recreational water such as swimming pools. Monochloramine is significantly less toxic (i.e., median lethal concentrations are three to fourteen times higher) than free chlorine in many freshwater fish.

As noted briefly in the “Source Water (Reclaimed Water) Quality” section, chloramines are products of free chlorine [hypochlorous (HOCl) acid or hypochlorite ion (OCl⁻)] and ammonia (NH₃). First, one molecule of ammonia reacts with one molecule of hypochlorous acid to form one molecule of monochloramine (NH₂Cl) and one molecule of water:

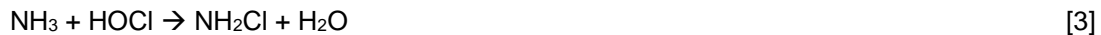

In the presence of excess free chlorine, the monochloramine further reacts with hypochlorous acid to form one molecule of dichloramine (NHCl₂) and another molecule of water:



Dichloramine may undergo several reactions to form nitrate (NO₃⁻) and nitrogen gas (N₂) where additional free chlorine is available. It should be noted that the reactions shown above are pH dependent. More dichloramine forms between pH 3 and 5 than monochloramine does, while monochloramine becomes dominant where pH is higher than 7 (Haas 1990). As a biocide/disinfectant, monochloramine is more potent than dichloramine.

Chloramine, in particular monochloramine, is widely used in the United States as a disinfectant for drinking water. In addition, chlorination/chloramination is required for the disinfection of Title 22 recycled water in California, and chloramines are often found in the raw reclaimed water that has been confirmed in our field water quality analysis as shown in the “Source Water (Reclaimed Water) Quality” section.

If properly used, monochloramine can prevent the growth of harmful and noxious algae (including cyanobacteria) in lake and pond water. PACE’s recent study with water samples from two reclaimed water lakes demonstrated that the daily addition of as low as 0.10 mg/L as Cl₂ of monochloramine could maintain the clarity of the water where the turnover time was 5 to 10 days (Photo 3). Photo 4 shows the algae that could be controlled by 0.10 mg/L of monochloramine.

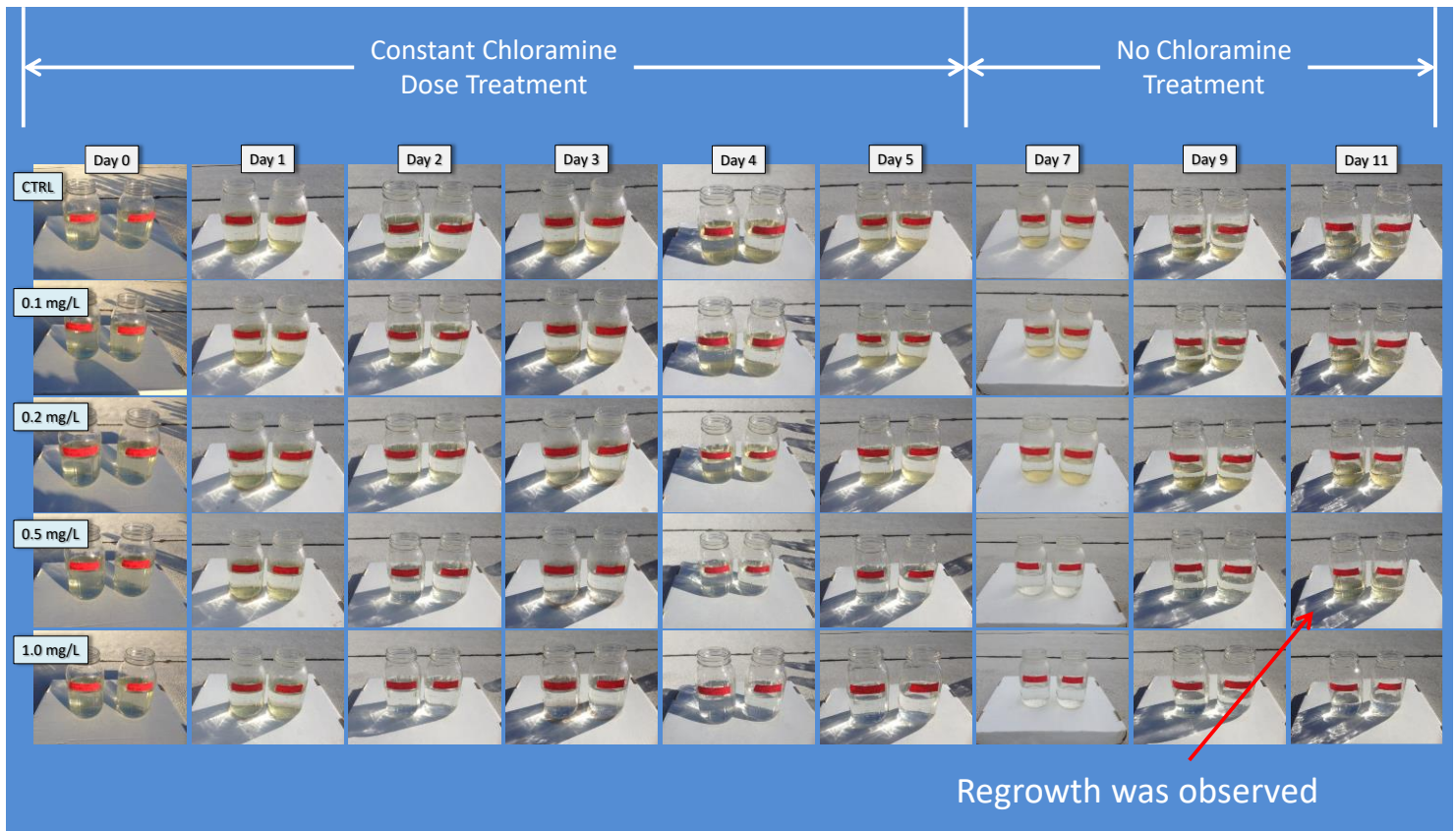

Photo 3: Impact of the Monochloramine Treatment on the Clarity of a Recycled Water Lake

Note: 1/5 of the water was withdrawn from each bottle and replenished with reclaimed water spiked with 0.1 to 1.0 mg/L of monochloramine (which corresponds to final monochloramine doses ranging from 0.02 to 0.2 mg/L) every day. Algae were pre-cultured for three days before the initiation of the chloramine treatment.



Photo 4 – Photomicrographs of Common Algae Found in Typical Reclaimed Water Lakes that can be Controlled by 0.1 mg/L of Monochloramine [Left: green algae (*Micractinium* sp.), Center: diatoms (*Melosira* sp., brown filamentous ones), Right: cyanobacteria]

There are several approaches to introduce and maintain (mono)chloramine in the Lake. It should be noted that chloramines are semi-volatile and dissipate out from the water. In addition, under sunlight exposure, chloramines decompose into ammonia and chloride ion (Cl^-) via various mechanisms. Therefore, chloramines need to be added continuously.

PACE recommends the injections of free chlorine (sodium hypochlorite solution) and ammonia (ammonium hydroxide or ammonium sulfate solution) into the lake recirculation water. The lake water may not contain a significant amount of free ammonia. In order to obtain 0.10 mg/L (as Cl_2) of monochloramine, one would need 0.03 mg/L (as N) of ammonia and 0.10 mg/L (as Cl_2) of free chlorine. Two chemical storage tanks for sodium hypochlorite solution and ammonium hydroxide solution, two metering pumps, and a control system with chlorine sensors would be needed.

One thing to note is that chloramines are known to be toxic and lethal to fish at higher concentrations (>0.2 mg/L). It is important to keep the chloramine level in the lake low (<0.1 mg/L) if the City wishes to stock fish in the lake. Having fish in the lake is not advisable as some reported chloramines may kill certain fish at a concentration as low as 0.05 mg/L (e.g., Zillich 1972), although the composition of chloramines (monochloramine, dichloramine, and nitrogen trichloride) is often unknown. It is also known that some fish species (such as Channel catfish and golden shiner) are more sensitive to chloramine toxicity than the others (such as carp); thus having these sensitive fish should be avoided. It has been reported that many fish species are fairly resistant to monochloramine toxicity if the fish are exposed to monochloramine intermittently (e.g., every 8 h).

For TeWinkle Lakes, PACE does not recommend Chloramine treatment for the lakes due to the harm to the fish and hard to control chlorine and ammonia balance in the lake. Also, the lakes have many water movement features (streams, waterfalls, and floating fountains) to keep the algae in control.

5.9 PACE Recommendations for Lake Treatment

Based on our understanding of the water quality and maintenance requirements of each proposed treatment system for the TeWinkle Park Lakes, PACE recommends that the lakes have the following systems included as part of the design:

- 5.2 Aeration
- 5.3 Recirculation
- 5.4 Alum Treatment
- 5.5 Treatment Planter/Wetland
- 5.6 Ozone Treatment

The ozone option will remove odors and color. PACE recommends ozone treatment for this project; however, the additional room, high capital cost, and heavy maintenance requirement for this system may potentially disqualify this as a feasible option.

The filtration option would definitely improve the turbidity and clarity of the water. However, the cost of the system, the maintenance required (regular backwashing), and continuous turnover of the lake water due recirculation system prevents this option from being a viable option for this project.

The Chloramine Treatment will be an ideal solution to control algae. However, this lake system has numerous water movement features and the 1.25 days turnover from the recirculation system will keep the algae down effectively.

PACE's recommendations should be reviewed by the City for consideration and future development.

6 Lake Water Balance Analysis

A preliminary water demand analysis was developed to assess the water use requirements of TeWinkle Park Lakes. The criteria utilized in the water balance analysis follow procedures and data outlined in the *California Landscape Water Management Handbook*, along with the published values of evaporation.

The precipitation and evapotranspiration data is collected from California Irrigation Management Information System (CIMIS) station #75 – Irvine. The “make-up” water to maintain the normal operating lake water level will be through the sources described in “Make-Up Source Water.” A water balance analysis was completed for the lake system that evaluated the water inputs and withdrawals. The inputs include precipitation, stormflow, and estimated nuisance flows (if applicable) while the withdrawals include only evaporation and irrigation since there will be no infiltration loss because of the lake RPE liner. Landscaping irrigation water will be withdrawn from the lake to assist in the overall lake water quality by providing the ability to replace the lake water or turnover. By evaluating the lake inputs and outputs, an evaluation of irrigation demand and lake overflow is presented herein on a monthly basis. Figure 6.1 displays a conceptual water balance schematic for TeWinkle Park Lakes used in the analysis.

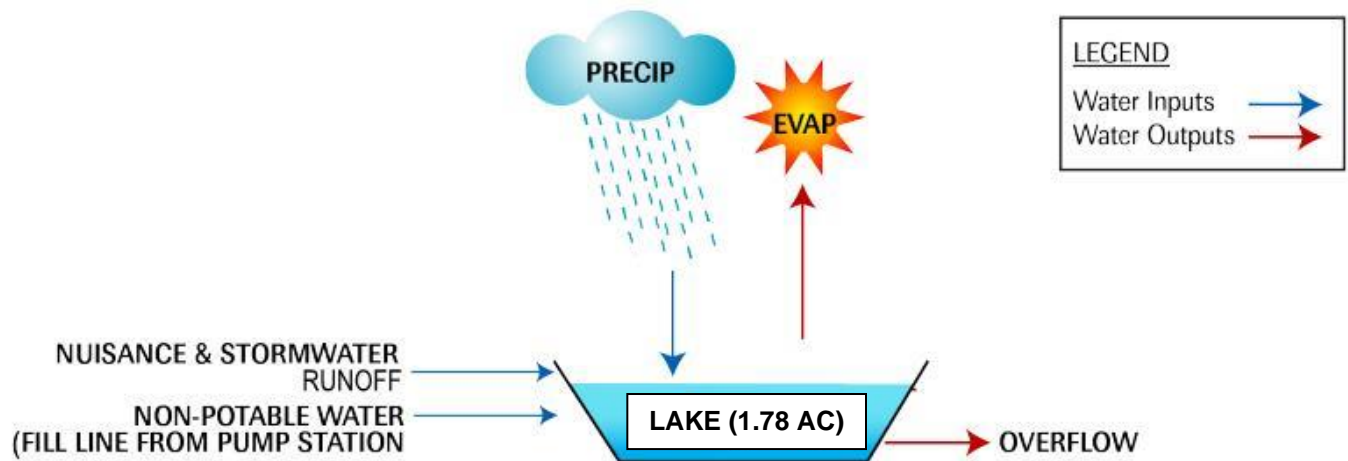

Figure 6-1: TeWinkle Park Lakes Water Balance Schematic

6.1 Methods

Calculations of lake inputs and outputs are described in the following section. A summary of the components which are included in the descriptions and in Figure 1 are listed below:

INPUTS:

- A. Direct Precipitation
- B. Storm Runoff
- C. Nuisance Runoff was not calculated in this model
- D. Make-Up Demand

OUTPUTS:

- A. Direct Evaporation
- B. Irrigation

SYSTEM INPUTS:

A. Direct Precipitation (rainfall input) is the volume of water added to the lake and convert to AC-FT (See Input column in Table 6-1). The direct precipitation was calculated using the following formula:

$$\text{Direct Precip. (AC-FT)} = \frac{\text{Lake Area (AC)} \times \text{Monthly Precipitation (inches)} \times \text{Runoff Coeff. (1.0)}}{12''}$$

With:

Lake Area (in AC): Surface Area of the Lake where rain adds water directly to the lake.

Monthly Precipitation (in inches): Average Monthly Precipitation in inches from 2012 to 2021. The data is collected by CIMIS Station #75 - Irvine.

Runoff Coefficient: for direct precipitate, the coefficient is 1.0 to show that 100% of rainfall will be added to the lake

B. Landscape Runoff is the runoff water from rainfall that was not absorb by the landscape and converted to AC-FT (See Input column in Table 6-1). The runoff areas are estimated to be the areas between the walkway to the lake shoreline.

$$\text{Landscape Runoff (AC-FT)} = \frac{\text{Landscape Area (AC)} \times \text{Monthly Precipitation (inches)} \times \text{Runoff Coeff. (0.6)}}{12''}$$

With:

Landscape Area (in AC): Landscape The runoff areas are estimated to be the areas between the walkway to the lake shoreline.

Monthly Precipitation (in inches): Average Monthly Precipitation in inches from 2012 to 2021. The data is collected by CIMIS Station #75 - Irvine.

Runoff Coefficient: for direct precipitate, the coefficient is 0.6 to show that 60% of rainfall will be added to the lake from landscape runoff.

C. Nuisance Runoff was not calculated for this analysis.

D. Make-Up Supply was estimated by calculating the difference between the total system inputs and outputs, assuming the lake has negligible storage (i.e. excess monthly INPUT will produce overflow runoff) and precipitation is distributed throughout the entire month.

SYSTEM OUTPUTS

A. The Lake Evaporation equals the monthly Evapotranspiration Rate multiplied by the area of the lakes converted to Ac-Ft. (see output column in Table 6-1). Lake Evaporation was calculated using the following formula:

$$\text{Lake Evap. (AC-FT)} = \frac{\text{Lake Area (AC)} \times \text{Evapotranspiration Rate (inches)}}{12''}$$

With:

Lake Area (in AC): Surface area of the lake where evaporation removes water directly from the lake.

Average Evapotranspiration Rate in inches from 2012 to 2021. The data is collected by CIMIS Station #75 - Irvine.

B. Floating Fountain Loss: the volume of water loss by spraying effect of the floating fountain per Section 2.2.2. Floating Fountain Loss estimated to be two times the tested condition (indoor). Assume six (6) floating fountains are 5HP model with 10 hours of operation a day (est. 170 GAL per fountain per day).

C. Irrigation demand was not calculated for this analysis.

OVERALL:

The water balance on the TeWinkle Park Lakes was calculated by taking the difference of output (direct evaporation and floating fountain loss) with total water inputs (direct precipitation and runoff) per month. During the months when the inputs to the lake were greater than the outputs, the net effect was overflow from the lakes. The months when outputs from the lake were greater than lake inputs, the system demand (make-up source water needed) was calculated.

6.2 Results and Discussion

Figure 6-2 demonstrates the anticipated lake outputs for lake evaporation and floating fountains loss per month. Figure 6.3 demonstrates the anticipated lake inputs for precipitation and landscape runoff without any nuisance runoff into the lake. Figure 6.4 shows the differential from Figures 6.2 and 6.3; this bar chart represents the net effect of all of the lake inputs and outputs. Figures 6.2, 6.3, and 6.4 are summarized in Table 6.1. The components of the water balance were calculated in Table 6.1. The tables illustrate which months there will be a demand for water, along with anticipated quantities, and which months there will be excess water from TeWinkle Park Lakes which will overflow, along with anticipated quantities.

Table 6-1: TeWinkle Park Lakes Water Balance Table

MONTH	Precipitation (in) (1)	Evaporation (in) (2)	INPUTS			OUTPUT			NET DEMANDS	
			Direct Precipitation (3) (Ac-ft)	Landscape Runoff (4) (Ac-ft)	Total Input per Month (5) (Ac-ft)	Lake Evaporation (6) (Ac-ft)	Floating Fountain Loss (7) (Ac-ft)	Total Output per Month (8) (Ac-ft)	Lake Demand (9) (Ac-ft)	Overflow per Month (10) (Ac-ft)
JAN.	1.60	2.02	0.26	0.38	0.63	0.32	0.06	0.39	0.00	0.31
FEB.	1.23	2.42	0.20	0.29	0.49	0.39	0.06	0.45	0.00	0.10
MARCH	1.00	3.42	0.16	0.24	0.40	0.55	0.06	0.61	0.21	0.00
APRIL	0.61	4.18	0.10	0.14	0.24	0.67	0.06	0.73	0.49	0.00
MAY	0.33	4.40	0.05	0.08	0.13	0.71	0.06	0.77	0.64	0.00
JUNE	0.07	4.95	0.01	0.02	0.03	0.80	0.06	0.86	0.83	0.00
JULY	0.09	5.52	0.01	0.02	0.04	0.89	0.06	0.95	0.91	0.00
AUGUST	0.06	5.41	0.01	0.01	0.02	0.87	0.06	0.93	0.91	0.00
SEPT.	0.24	4.22	0.04	0.06	0.10	0.68	0.06	0.74	0.64	0.00
OCT.	0.40	3.33	0.06	0.09	0.16	0.54	0.06	0.60	0.44	0.00
NOV.	0.74	2.32	0.12	0.17	0.29	0.37	0.06	0.43	0.14	0.00
DEC.	1.87	1.79	0.30	0.44	0.74	0.29	0.06	0.35	0.00	0.45
SUM	8.24	43.98	1.32	1.94	3.26	7.07	0.73	7.80	5.21	0.86

		Direct Precipitation (3) (Ac-ft)	Landscape Runoff (4) (Ac-ft)	Total Input per Month (5) (Ac-ft)	Lake Evaporation (6) (Ac-ft)	Floating Fountain Loss (7) (Ac-ft)	Total Output per Month (8) (Ac-ft)	Lake Demand (9) (Ac-ft)	Overflow per Month (10) (Ac-ft)
Runoff Coefficient		1	0.6	n/a	n/a	n/a	n/a	n/a	n/a
Irrigation Efficiency		n/a	-	n/a	n/a	n/a	n/a	n/a	n/a
Plant Factor		n/a	-	n/a	n/a	n/a	n/a	n/a	n/a
Area (Ac)		1,928	4.7	n/a	1,928	n/a	n/a	n/a	n/a

Notes:

- (1) Average Monthly Precipitation in inches from 2012 to 2021. The data is collected by CIMIS Station #75 - Irvine.
- (2) Average Evapotranspiration Rate in inches from 2012 to 2021. The data is collected by CIMIS Station #75 - Irvine.
- (3) Direct Precipitation equals the area of the lakes multiplied by Precipitation (1).
- (4) Landscape runoff = Landscape area x Runoff coefficient and convert to Ac-Ft. Assume Runoff coefficient of 0.6
- (5) Total Input per month equals the sum of (3), and (4)
- (6) Lake Evaporation equals the monthly Evapotranspiration Rate (2) multiplied by the area of the lakes and convert to Ac-Ft.
- (7) Floating Fountain Loss estimated to be 2 time of the tested condition (indoor). Assume (6) floating fountains are 5HP model with 10 hours of operation a day (est. 170 GAL per fountain per day)
- (8) Total Output per month equals sum of (6) and (7).
- (9) Lake Demand is the difference in Lake Inputs (5) and Outputs (8), equal to zero if Inputs exceed Outputs.
- (10) Sum of the total input per month (5) minus the total output per month (8). If the total output (8) is greater than the input (5), the cell reads zero, if not the total input - total output is entered.

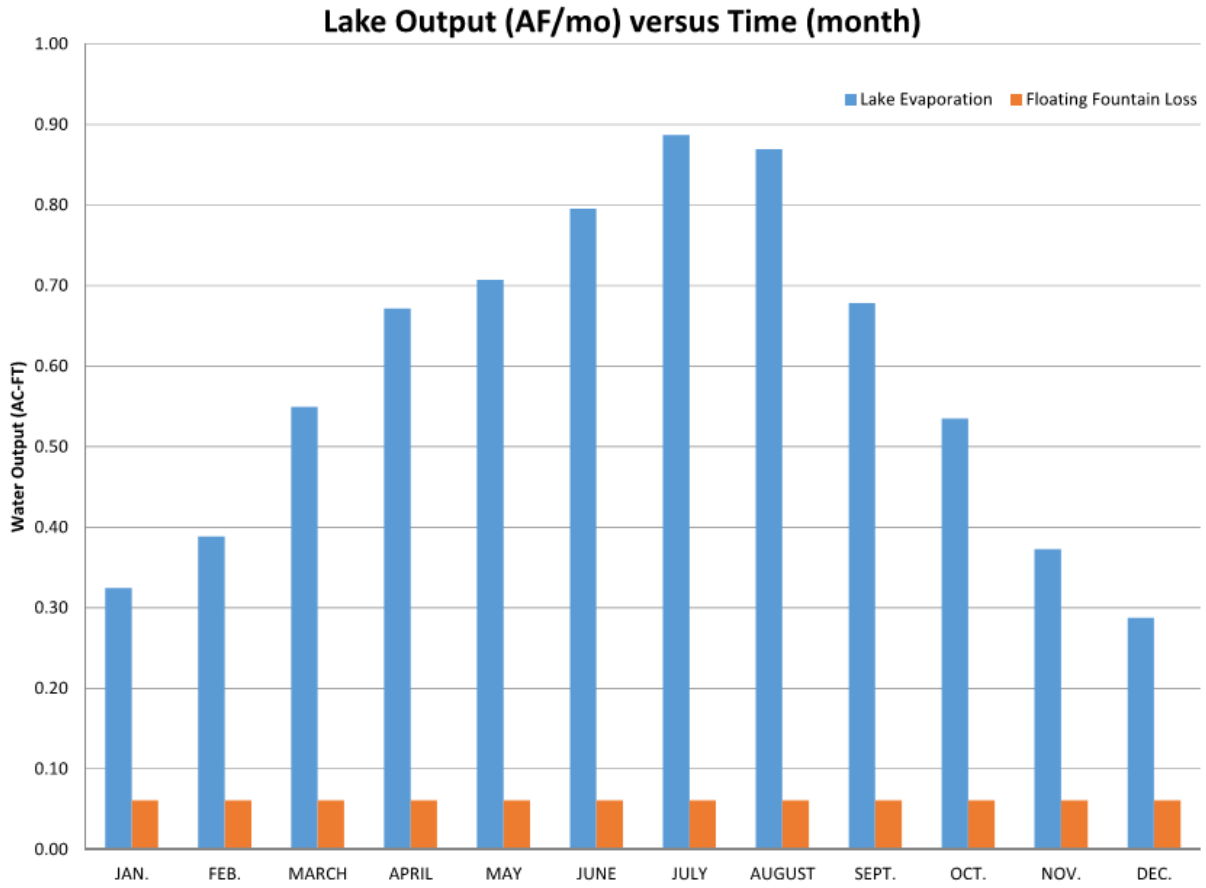

Figure 6-2: Lakes Monthly Output

Lake Input (AF/mo) versus Time (mo)

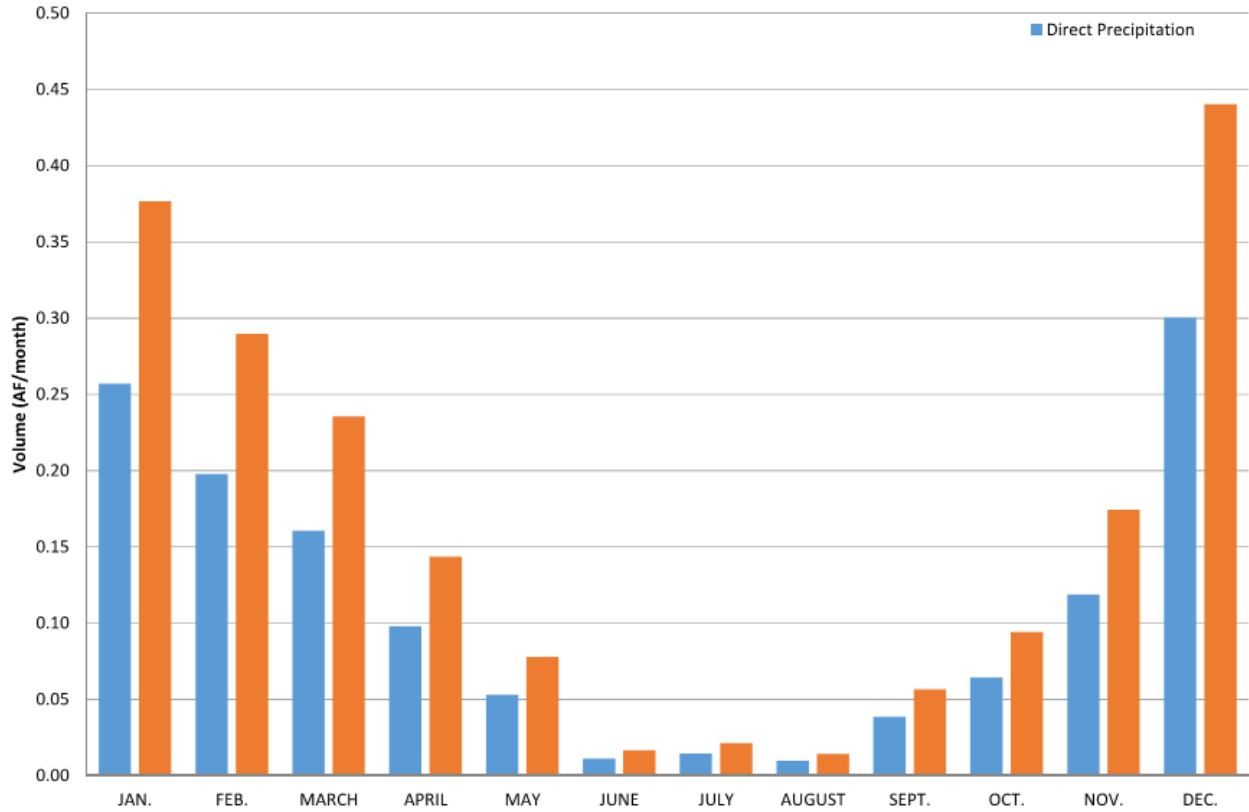

Figure 6-3: Lakes Monthly Input

Net Demand (AF/mo) versus Time (mo)

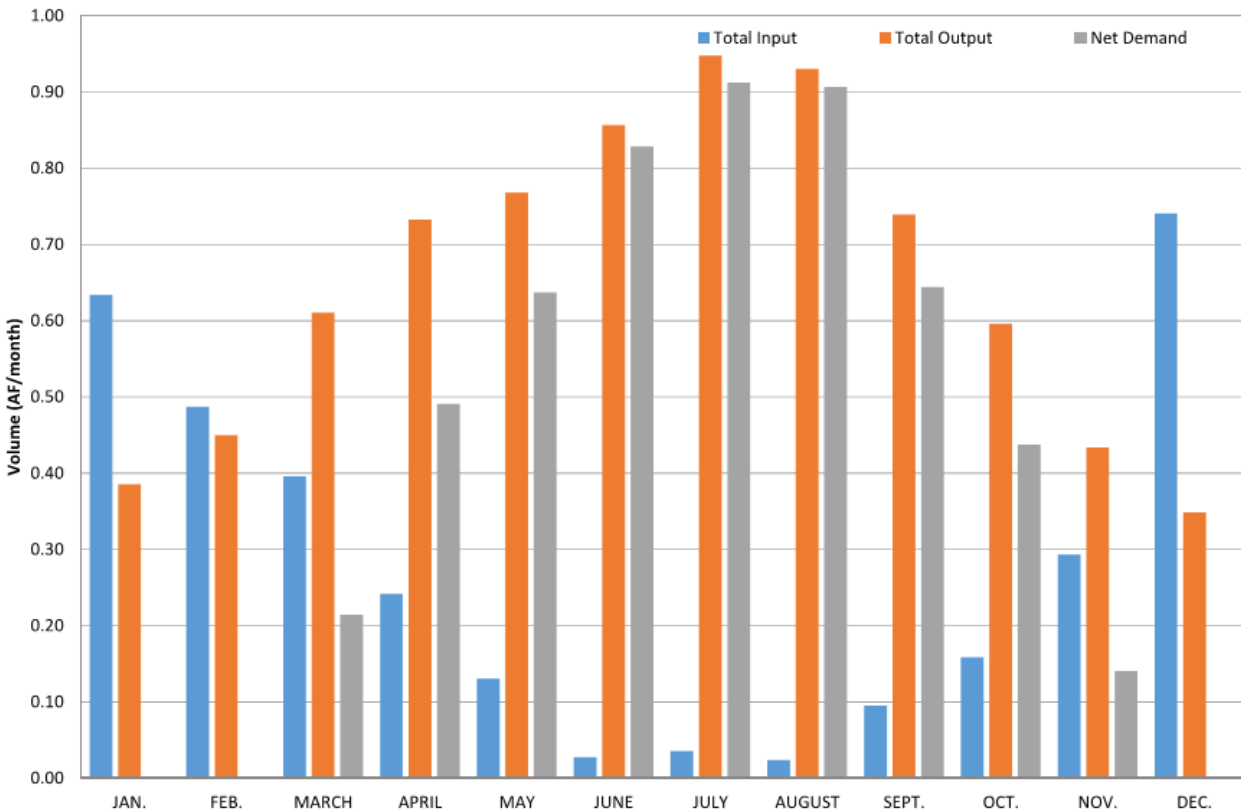

Figure 6-4: Lakes Water Monthly Demand

6.3 Usage Record and Leakage

PACE reviewed the record water usage of the lakes. The data from 2013 and 2017 does not reflect a standard water use record will missing units in the years 2013, 2015, and 2016 and inconsistency on the record for the years 2014 and 2017. PACE will not use the water usage record for the analysis of this project.

PACE is using the precipitation and evapotranspiration data collected from California Irrigation Management Information System (CIMIS) station #75 – Irvine from 2012 to 2021 to use estimate the water demand and water loss of the lake.

As discussed in Section 2.2.3 – Lake, Pond and Stream Liner and Shoreline, the pond has numerous evidences of leakage and losing water through the liner and shoreline punctures. PACE engineer concludes that the lakes are leaking.

6.4 Water Balance Conclusion

Based on the results displayed in Table 6.1 and Figure 6.2, July is the peak make-up water demand month. Roughly 220 GPM of makeup water is required, for a total of 0.97 AF/mo in July, assuming daily pumping at a duration of 24-hours per day.

The total anticipated make-up water demand for the entire year based on Table 6.1 (without nuisance flow) is approximately 5.73 AF/yr.

6.5 Make-up Source Waters

The main fill source for TeWinkle Park Lakes is from potable water provided by the City. Potable water is a high-quality water source which will increase the water quality of the lake. However, the potable water is expensive to fill the lake for a long period of time, especially during drought conditions.

A secondary source of make-up water can be a reclaimed water line. In the event that the potable water supply is not available for use for whatever reason, reclaimed water will be available to make up water that is lost through evaporation. Reclaimed water is an inexpensive lake fill option that many lakes in the area use during drought conditions. Although the reclaimed water quality is not as good as potable water, the lake treatments system (Section 5) will maintain the water quality of the lake. If this source is used as a primary fill, a water quality analysis shall be provided to PACE for review and design of the lake system. Please note that the reclaimed usage for lake fill will require a permit from the City.